

Gebrauchsanleitung PK-Nr. 3612

Instructions / Mode d'emploi / Gebruiksaanwijzing /
инструкция по использованию / 使用说明 / Használati utasítás

YUNY by
PAIDI

PAIDI Möbel GmbH - Hauptstraße 87
97840 Hafnlohr - Germany - info@paidi.de

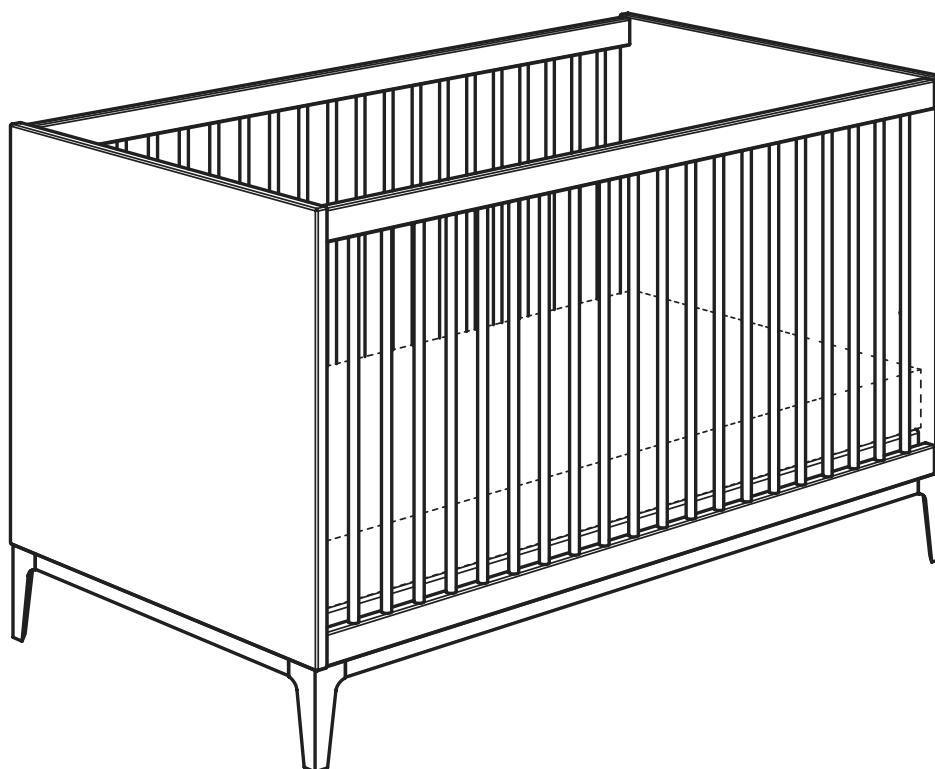

CUTIE LEA
176 5781



Warnhinweis!

Warning! / Avertissement! / Waarschuwing! / Предупреждение! / 警告! / Figyelmeztetés



YUNY by PAIDI

PAIDI Möbel GmbH - Hauptstraße 87
97840 Hafnlohr - Germany - info@paidi.de

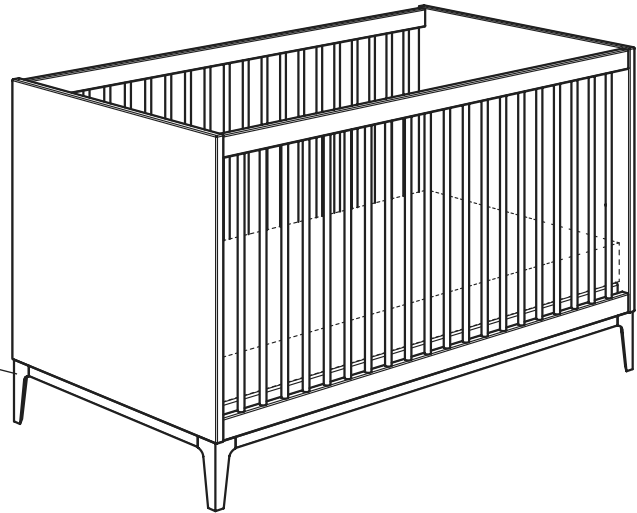
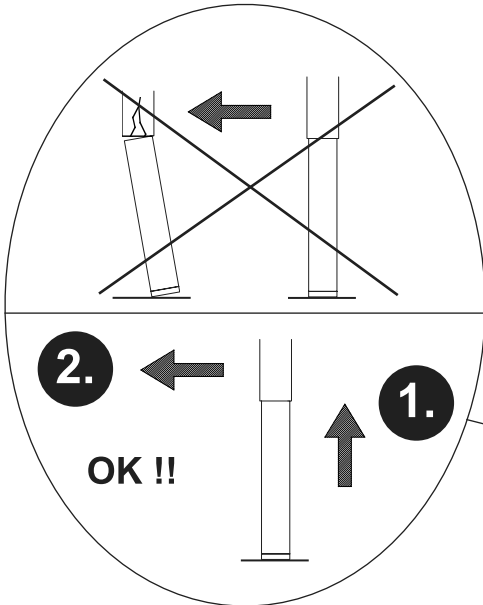
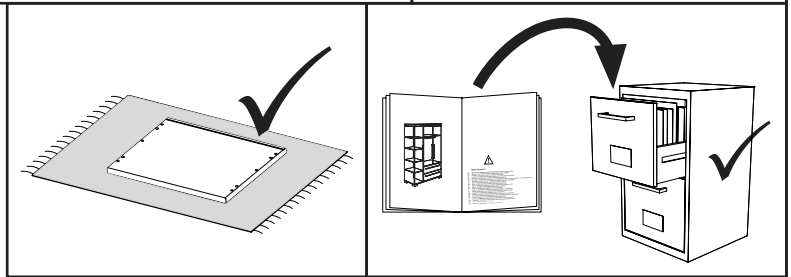

- DE Schraubenverbindungen von Zeit zu Zeit auf ihre Festigkeit prüfen, gegebenenfalls nachziehen, da die Stabilität der Konstruktion sonst nicht gegeben ist.**
- FR** Vérifier les connexions à vis de temps en temps, resserrer celles-ci le cas échéant, car, sinon, la stabilité de la construction ne serait pas assurée.
- GB** Check the tightness of the screw connections from time to time and tighten if necessary, as otherwise the stability of the construction is not assured.
- NL** Schroefverbindingen moeten van tijd tot tijd op hun stevigheid worden gecontroleerd en eventueel worden vastgedraaid, aangezien de stabiliteit van de constructie anders niet verzekerd is.
- ES** Compruebe de vez en cuando la firmeza de las uniones atornilladas y reapriete los tornillos si fuera necesario, pues de lo contrario quedaría afectada la estabilidad de la estructura.
- GR** Πού και πού ελέγχετε τη σταθερότητα των κοχλιωτών συνδέσεων κι εφ' όσον είναι ανάγκη, τις σφίγγετε ξανά, επειδή διαφορετικά δεν είναι η ευστάθεια της κατασκευής δεδομένη.
- IT** Controllare di tanto in tanto la tenuta delle connessioni a viti, all'occorrenza provvedere a serrarle di nuovo, poiché altrimenti non è garantita la stabilità della struttura.
- CZ** Čas od času zkontrolujte pevnost šroubových spojů, případně je dotáhněte, jinak nebude konstrukce stabilní.
- SL** Vijačne zveze od časa do časa preveriti glede na trdnost, po potrebi priviti, saj sicer stabilnost konstrukcije ne bo zagotovljena.
- PL** Połączenia śrubami sprawdzać od czasu do czasu pod kątem ich trwałości, ewentualnie dokręcać, gdyż inaczej konstrukcja nie jest stabilna.
- BG** Контролирайте от време на време дали болтовите съединения са добре завинтени, тъй като в противен случай не може да се гарантира стабилността на конструкцията.
- HR** Spojve vijaka s vremena na vrijeme provjeriti u svezi čvrstoće, po potrebi stegnuti, jer inače nije zajamčena stabilnost konstrukcije.
- LT** Kartais patikrinkite varžtų jungčių stiprumą, prireikus suvėžkite juos stipriau, nes priešingu atveju konstrukcija nebus stabil.
- RU** Перепроверяйте время от времени болтовые соединения. Они должны быть плотно затянуты. Это гарантирует стабильность конструкции.
- CN** 请经常的检查连接处的螺丝，如有发现松动请及时锁紧，否则将无法保障其稳定性。
- HU** Időről ellenőrizze a csavarkötések szorosságát, adott esetben a csavarokat után kell húzni, ellenkező esetben a szerkezet stabilitása nem adott.
- DE Pflegehinweis: Zum Reinigen der Oberflächen ein leicht-feuchtes Tuch oder ein handelsübliches Möbelpflegemittel verwenden.**
- FR** Indication sur l'entretien: pour nettoyer les surfaces, utiliser un chiffon légèrement humide ou un nettoyeur pour meubles en vente dans le commerce
- GB** Caring for the...: In order to clean the surfaces please use a slightly damp cloth or commercially available furniture care product.
- NL** Verzorgingsanwijzing: Voor het reinigen van de oppervlakken een licht vochtig doek of een gebruikelijk meubelschoonmaakmiddel gebruiken.
- ES** Recomendaciones de cuidado: Para limpiar las superficies del mueble debe usar un trapo humedecido o un producto de limpieza de muebles comercial.
- GR** Οδηγίες περιποίησης: Για το καθάρισμα των επιφανειών να χρησιμοποιείτε ένα ελαφρά νοτισμένο πανάκι ή λούστρο επίπλων.
- IT** Indicazione per pulizia e cura: Per la pulizia delle superfici utilizzate un panno leggermente umido o un normale prodotto per la cura dei mobili.
- CZ** Pokyny k čištění: Na čištění povrchu použijte pouze navlhčený kousek látky nebo běžný prostředek na ošetřování nábytku.
- SL** Navodilo za nego: Za čiščenje površin uporabljajte malo vlažno sunjo ali trgovsko običajno sredstvo za nego pohištva.
- PL** Wskazówka pielęgnacyjna: do czyszczenia powierzchni stosować lekko wilgotną ściereczkę lub zwykły środek do pielęgnacji mebli.
- BG** Указание за поддържане: Използвайте леко навлажнена кърпа или обикновен препарат за поддържане на мебели, за да почистите повърхностите.
- HR** Upute za njegu: Za čišćenje površina upotrijebiti jednu lako navlaženu krpu i trgovačko uobičajeno sredstvo za njegu namještaja.
- LT** Rekomendacija priežiūrai: Paviršius valykite drėgna pašluoste arba parduotuvėse įsigytomis baldų priežiūros priemonėmis.
- RU** Рекомендации по уходу: для очистки поверхностей используйте слегка влажную тряпку или обычное средство по уходу за мебелью.
- CN** 保养说明: 清洁表面只需用稍微潮湿的布或普通的家具清洁剂即可。
- HU** Ápolás: A felületek tisztításához enyhén nedves ruhát vagy a kereskedelemben kapható bútórúpoló terméket használjon.
- AR** إرشاد للعناية: يرجى من أجل تنظيف الأسطح استخدام منديل رطب بعض الشيء أو استخدام إحدى مواد تنظيف الأثاث المتوفرة في الأسواق التجارية.

Beschläge

Fittings / Raccords / Hulpstukken /
Фурнитура / 配件 / Vasalatok

YUNY by PAIDI

PAIDI Möbel GmbH - Hauptstraße 87
97840 Hafnlohr - Germany - info@paidi.de

1:1
DIN A4





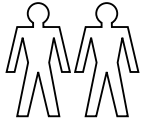



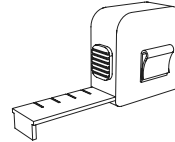

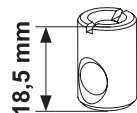
ca. 1,0h

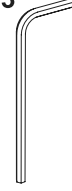
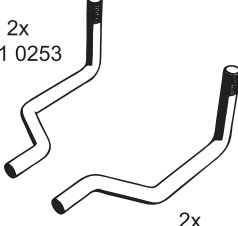

PZ 2

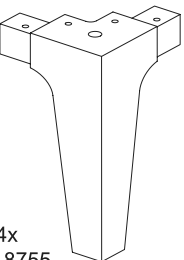
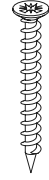

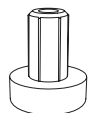
<p>B</p>  <p>8x 681 0775</p>	<p>C</p>  <p>18,5 mm 8x 681 0773</p>	<p>D2</p>  <p>8x 681 0784</p>	<p>D3</p>  <p>SW3 1x 681 3009</p>	<p>E</p>  <p>2x 681 0253 2x 681 0254</p>	<p>F</p>  <p>4x 681 2047</p>	<p>Q</p>  <p>SW4 1x 681 3011</p>	<p>Y</p>  <p>4x 681 8863</p>
<p>H1</p>  <p>4x 681 8755</p>	<p>H2</p> <p>Sockelprofil Länge: 1310mm</p> <p>2x 681 8756</p>	<p>H3</p> <p>Sockelprofil Länge: 626mm</p> <p>2x 681 8762</p>	<p>I</p>  <p>4,0 x 40 8x 681 4907</p>	<p>J</p>  <p>4 x 13 6x 681 4927</p>	<p>K</p>  <p>4x 681 1184</p>		

V1

Vorbereitung / Preparation /
Préparation / Voorbereiding /
Подготовка / 准备 / Előkészítés

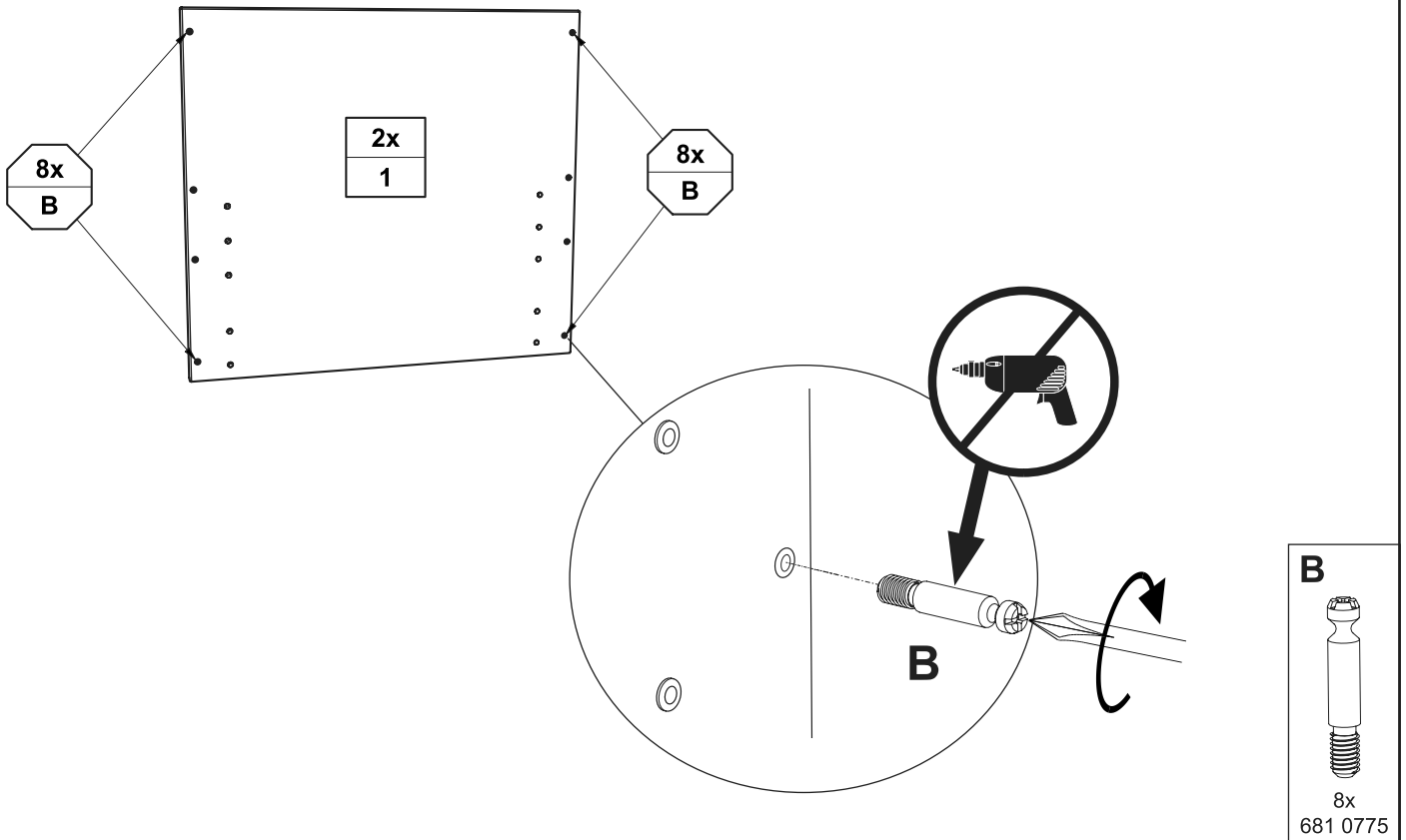

V2

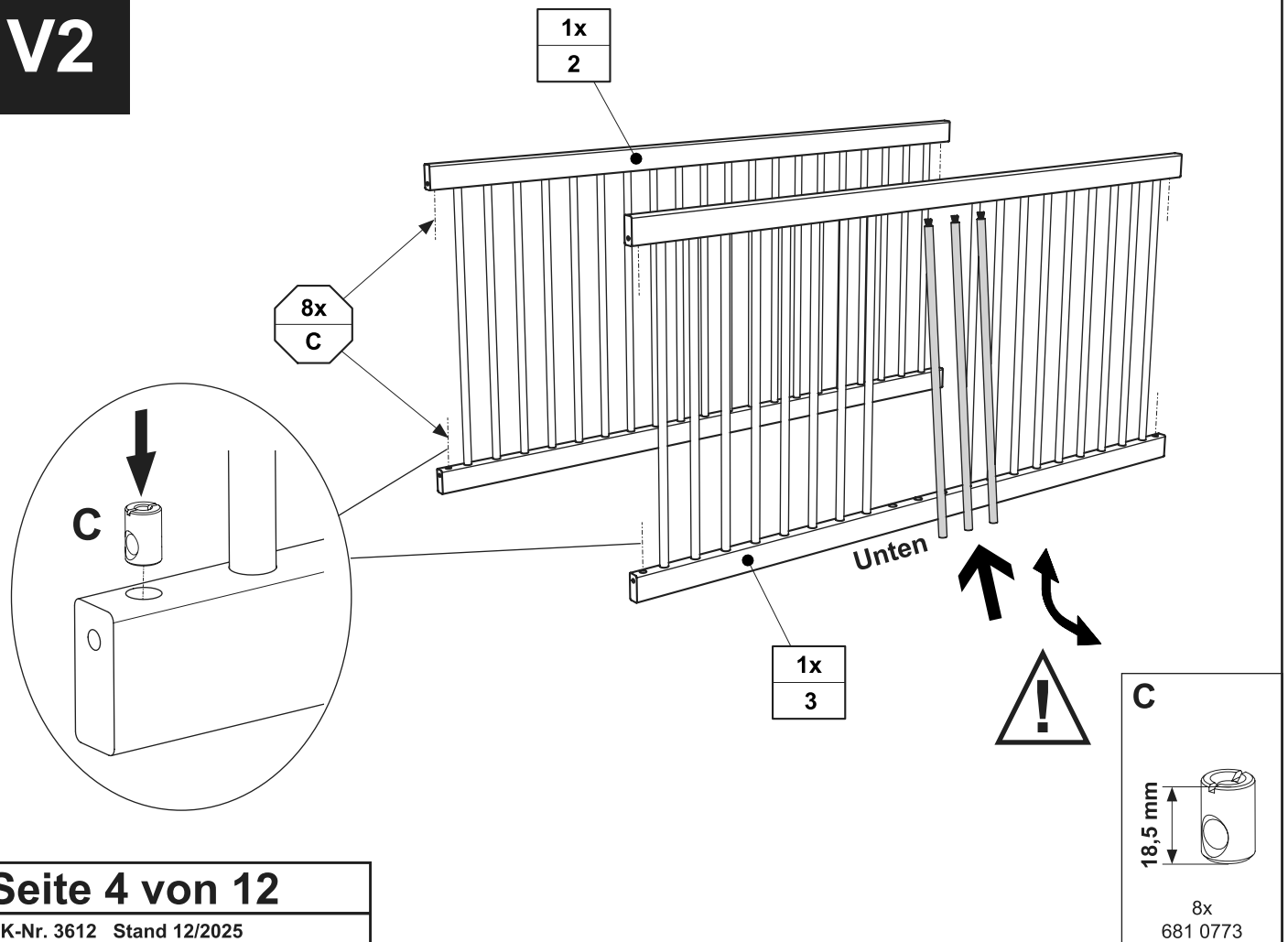

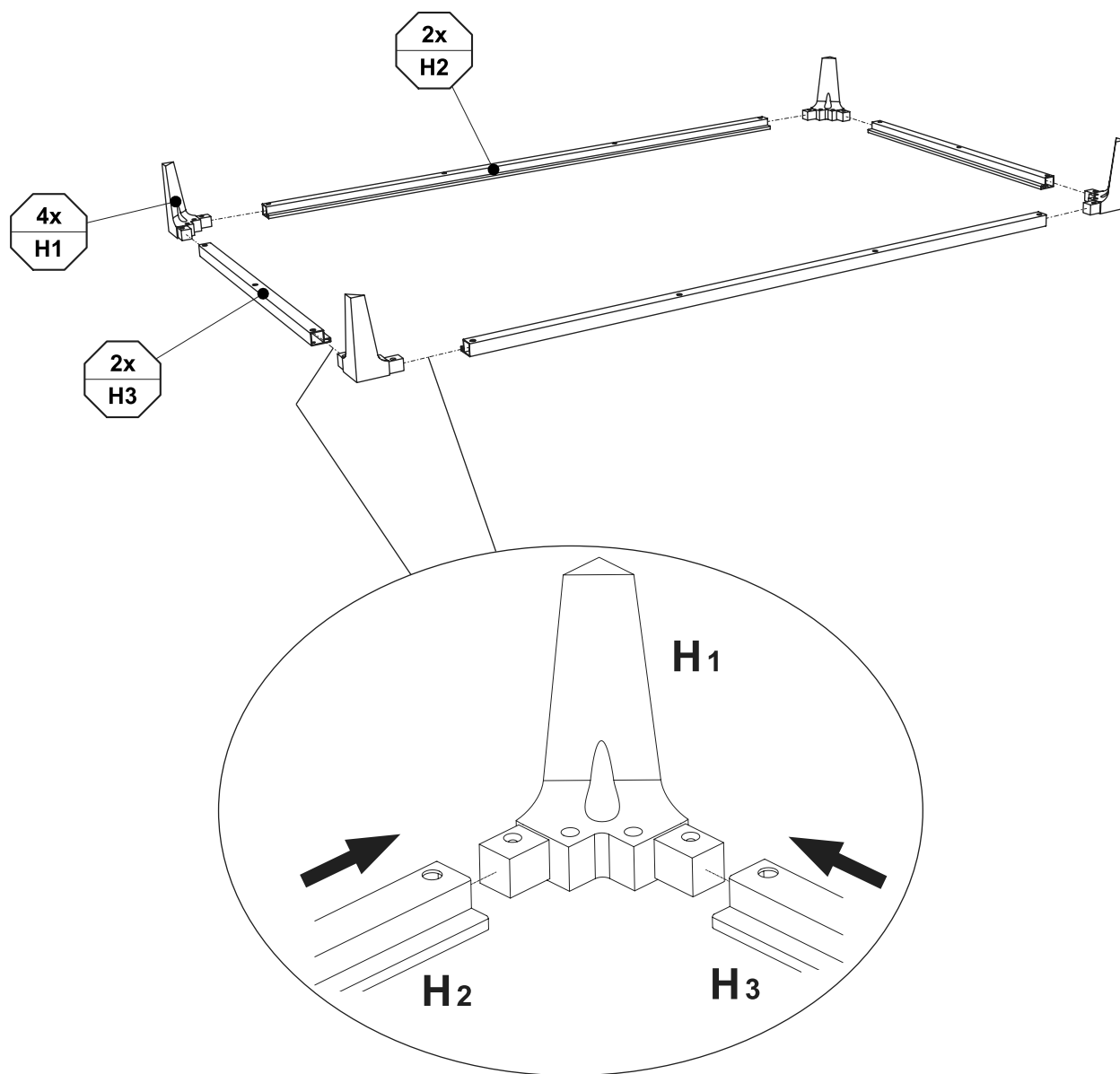

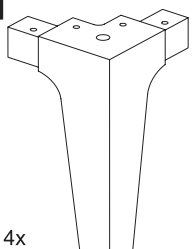

<p>H1</p>  <p>4x 681 8755</p>	<p>H2</p> <p>Sockelprofil</p> <p>Länge: 1310mm</p> <p>2x 681 8756</p>	<p>H3</p> <p>Sockelprofil</p> <p>Länge: 626mm</p> <p>2x 681 8762</p>
---	---	--

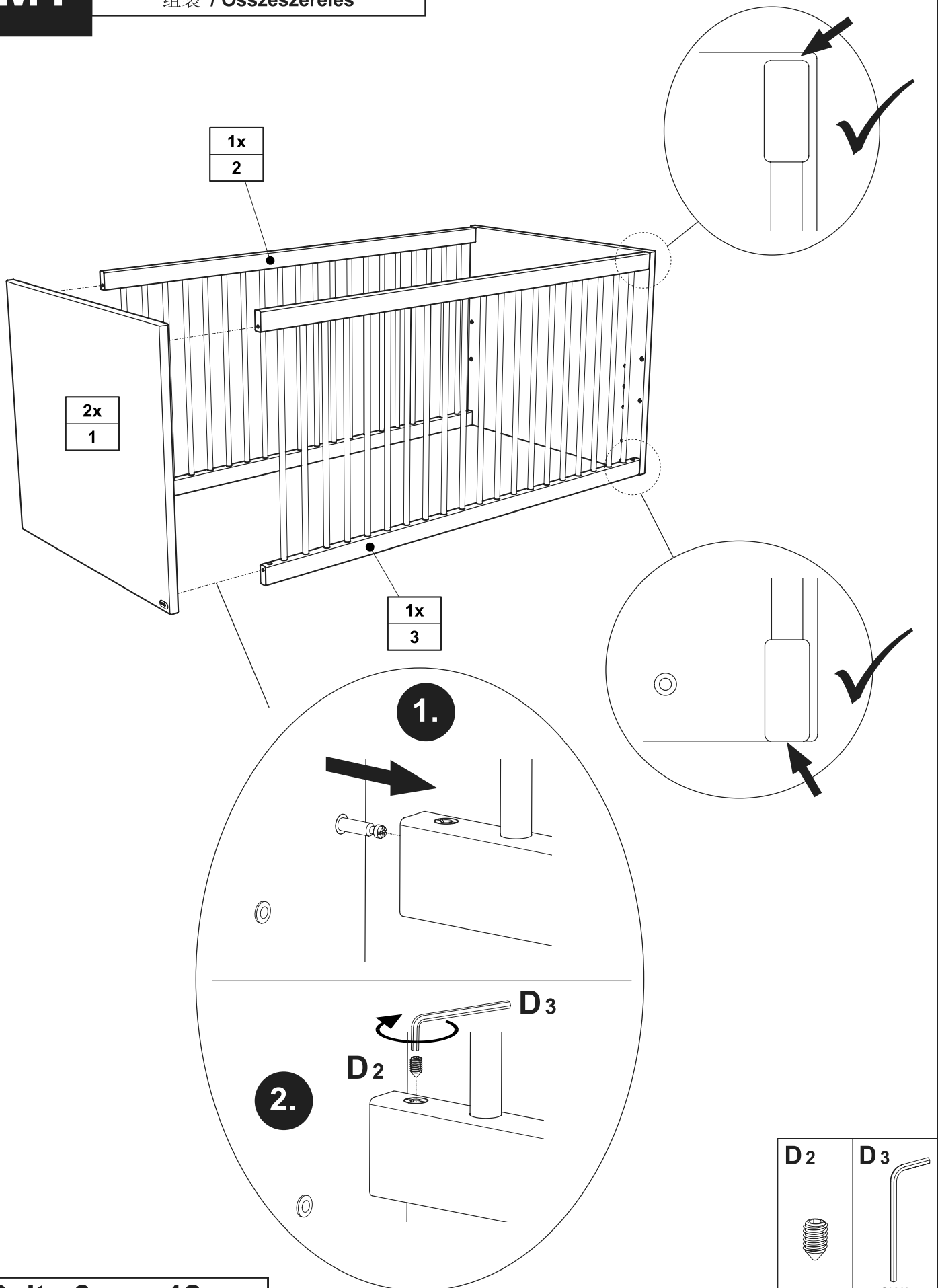

M1

Montage / Assembly /
Assemblage / Montage / Монтаж /
组装 / Összeszerelés

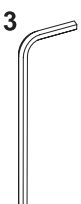

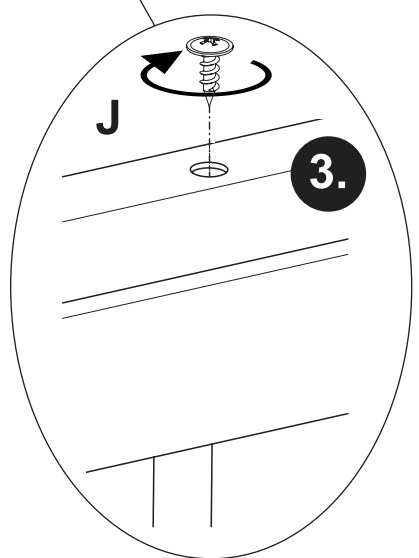
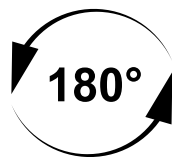
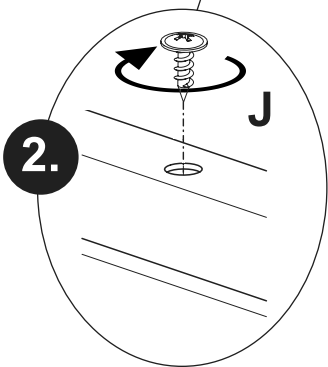
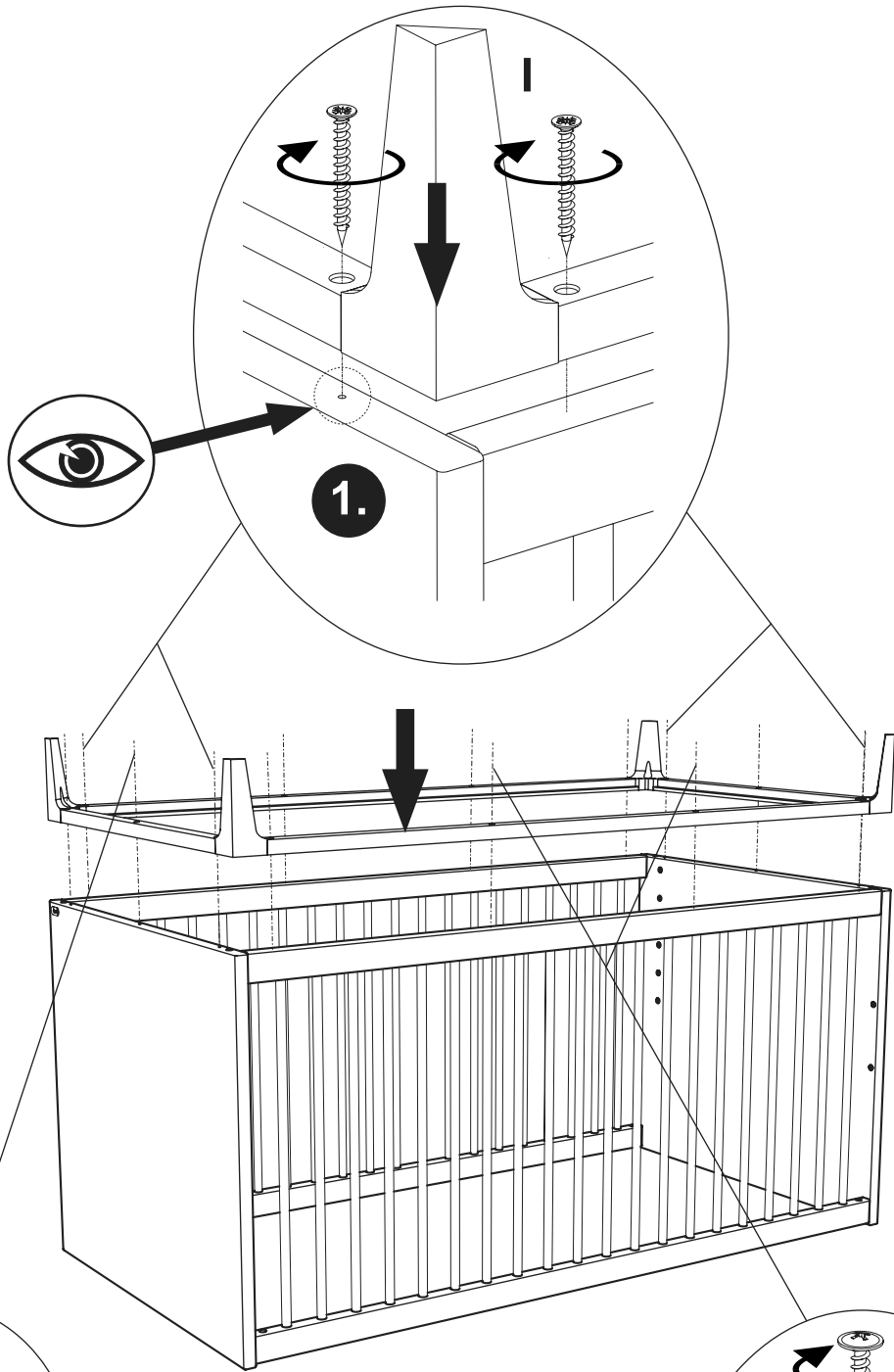
D2	D3
	
8x 681 0784	SW3 1x 681 3009

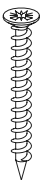

I	J
	
4,0 x 40 8x 681 4907	4 x 13 6x 681 4927

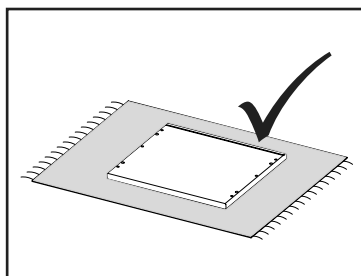

M3

2.

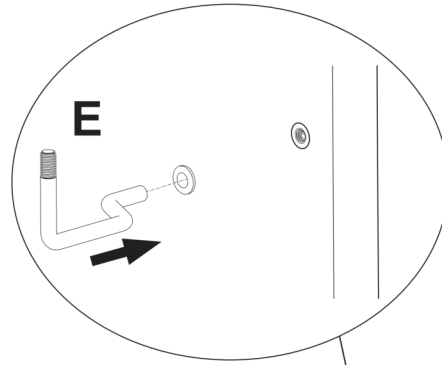
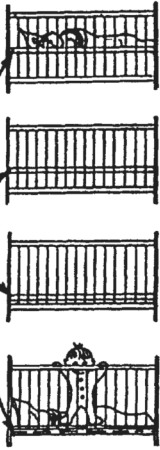



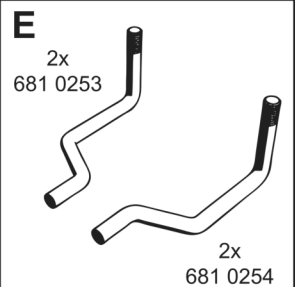
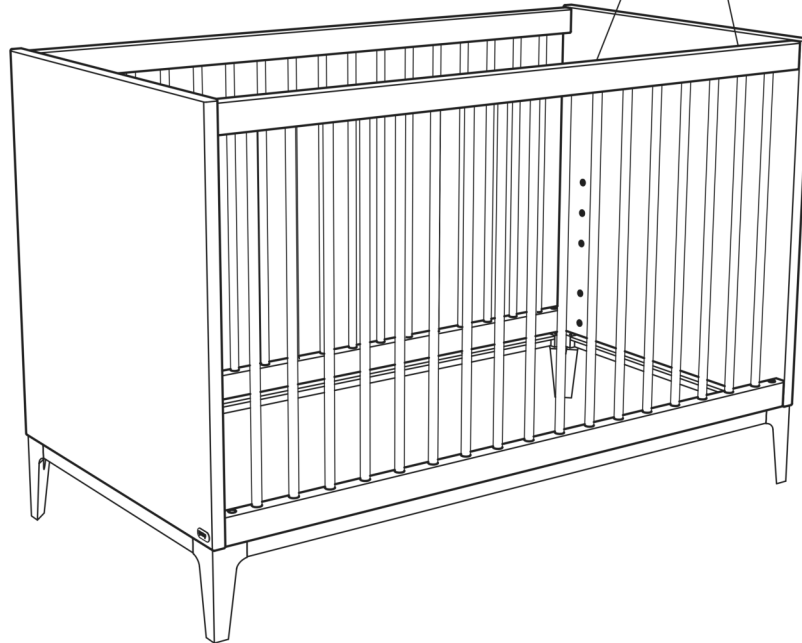
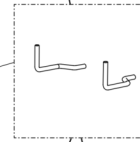

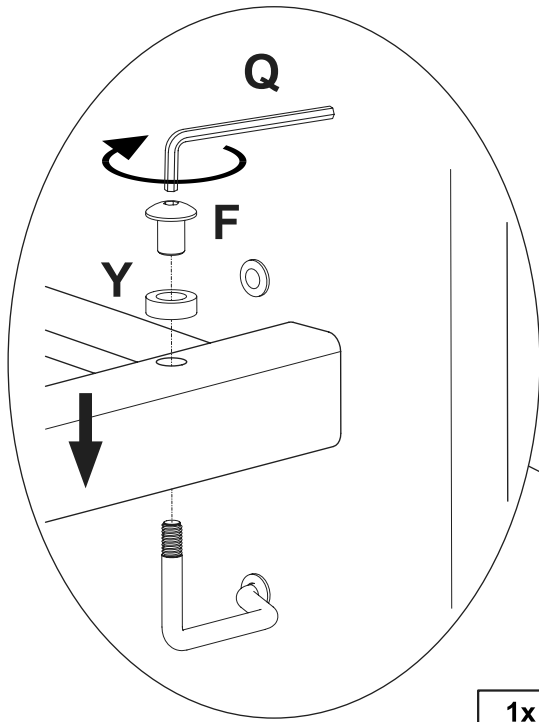
2x
E



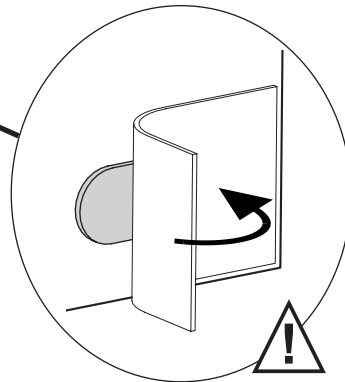
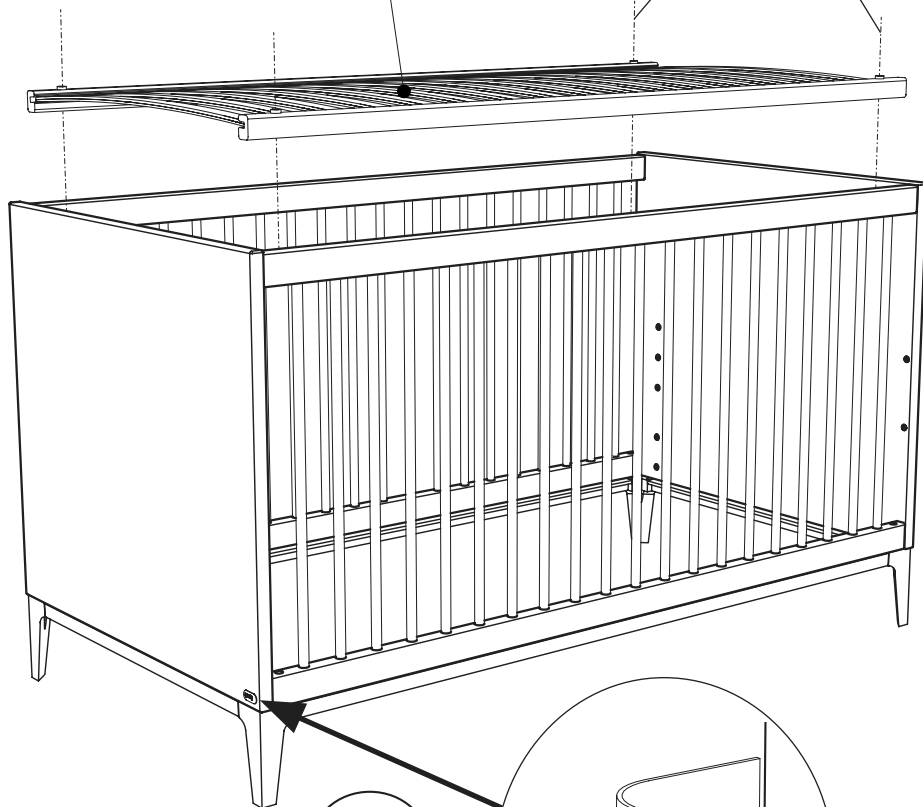

1x
4

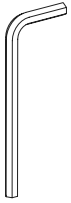

F	Q	Y
		
4x 681 2047	SW4 1x 681 3011	4x 681 8863

Gebruiksaanleitung Umbau zum Juniorbett

User instructions for conversion to junior bed / Mode d'emploi Transformation en lit pour enfant / Gebruiksaanwijzing ombouw tot juniorbed / Инструкция по эксплуатации переоборудование в детскую кровать / 改装成儿童床的用户说明

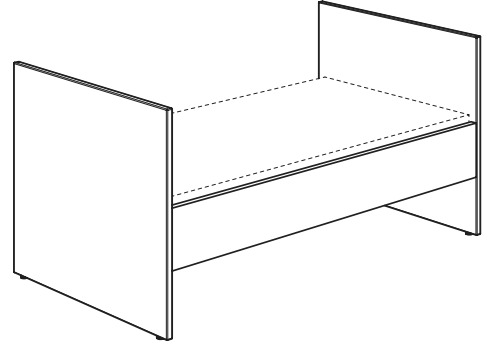
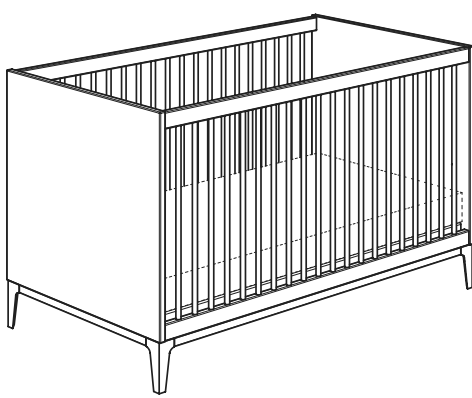

V1

Vorbereitung / Preparation /
Préparation / Voorbereiding /
Подготовка / 准备 / Előkészítés

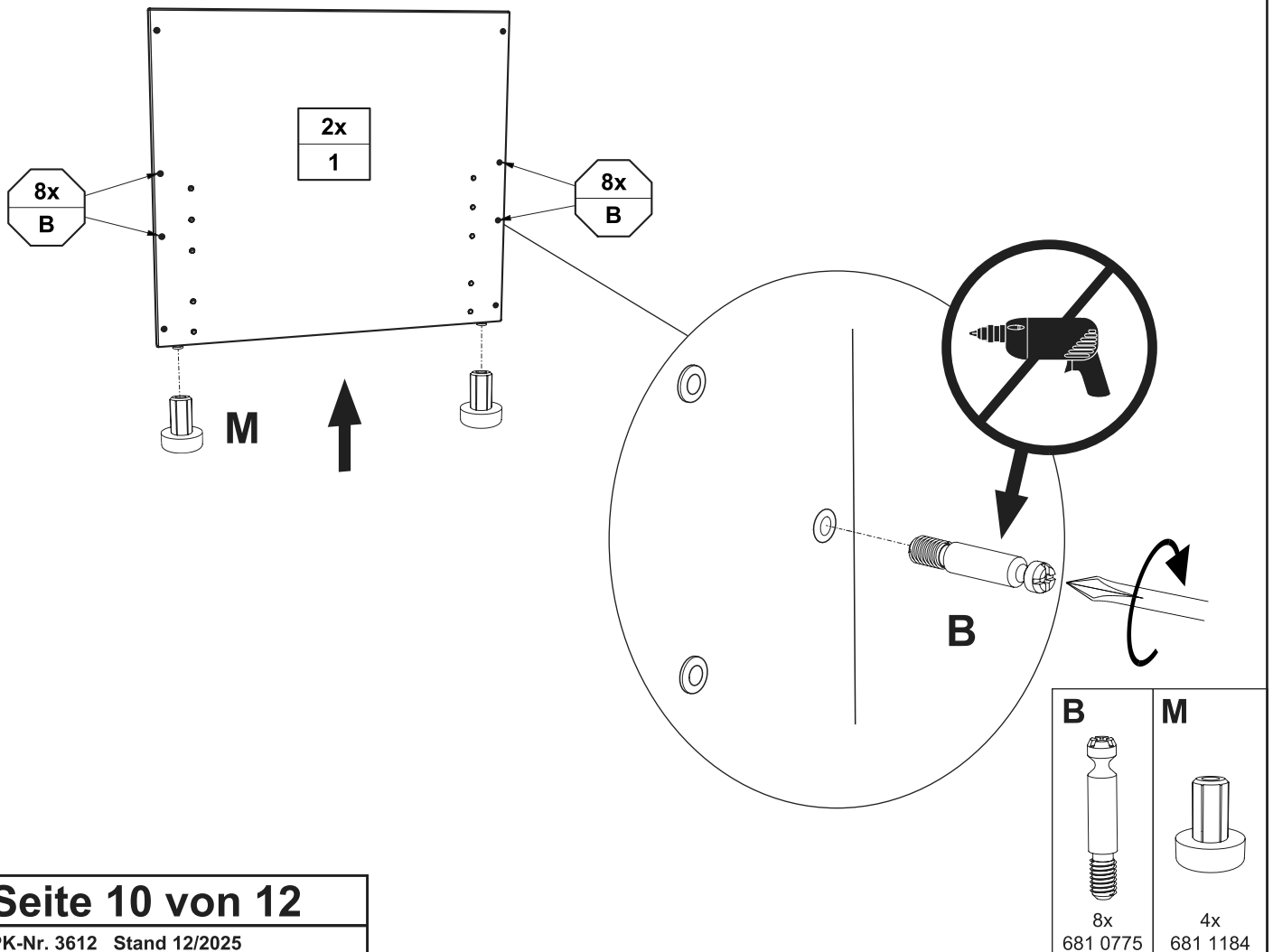

Umbauseiten sind nicht im Lieferumfang enthalten. **Separat bestellen!**

Conversion sides are not included. **Order separately!**

Les côtés ne sont pas inclus dans la livraison. **À commander séparément!**

Ombouwzijkanten zijn niet inbegrepen in de levering. **Apart bestellen!**

Переставные боковины не входят в комплект поставки. **Они заказываются отдельно!**

不包括转换用的侧面床架，须单独订购!



V2

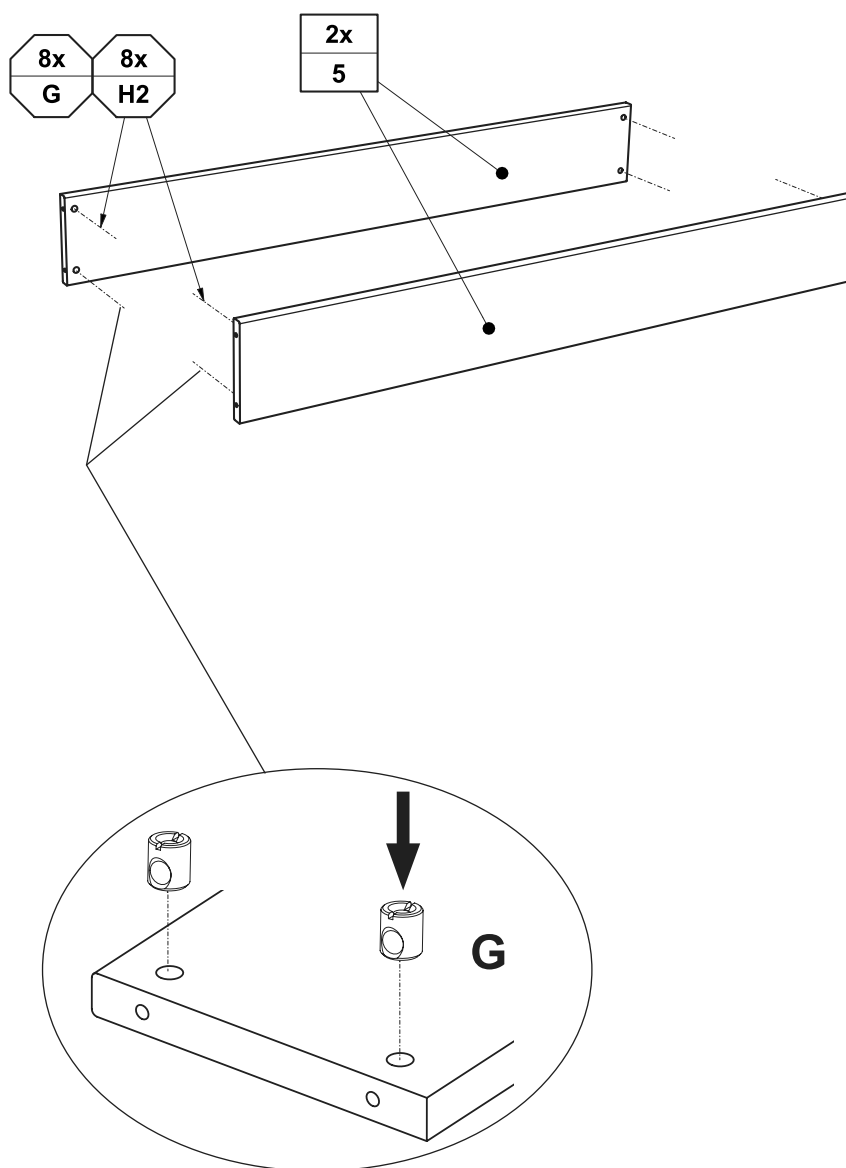

G

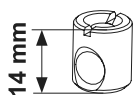

8x
681 0776

Seite 11 von 12

PK-Nr. 3612 Stand 12/2025

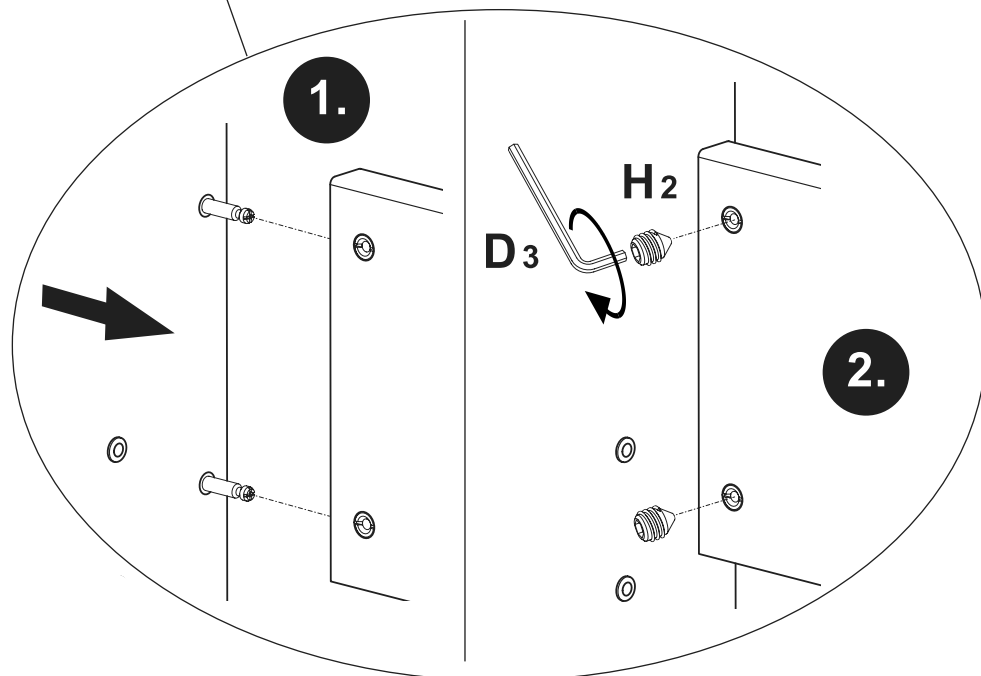
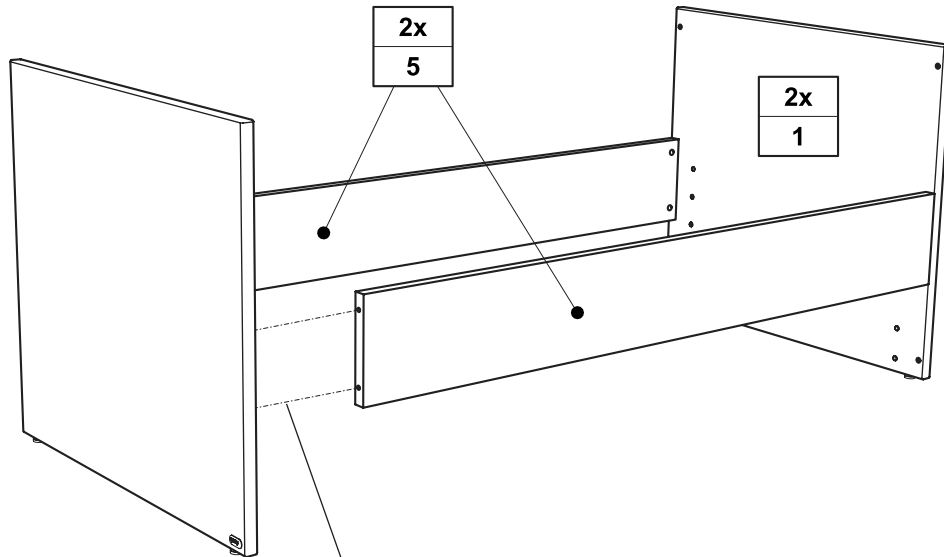

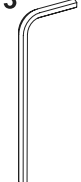
H2	D3
	
8x 681 0787	SW3 1x 681 3009