

NOTICE DE MONTAGE
 ASSEMBLING INSTRUCTIONS
 MONTAGEANLEITUNG
 ISTRUZIONI DI MONTAGGIO
 INSTRUCOES DE MONTAGEM
 INSTRUCCIONES DE MONTAJE
 UPUTE ZA MONTAZU
 MONTAJ TALIMATI
 MONTAGE-INSTRUCTIES

Version: 22/07/2025

CHEVET 2T MOSAIK

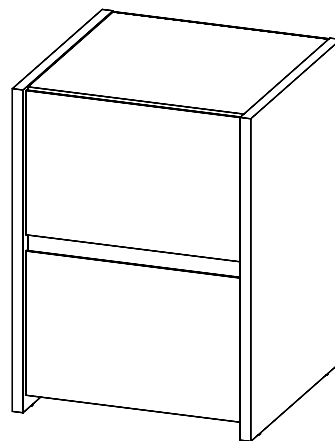

Code EN13	Reférence	Codification	Coloris
3605096124332	612433	116568	HIKORY
3605096128965	612896	116569	BLANC
3605096129252	612925	116572	BLEU NUIT
3605096129337	612933	116570	TERRA
3605096129412	612941	116573	SABLE

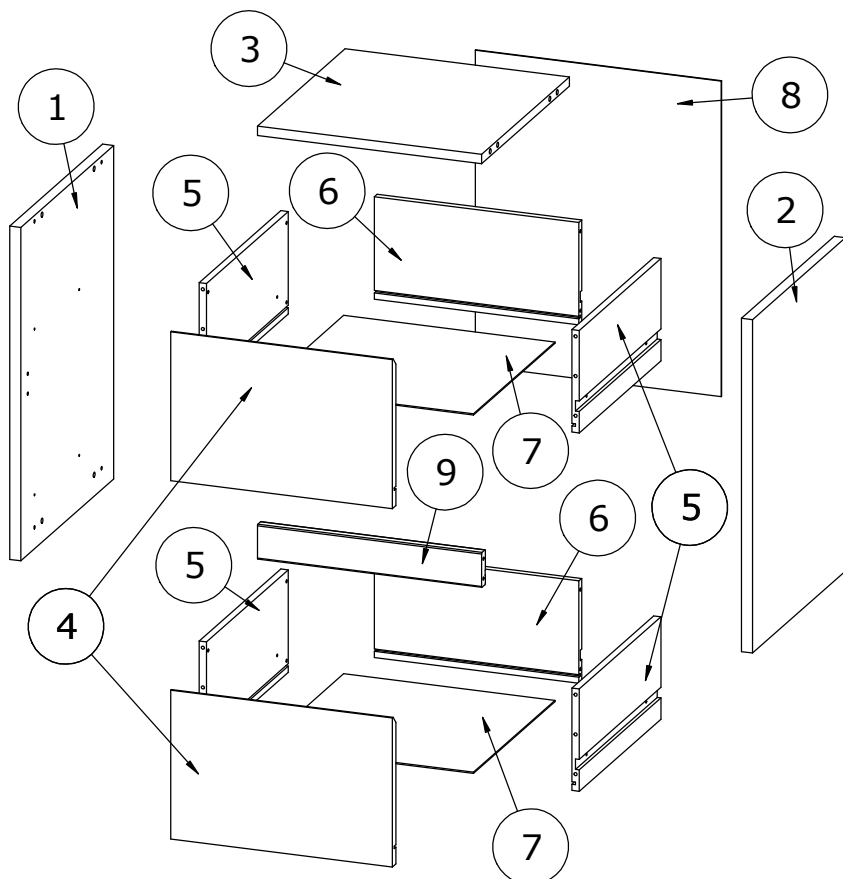
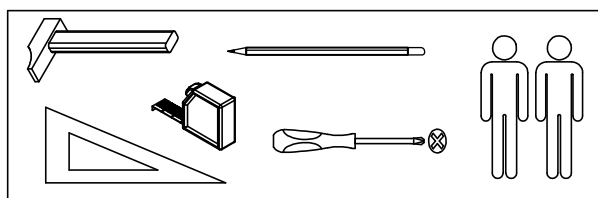

N°	DIM 1 (mm)	DIM 2 (mm)	DIM 3 (mm)	n° Colis
1	537	399	18	1/1
2	537	399	18	1/1
3	377	364	15	1/1
4	360	240	15	1/1
5	351	165	12	1/1
6	332	165	12	1/1
7	350	343	2	1/1
8	508	399	2	1/1
9	364	56	16	1/1



F**INFORMATIONS/AVERTISSEMENTS**

Meuble à monter soi-même :

- Utiliser une protection pour éviter le contact des pièces avec le sol.
- Vérifier la présence et l'état de la quincaillerie et des pièces avant de débiter le montage.
- Tenir éloigné les jeunes enfants lors de l'assemblage. (présence de petites pièces susceptibles d'être ingérées)
- Ne pas monter ou utiliser le mobilier si certains éléments sont cassés, endommagés ou manquants, et n'utiliser que des pièces détachées approuvées par le fabricant.
- Utiliser uniquement l'outillage fourni ou préconisé sur la notice de montage.

GB**INFORMATION/WARNINGS**

Do-it-yourself furniture:

- Use protection to prevent parts coming into contact with the floor.
- Check that all hardware and parts are present and in good condition before starting assembly.
- Keep small children away from the furniture during assembly (small parts that could be swallowed).
- Do not assemble or use the furniture if any parts are broken, damaged or missing, and only use spare parts approved by the manufacturer.
- Only use the tools supplied or recommended in the assembly instructions.
- Tighten the fasteners correctly using the tools supplied or recommended.
- Incorrect assembly, shimming or handling can lead to weakened assemblies and/or parts.
- Use your product on stabilised, level ground.
- All assembly devices should always be properly tightened and regularly checked, and retightened if necessary.
- Do not move loaded furniture.
- Furniture containing wood-based panels can emit pollutants into the indoor air. We therefore recommend that you air the room frequently for at least four weeks after installing the furniture.

D**INFORMATIONEN/WARNUNGEN**

Möbelstücke zum Selbstaufbauen :

- Verwenden Sie eine Schutzvorrichtung, damit die Teile nicht mit dem Boden in Berührung kommen.
- Überprüfe das Vorhandensein und den Zustand der Beschläge und Teile, bevor du mit dem Zusammenbau beginnst.
- Halten Sie kleine Kinder während des Aufbaus fern (es gibt kleine Teile, die verschluckt werden könnten).
- Bauen Sie die Möbel nicht auf oder verwenden Sie sie nicht, wenn Teile gebrochen, beschädigt sind oder fehlen, und verwenden Sie nur vom Hersteller zugelassene Ersatzteile.
- Verwenden Sie nur die mitgelieferten oder in der Montageanleitung empfohlenen Werkzeuge.
- Ziehen Sie die Befestigungselemente mit dem mitgelieferten oder empfohlenen Werkzeug richtig fest.
- Eine falsche Montage, Verkeilung oder Handhabung kann zu einer Versprödung der Verbindungen und/oder der Teile führen.
- Verwenden Sie Ihr Produkt auf einem stabilen, ebenen Boden.
- Alle Verbindungsteile sollten immer fest angezogen sein und regelmäßig überprüft und gegebenenfalls nachgezogen werden.
- Bewegen Sie keine beladenen Möbel.
- Möbel, die Holzwerkstoffplatten enthalten, können Schadstoffe in die Raumluft abgeben. Es wird daher empfohlen, nach dem Aufbau des Möbelstücks den Raum mindestens vier Wochen lang häufig zu lüften.

I**INFORMAZIONI/AVVERTENZE**

Mobili fai-da-te:

- Utilizzare una protezione per evitare che le parti entrino in contatto con il pavimento.
- Prima di iniziare il montaggio, verificare che tutti i componenti siano presenti e in buone condizioni.
- Tenere i bambini piccoli lontani dai mobili durante il montaggio (le parti piccole potrebbero essere ingerite).
- Non montare o utilizzare il mobile se alcune parti sono rotte, danneggiate o mancanti e utilizzare solo ricambi approvati dal produttore.
- Utilizzare solo gli strumenti forniti o consigliati nelle istruzioni di montaggio.
- Serrare correttamente gli elementi di fissaggio utilizzando gli strumenti forniti o consigliati.
- Un montaggio, uno spessoramento o una manipolazione errati possono causare l'indebolimento dei gruppi e/o delle parti.
- Utilizzare il prodotto su un terreno stabilizzato e in piano.
- Tutti i dispositivi di montaggio devono essere sempre serrati correttamente e controllati regolarmente, e se necessario serrati nuovamente.
- Non spostare mobili carichi.
- I mobili contenenti pannelli in legno possono emettere sostanze inquinanti nell'aria interna. Si consiglia pertanto di aerare frequentemente la stanza per almeno quattro settimane dopo l'installazione dei mobili.

E**INFORMACION/ADVERTENCIAS**

Muebles de bricolaje:

- Utilice protección para evitar que las piezas entren en contacto con el suelo.
- Compruebe que todos los herrajes y piezas están presentes y en buen estado antes de iniciar el montaje.
- Mantenga a los niños pequeños alejados del mueble durante el montaje (piezas pequeñas que podrían tragarse).
- No monte ni utilice el mueble si alguna pieza está rota, dañada o falta, y utilice únicamente piezas de repuesto homologadas por el fabricante.
- Utilice únicamente las herramientas suministradas o recomendadas en las instrucciones de montaje.
- Apriete correctamente las fijaciones con las herramientas suministradas o recomendadas.
- Un montaje, calce o manipulación incorrectos pueden debilitar los conjuntos y/o las piezas.
- Utilice el producto sobre suelo estabilizado y nivelado.
- Todos los dispositivos de montaje deben estar siempre bien apretados y comprobados periódicamente, y reapretados en caso necesario.
- No mueva muebles cargados.
- Los muebles que contienen paneles de madera pueden emitir contaminantes al aire interior. Por ello, le recomendamos que ventile la habitación con frecuencia durante al menos cuatro semanas después de instalar el mueble.

P**INFORMACOES/AVISOS**

Mobiliário "faça você mesmo":

- Utilize uma proteção para evitar que as peças entrem em contacto com o chão.
- Verificar se todas as ferragens e peças estão presentes e em bom estado antes de iniciar a montagem.
- Manter as crianças pequenas afastadas dos móveis durante a montagem (peças pequenas que podem ser engolidas).
- Não montar nem utilizar o móvel se houver peças partidas, danificadas ou em falta e utilizar apenas peças sobresselentes aprovadas pelo fabricante.
- Utilizar apenas as ferramentas fornecidas ou recomendadas nas instruções de montagem.
- Apertar corretamente os elementos de fixação com as ferramentas fornecidas ou recomendadas.
- Uma montagem, um calço ou um manuseamento incorrectos podem provocar a fragilização dos conjuntos e/ou das peças.
- Utilize o seu produto num terreno estabilizado e nivelado.
- Todos os dispositivos de montagem devem ser sempre corretamente apertados e regularmente verificados e, se necessário, reapertados.
- Não desloque móveis carregados.
- Os móveis que contêm painéis derivados de madeira podem emitir poluentes para o ar interior. Recomendamos, por isso, que areje frequentemente a divisão durante, pelo menos, quatro semanas.

TR**BILGI/UYARILAR**

Kendin yap mobilya:

- Parçaların zeminle temas etmesini önlemek için koruma kullanın.
- Montaja başlamadan önce tüm donanım ve parçaların mevcut ve iyi durumda olduğunu kontrol edin.
- Montaj sırasında küçük çocukları mobilyadan uzak tutun (küçük parçalar yutulabilir).
- Herhangi bir parça kırık, hasarlı veya eksikse mobilyayı monte etmeyin veya kullanmayın ve yalnızca üretici tarafından onaylanan yedek parçaları kullanın.
- Yalnızca birlikte verilen veya montaj talimatlarında önerilen aletleri kullanın.
- Bağlantı elemanlarını verilen veya önerilen aletleri kullanarak doğru şekilde sıkın.
- Yanlış montaj, düzeltme veya taşıma, montajların ve/veya parçaların zayıflamasına neden olabilir.
- Ürününüzü stabilize ve düz bir zeminde kullanın.
- Tüm montaj cihazları her zaman uygun şekilde sıkılmalı, düzenli olarak kontrol edilmeli ve gerekirse yeniden sıkılmalıdır.
- Yüklü mobilyaları hareket ettirmeyin.
- Aşşap bazlı paneller içeren mobilyalar iç mekan havasına kirlenici maddeler yayabilir. Bu nedenle mobilyayı kurduktan sonra en az dört hafta boyunca odayı sık sık havalandırmanızı öneririz.

HR**INFORMACIJE/UPOZORENJA**

Namještaj za samostalnu montažu:

- Koristite zaštitu kako biste spriječili kontakt dijelova s tlom.
- Proverite prisutnost i stanje pribora i dijelova prije početka montaže.
- Držite malu djecu podalje tijekom sastavljanja. (prisutnost malih dijelova koji se mogu progutati)
- Ne sastavljajte ili koristite namještaj ako su neki dijelovi slomljeni, oštećeni ili nedostaju, i koristite samo rezervne dijelove odobrene od strane proizvođača.
- Koristite samo alat koji je isporučen ili preporučeno u uputama za montažu.
- Ispravno zategnite pričvršćivače pomoću isporučene ili preporučene alata.
- Loša montaža, postavljanje ili rukovanje može uzrokovati slabljenje spojeva i/ili dijelova.
- Koristite svoj proizvod na stabilnom, ravnom terenu.
- Svi uređaji za sastavljanje trebaju biti uvijek pravilno zategnuti i redovito provjeravani, te ponovno zategnuti, ako je potrebno.
- Ne premještajte opterećeni namještaj.
- Namještaj koji sadrži ploče na bazi drva može ispuštati zagađivače u unutarnji zrak. Stoga se preporučuje nakon postavljanja namještaja često provjetravati prostoriju najmanje četiri tjedna.

NL**INFORMATIE/WAARSCHUWINGEN**

Doe-het-zelf-meubels:

- Gebruik bescherming om te voorkomen dat onderdelen in contact komen met de vloer.
- Controleer of alle hardware en onderdelen aanwezig en in goede staat zijn voordat u met de montage begint.
- Houd kleine kinderen uit de buurt van de meubels tijdens de montage (kleine onderdelen die ingeslikt kunnen worden).
- Zet het meubel niet in elkaar en gebruik het niet als er onderdelen kapot zijn, beschadigd zijn of ontbreken en gebruik alleen reserveonderdelen die door de fabrikant zijn goedgekeurd.
- Gebruik alleen het meegeleverde of in de montagehandleiding aanbevolen gereedschap.
- Draai de bevestigingen goed vast met het meegeleverde of aanbevolen gereedschap.
- Onjuiste montage, opvullen of hanteren kan leiden tot verzwakte samenstellingen en/of onderdelen.
- Gebruik uw product op een stabiele, vlakke ondergrond.
- Alle bevestigingsmiddelen moeten altijd goed worden vastgedraaid en regelmatig worden gecontroleerd, en indien nodig opnieuw worden vastgedraaid.
- Verplaats geen beladen meubelen.
- Meubels met op hout gebaseerde panelen kunnen vervuilende stoffen afgeven aan de binnenlucht. We raden daarom aan om de kamer regelmatig te luchten gedurende ten minste vier weken na het installeren van de meubelen.



**LE TRI
+ FACILE**



FR

**Pensez à
donner ou recycler.**



ou



ou



Association

Magasin

Déchèterie

<https://quefairedemesdechets.fr>

F CONSEILS D'ENTRETIEN :

- 1) Dépoussiérez soigneusement.
- 2) Humectez un chiffon doux et propre, d'eau légèrement savonneuse.
Ne jamais utiliser de produits abrasifs : poudre, laine d'acier, solvants.
Ne pas mouiller copieusement.

**NE JAMAIS FORCER LES ASSEMBLAGES
RESSERRER LES VIS APRES QUELQUES TEMPS D'USAGE
GARDER VOTRE NOTICE DE MONTAGE, SI UNE PIECE
VENAIT A MANQUER, ELLE SERAIT LE PLUS CLAIR MOYEN
DE COMMUNIQUER AVEC VOTRE MAGASIN.**



GB NOTICE FOR MAINTENANCE :

- 1) Dust of carefully.
- 2) Use a soft, proper and humid duster and light soap solution to clean the furniture.
Please do not use any scouring agent like powder, steel wool, solvents.
Do not wet too much.

**NEVER FORCE THE CONNECTIONS
RE-TIGHTEN THE SCREWS AFTER FEW DAYS.
PLEASE RETAIN THE AI LEAFLET FOR FUTURE REFERENCE,
THE AI CONTAINS INFORMATION WHEN CLAIMING
FOR MISSING PARTS.**



D PFLEGEHINWEISE :

- 1) Sorgfältig entstauben.
- 2) Mit einem weichen, sauberen und feuchten Tuch und leichter Seifenlauge reinigen.
Benutzen Sie keine Scheuermittel wie Pulver, Stahlwolle, Lösungsmittel.
Nicht zu nass abwischen.

**NIEMALS DIE VERBINDUNGEN ZU STARCK ANZIEHEN
DIE SCHRAUBEN NACH EINIGER ZEIT DES GEBRAUCHS
ERNEUT FESTZIEHEN. DIE MONTAGEANLEITUNG GUT
AUFBEWAHREN, SOLLTE EIN TEIL FEHLEN, IST SIE DAS
BESTE VERSTÄNDIGUNGSMITTEL MIT IHREM GESCHAFT.**



I CONSIGLI PER LA MANUTENZIONE :

- 1) Spolverate accuratamente.
- 2) Inumidire con acqua leggermente insaponata uno straccio morbido e pulito.
Non utilizzare mai prodotti abrasivi : polvere, lana di acciaio, solventi.
Non bagnare troppo.

**NON FORZARE MAI GLI ASSEMBLAGGI
RISTRINGERE LE VITI DOPO UN PERIODO D'USO
CONSERVARE QUESTE ISTRUZIONI DI MONTAGGIO, SE
UN PEZZO VENISSE A MANCARE SAREBBE IL MIGLIORE
MEZZO DI COMUNICAZIONE CON IL RIVENDITORE.**



E RECOMENDACIONES PARA EL MANTENIMIENTO :

- 1) Despolvorear cuidadosamente.
- 2) Humedecer un pano suave y limpio con agua ligeramente enjabonada.
No use nunca productos abrasivos tales como : polvo de limpiar, lana de acero, solventes.
No mojar exageradamente.

**NO FUERCE NUNCA EN LAS UNIONES . APRIETE LOS
TORNILLOS DESPUES DE CIERTO TIEMPO DE UTILIZACION
CONSERVE SU MANUAL DE MONTAJE, SI FALTARA UNA
PIEZA, SERIA LA MANERA MAS FACIL DE COMUNICAR
CON LA TIENDA.**



P NORMAS DE MANUTENCAO :

- 1) Eliminar bem o po.
- 2) Umedecer um pano suave e limpo com agua e um pouco de sabao.
Nunca utilizar produtos abrasivos : pos, la de aço, solventes.
Nao molhar demasiado.

**NUNCA FORCAR OS ENCAIXES.REAPERTAR OS
PARAFUSOS APOS UM TEMPO DE UTILIZACAO.
GUARDAR AS INSTRUCOES DE MONTAGEM.
CASO FALTE ALGUMA PECA , O MAIS A CONSELHVEL
E CONTATAR O REVENDEDOR.**



TR BAKIM TALIMATLARI :

- 1) Tozunu dikkatlice aliniz.
- 2) Yumusak bir bezi temiz su ve az miktarda sabunla (deterjan) nemlendiriniz
- Asla asindirici ürünler kullanmayiniz : Celik yünü, solvent
- Bol suyla yikamayiniz.

**MONTAJLARI ZORLAMAYINIZ.
BIRKAC KULLANIMDAN SONRA VIDALARI SIKISTIRINIZ.
BIR PARCANIN KAYBOLMASI DURUMUNDA MAGAZANIZ-
LADAHHA KOLAY ILETISIME GECEBILMENIZ ICIN MONTAJ
KULLANIM TALIMATINIZI SAKLAYINIZ.**



HR UPUTE ZA ODRZAVANJE :

- 1) Pazljivo obrisati prasinu.
- 2) Koristite suhu krpu.
- Zabranjena je upotreba kemikalija ili bilo kakvih pomocnih sredstava za ribanje jakih sredstava za ciscenje ili celigne vune
- Ne mokra.

**NEMOJTE UPOTREBLJAVATI SILU PRILIKOM SKLAPANJA
NAKON NEKOG VREMENA PONOVRNO PRITEGNITE VIJKE
CUVAJTE UPUTE ZA MONTAZU
U SLUCAJU NEDOSTATKA NEKOG DIJELA NAJBOJE CE BITI
DA KONTAKIRATE PRODAJNO MJESTO.**







NL VEILIGHEIDS MAATREGELEN

- 1) Poets voorzichtig.
- 2) Nooit poetsen met veel water of met schurende producten. Gebruik alleen een klamvochtige doek.

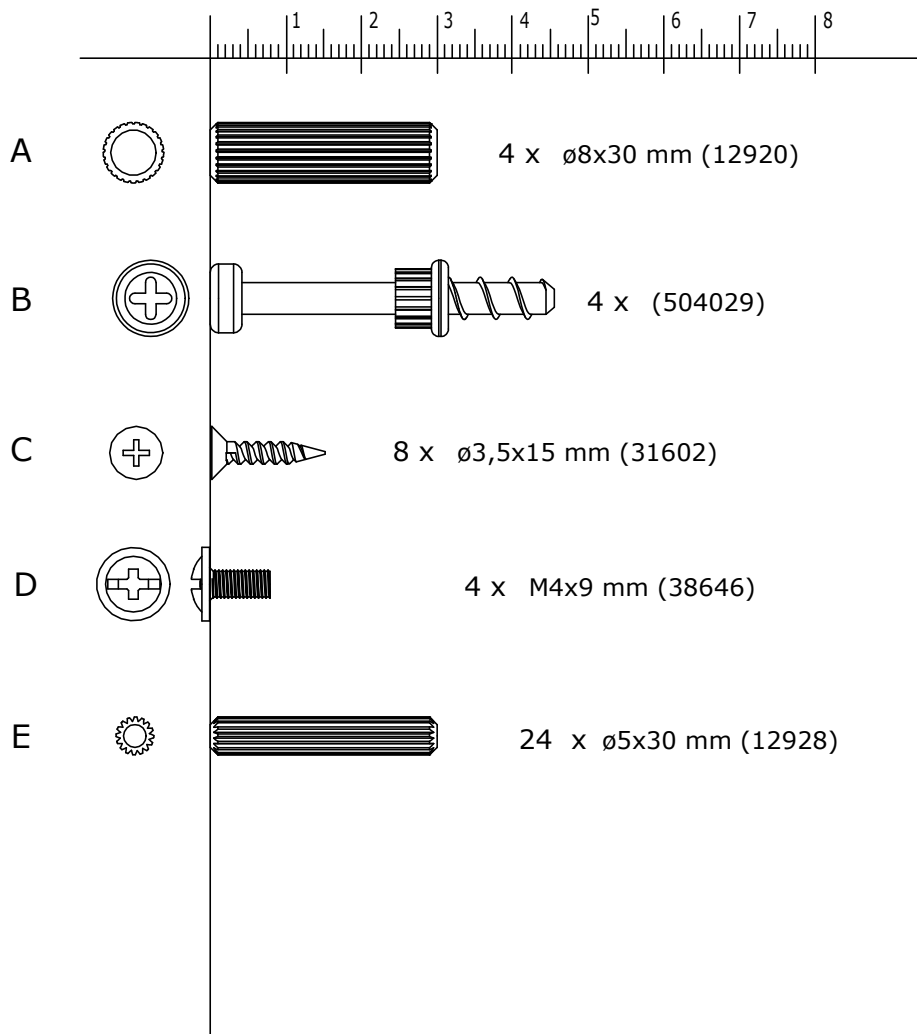
**LET OP ! NOOIT PROBEREN TE FORCEREN TIJDENS
DE MONTAGE VAN UW MEUBILAIR. MOCHT ER IETS
ONTBREKEN NEEM DAN DE MONTAGEHANDLEIDING
MEE NAAR UW VERKOOPPUNT.**



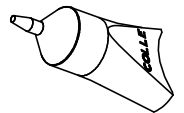

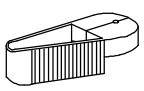
G	500617		4x
H	28403		4x
I	1608794		1x
J	416664		4x
K	512394		1x

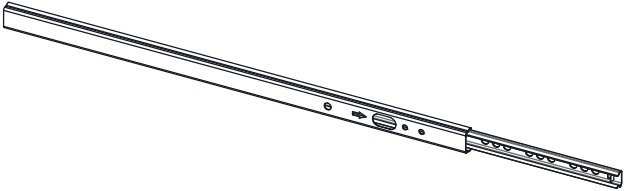
F	438950		1x
L	52140		2x 2 pièces

1

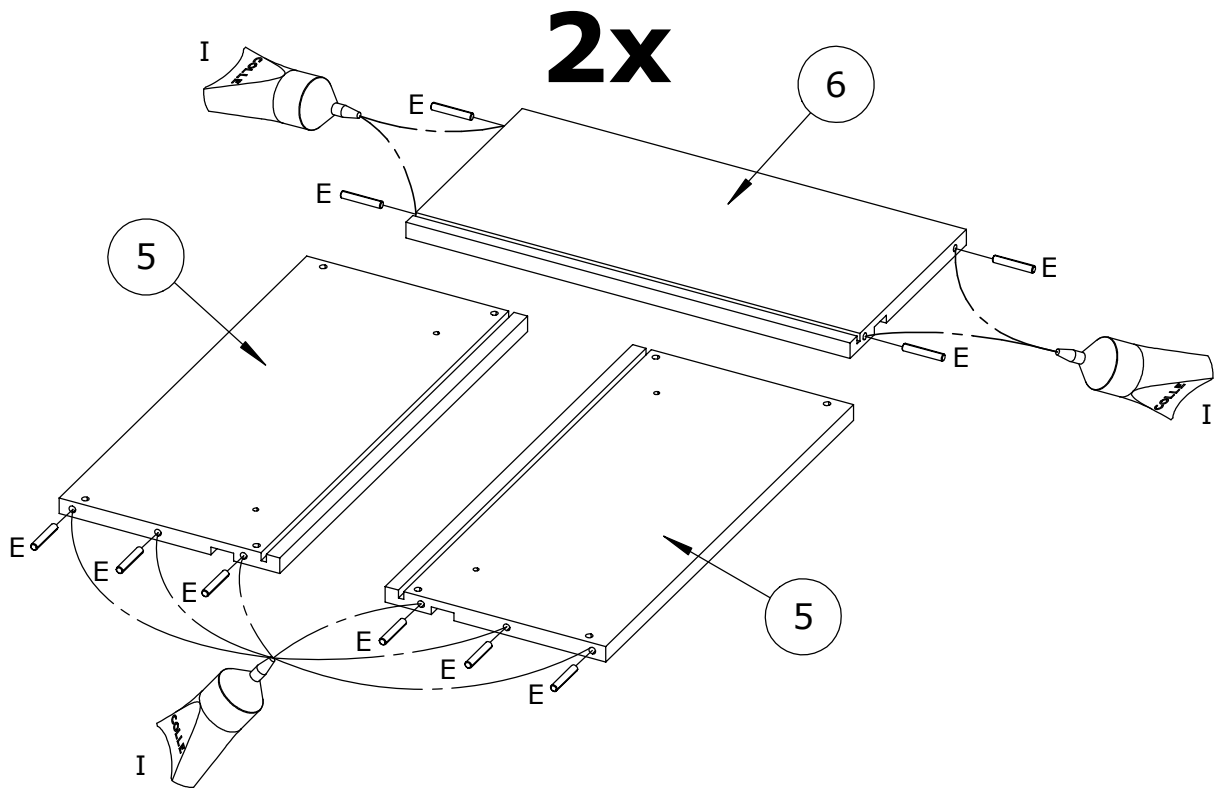
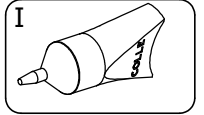
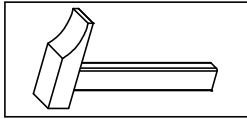

2

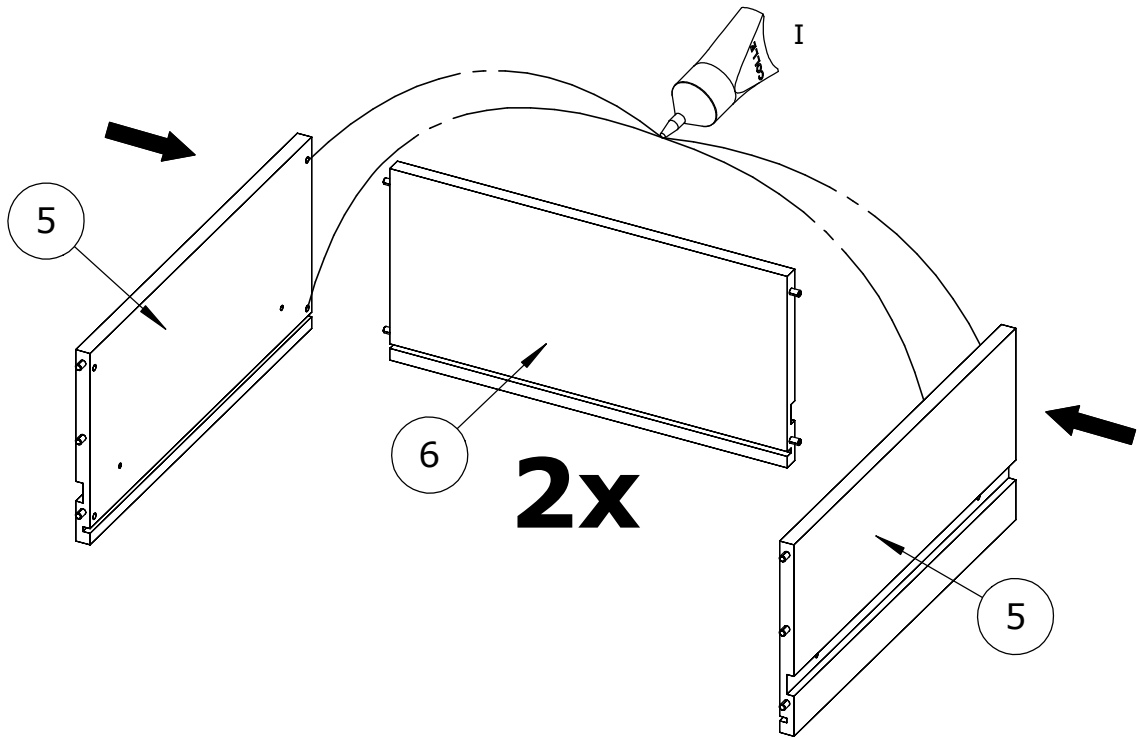
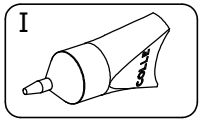
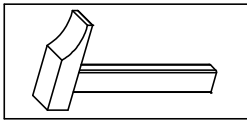

3

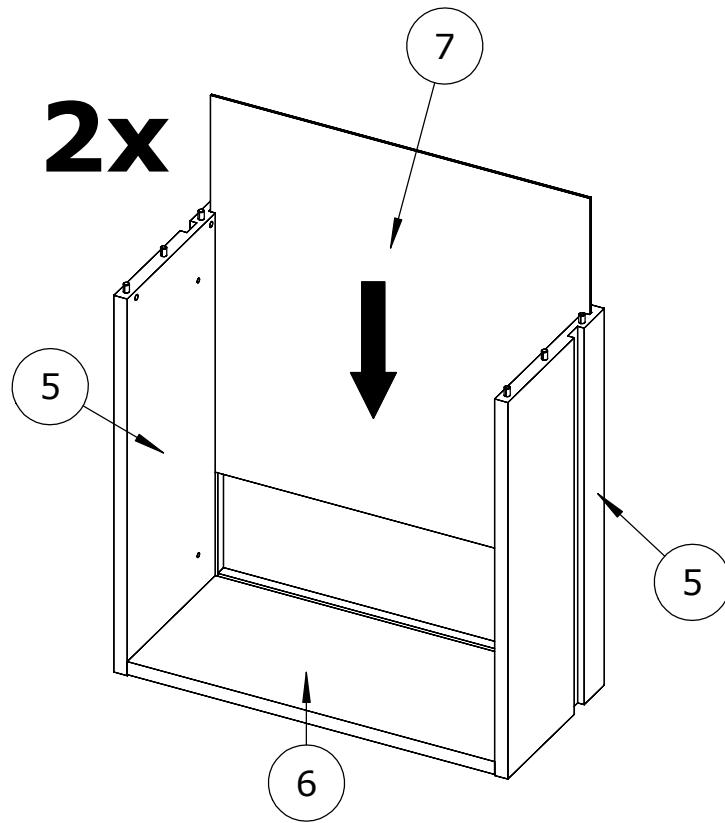

4

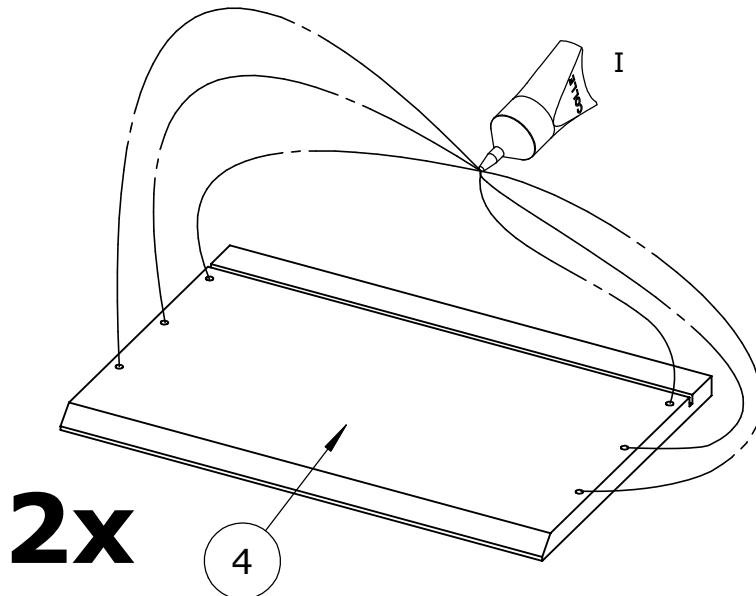
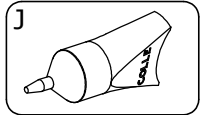

5

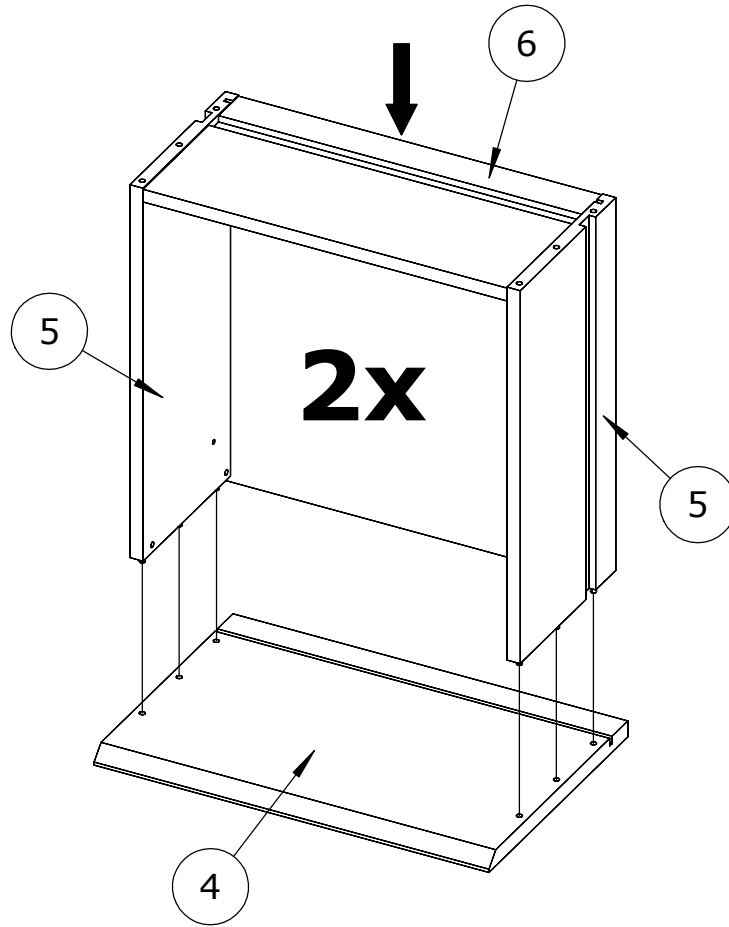

6

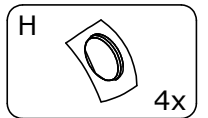
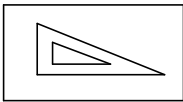

2x

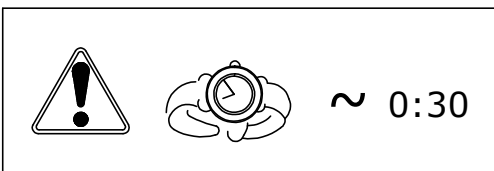
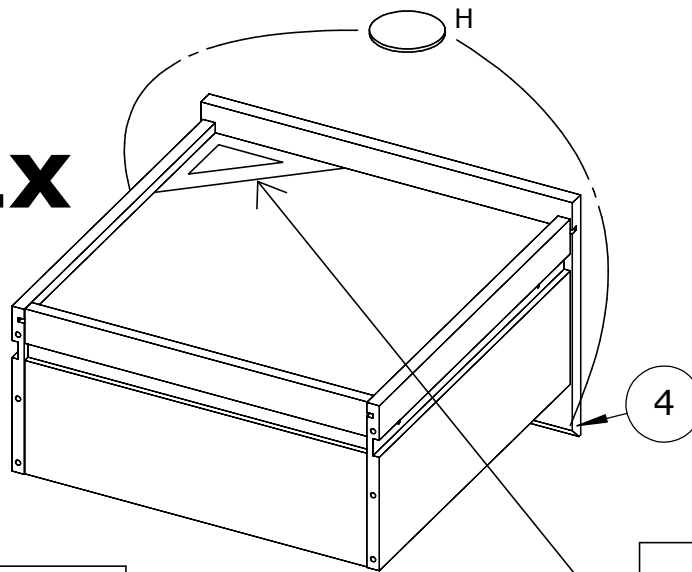

7

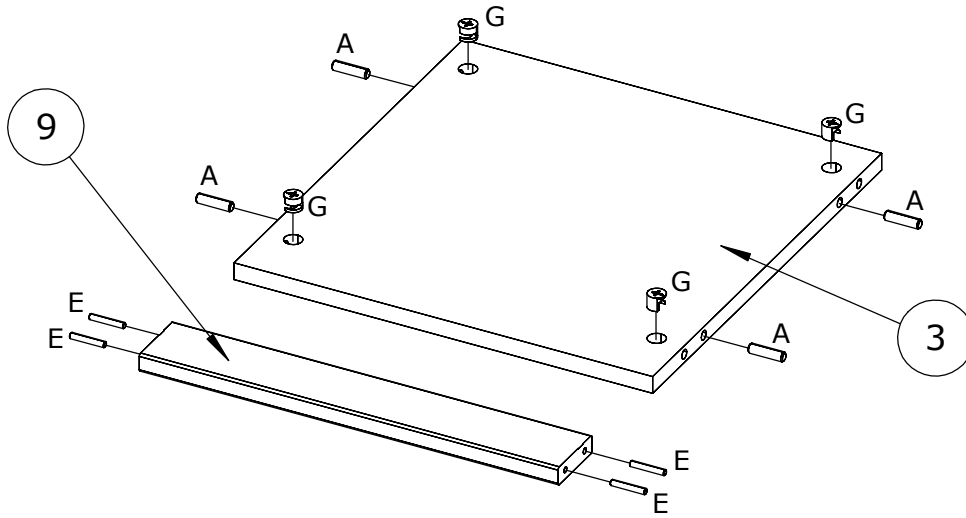
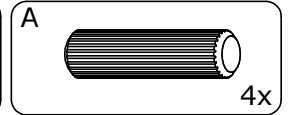
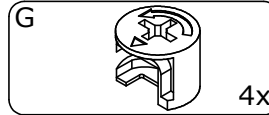
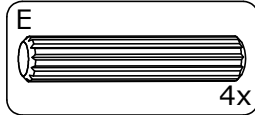
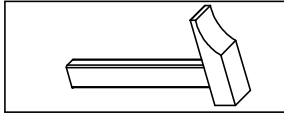

8

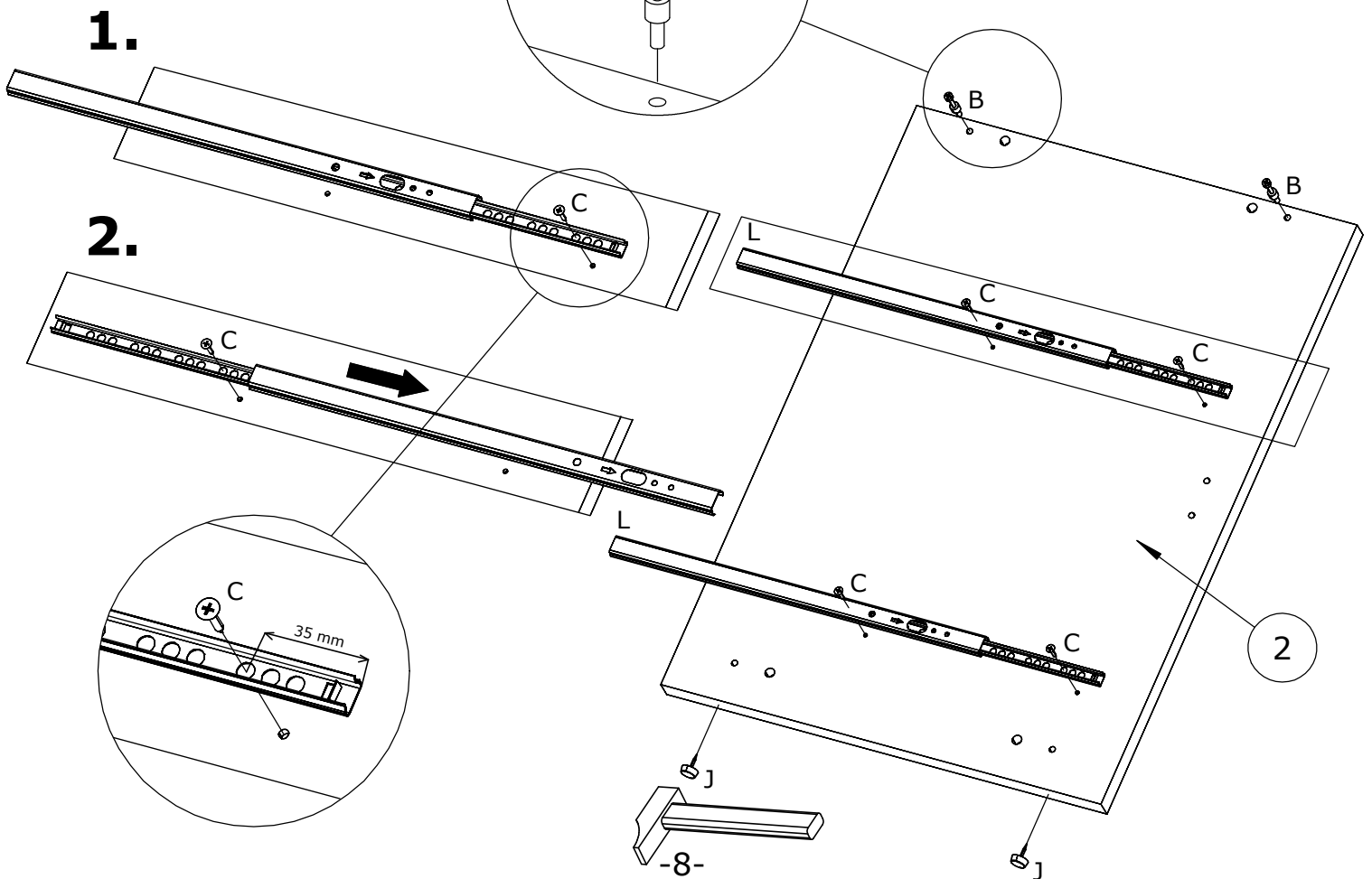
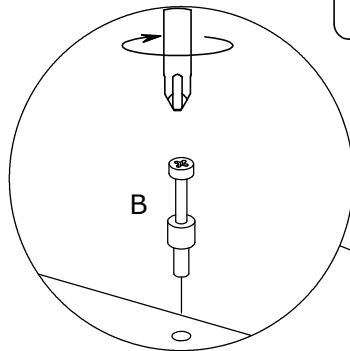
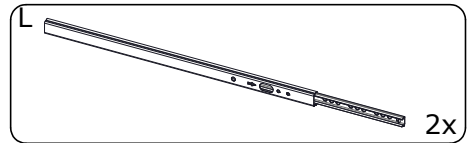
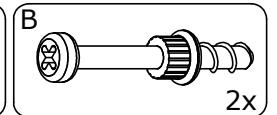
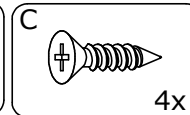
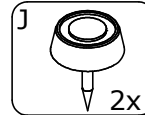
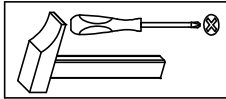

9

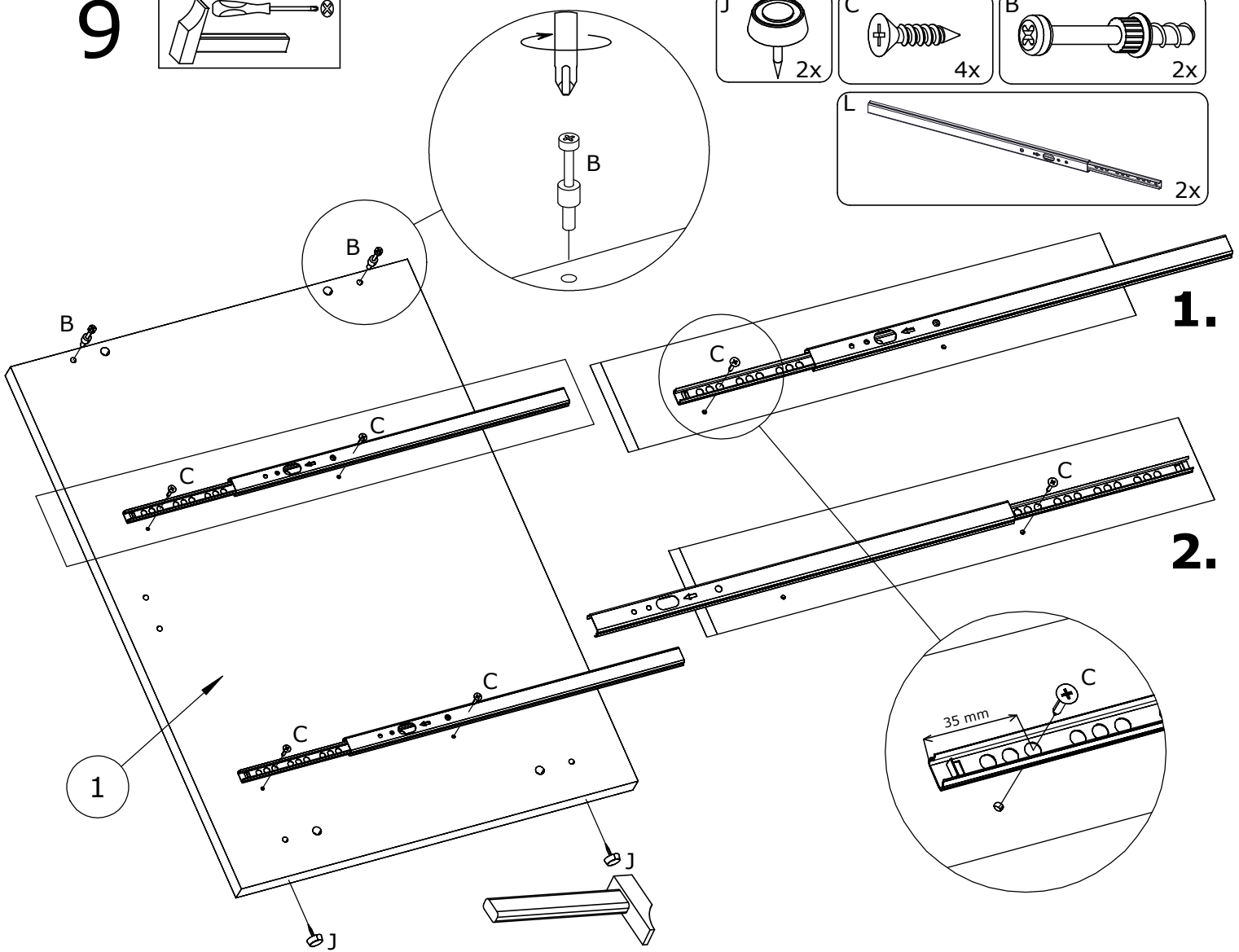
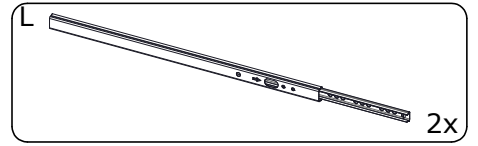
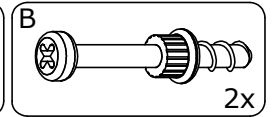
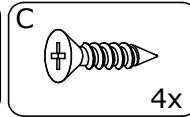
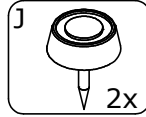
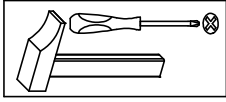

10

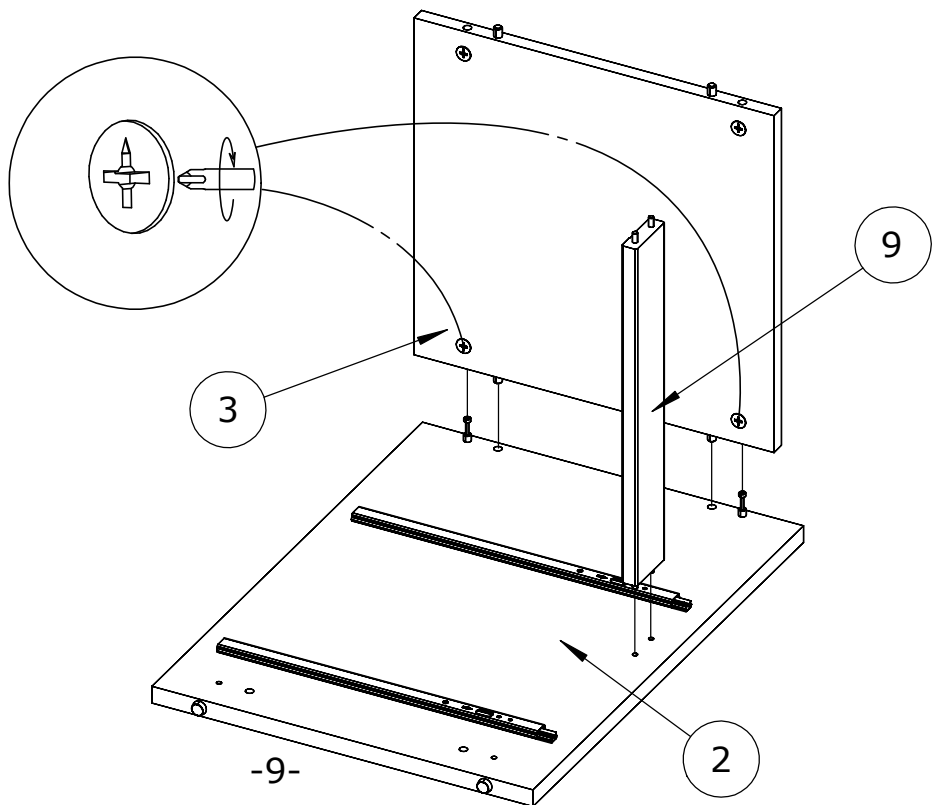
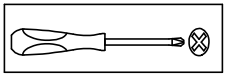

11

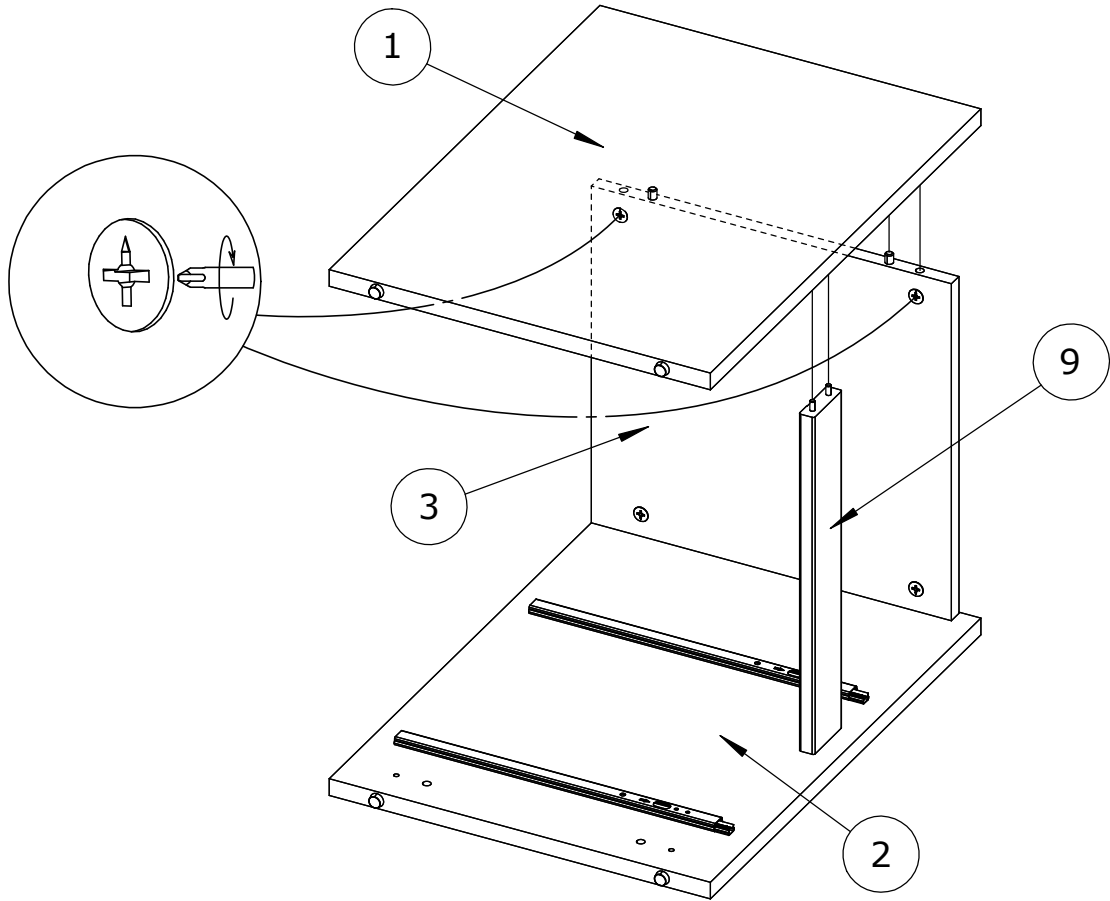
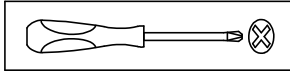

12

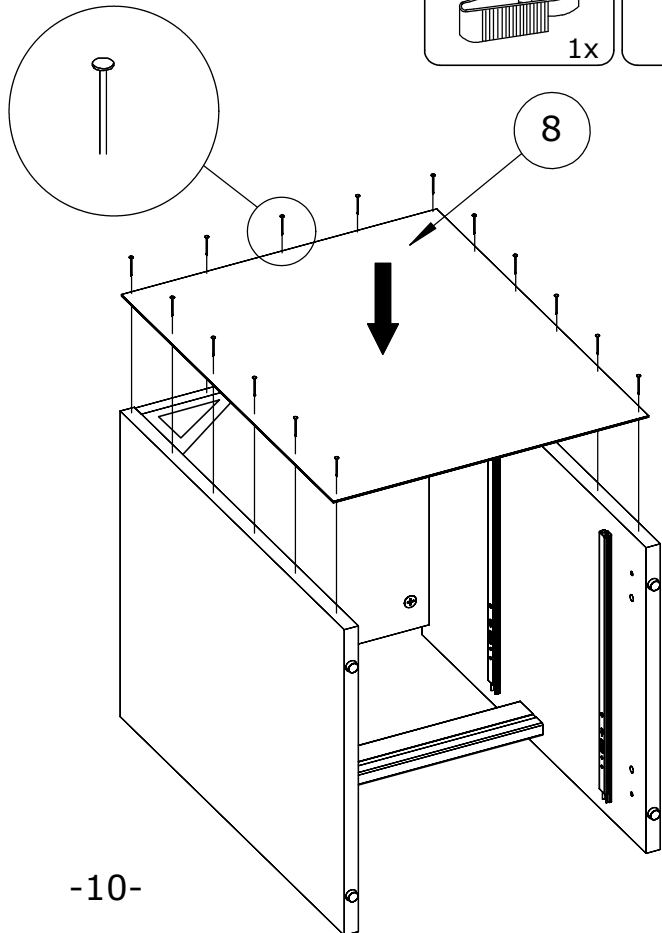
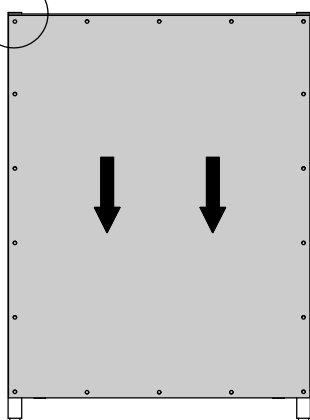
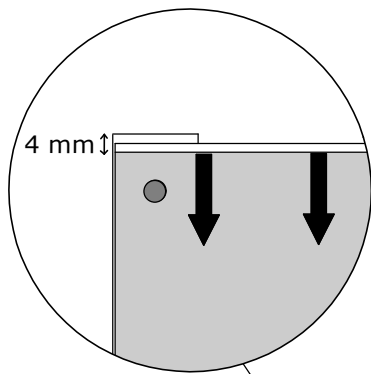
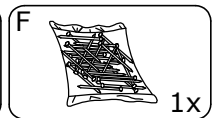
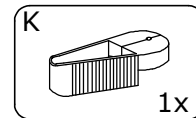
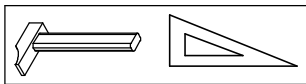

13

