

Gamme : LEIKO

FR Remerciements :

Nous vous remercions d'avoir choisi un meuble créé et fabriqué par le Groupe Parisot et espérons qu'il vous donnera entière satisfaction.

EN Thanks:

Thank you for choosing furniture designed and manufactured by the Parisot Group. We hope you are totally satisfied with your purchase.

DE Danksagung:

Wir danken Ihnen für den Kauf eines Frankreich von der Parisot-Gruppe entworfenen und hergestellten Möbelstücks und hoffen, dass Sie es zu Ihrer vollkommnen Zufriedenheit finden werden.

HU Köszönet:

Köszönjük, hogy a Parisot Groupe által létrehozott és gyártott bútort választott, reméljük, hogy elégedett lesz a termékkel.

PT Agradecimentos:

Obrigado por ter escolhido um móvel projetado e fabricado pelo Grupo Parisot, esperando que seja do seu inteiro agrado.

IT Ringraziamenti:

Grazie per avere scelto un mobile progettato e fabbricato dal Gruppo Parisot. Speriamo soddisfatti appieno le vostre esigenze.

NL Bedankje:

Wij bedanken u voor de aankoop van een door de Groep Parisot ontworpen en vervaardigd meubel en hopen dat u er veel plezier aan zult beleven.

CZ Poděkování:

Děkujeme, že jste si vybrali nábytek navržený a vyrobený společností Parisot Group. Doufáme, že budete svým nákupem naprosto spokojeni.

ES Agradecimientos:

Les damos las gracias por haber elegido un mueble diseñado y fabricado por el Groupe Parisot y esperamos que sea de su total agrado.

PL Podziękowania:

Dziękujemy za wybór mebli stworzonych i wyprodukowanych przez Grupę Parisot. Mamy nadzieję, że będziecie Państwo w pełni zadowoleni z zakupu.

RO Mulțumiri:

Vă mulțumim că ați ales un articol de mobilier conceput și fabricat de Grupul Parisot și sperăm că veți fi pe deplin satisfăcuți de acesta.

RU Благодарность:

Мы благодарим вас за то, что вы выбрали мебель, созданную и произведенную Групп Паризо, и надеемся,

что вы будете полностью удовлетворены нашей продукцией.

SK Pod'akovanie:

Ďakujeme, že ste si vybrali nábytok navrhnutý a vyrobený spoločnosťou Parisot Group. Dúfame, že budete svojim nákupom absolútne spokojní.

SL Hvala:

Hvala, ker ste izbrali pohištvo, ki je dizajnirano in proizvedeno s strani Parisot Group. Upamo, da ste maksimalno zadovoljni z vašim nakupom.

TR Teşekkür ederiz:

Parisot Group tarafından tasarlanan ve üretilen bu mobilyayı seçtiğiniz için teşekkür ederiz. Ürünümüzden memnun kalmanızı ümit ederiz.

ZH 感谢 :

感谢您选择帕里索集团设计制造的家具。我们希望您对此次购买十分满意、

AR : شكر

نشكركم لاختياركم هذه القطعة من الأثاث من تصميم وتصنيع مجموعة باريزو Parisot ونتمنى أن تتلوا رضاهم.

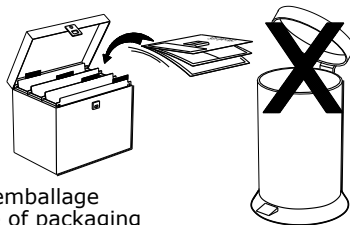

Faites un geste pour l'environnement en triant vos déchets d'emballage
Make a gesture for the environment by sorting out your waste of packaging
Machen Sie eine Bewegung für die Umwelt, ihre Verpackungsabfälle sortierend
Haga un gesto para el medio ambiente escogiendo sus residuos de embalaje
Pensate all'ambiente riciclando i vostri rifiuti di imballaggio
Naredite uslugo okolju in lo ujte odpadke

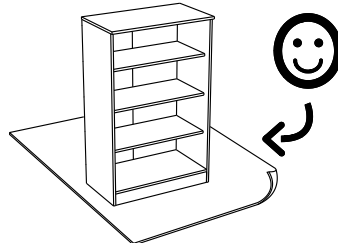
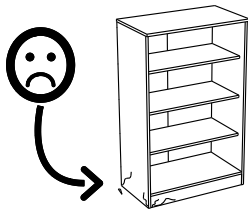
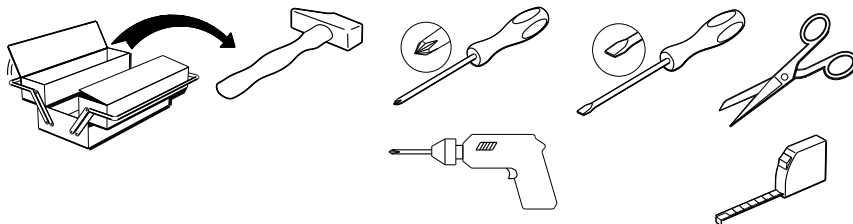

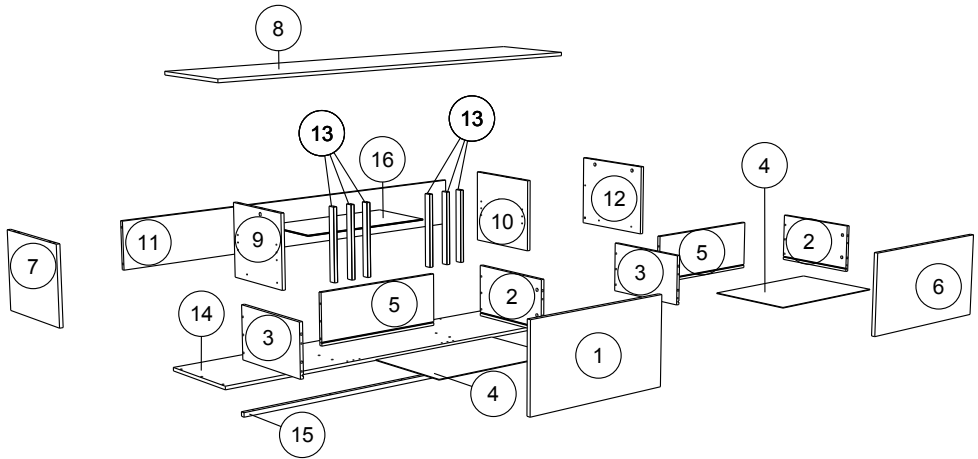
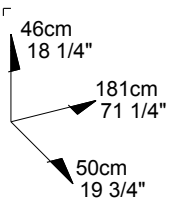

		mm			inch		
13	x 6	320	32	16	12 5/8	1 1/4	5/8
10	x 1	353	320	15	13 7/8	12 5/8	9/16
9	x 1	353	320	15	13 7/8	12 5/8	9/16
12	x 1	398	320	15	15 11/16	12 5/8	9/16
7	x 1	398	320	15	15 11/16	12 5/8	9/16
1	x 1	574	312	15	22 9/16	12 5/16	9/16
6	x 1	574	312	15	22 9/16	12 5/16	9/16
15	x 1	1626	19	19	64	3/4	3/4
11	x 1	1776	214	15	69 15/16	8 7/16	9/16
8	x 1	1808	399	15	71 3/16	15 11/16	9/16
14	x 1	1808	399	15	71 3/16	15 11/16	9/16
2	x 2	350	196	13	13 3/4	7 11/16	1/2
3	x 2	350	196	13	13 3/4	7 11/16	1/2
5	x 2	511	196	13	20 1/8	7 11/16	1/2
4	x 2	523	349	3	20 9/16	13 3/4	1/8
16	x 1	623	321	5	24 1/2	12 5/8	3/16

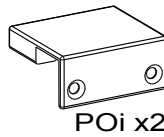
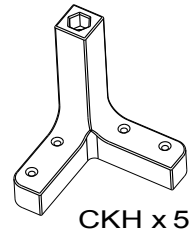
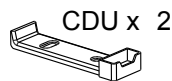
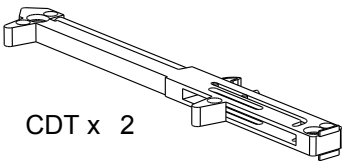
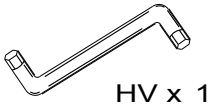
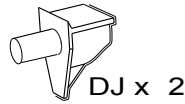
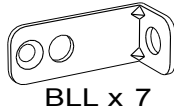
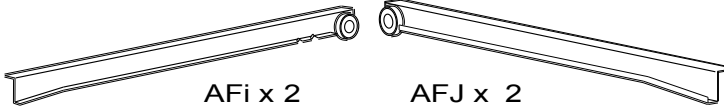
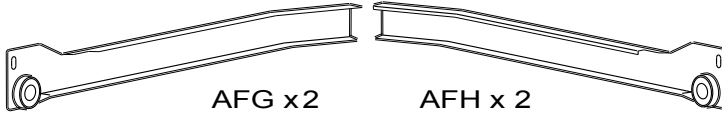

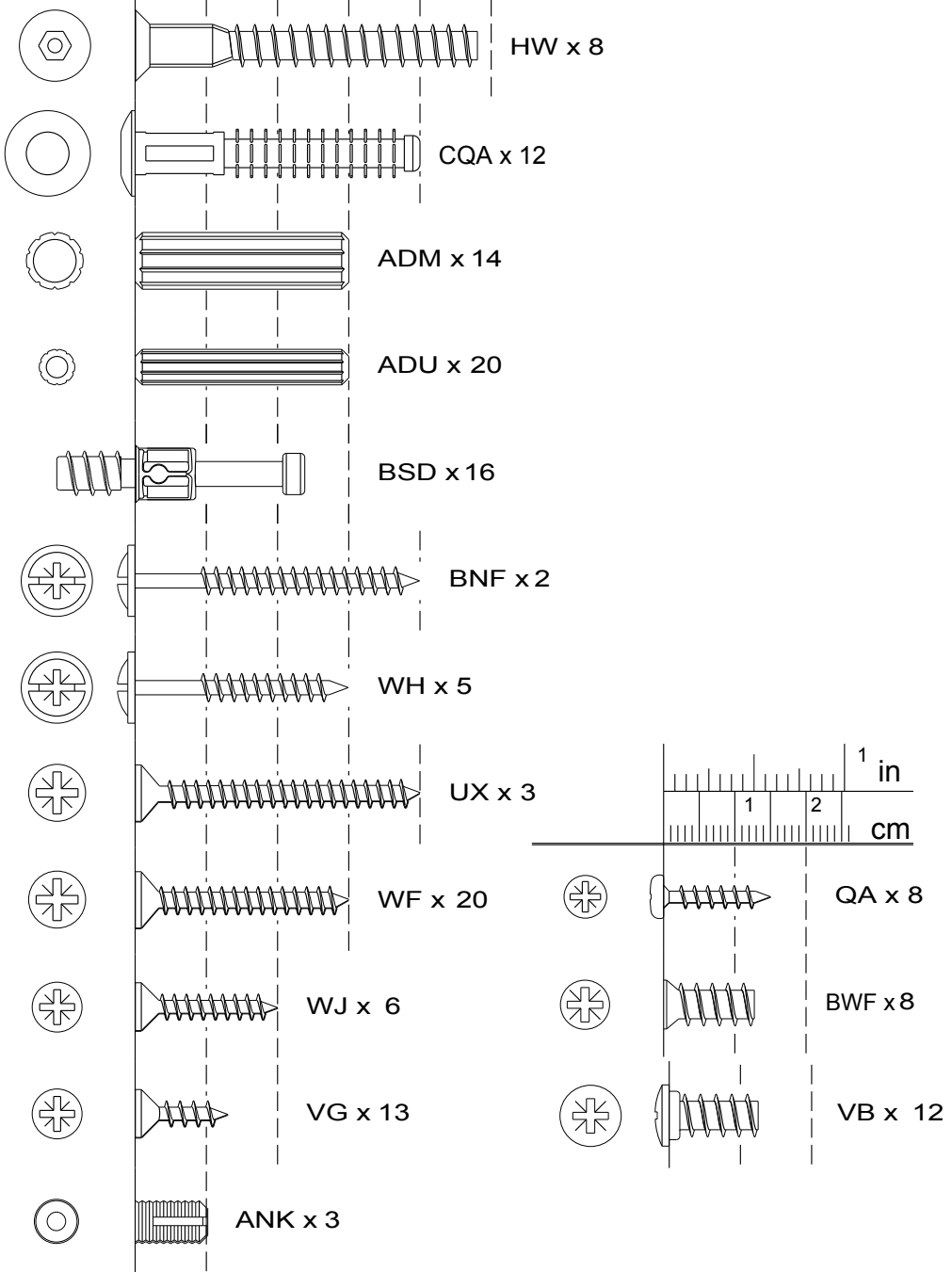
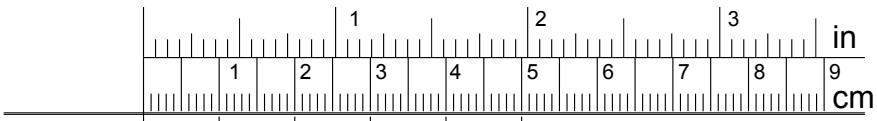

1

BSD x 8

ADU x 8

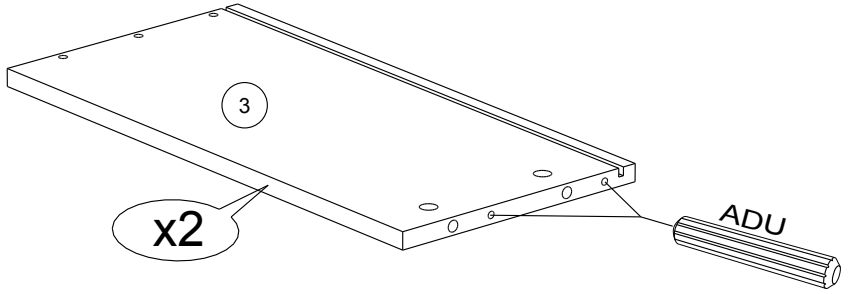
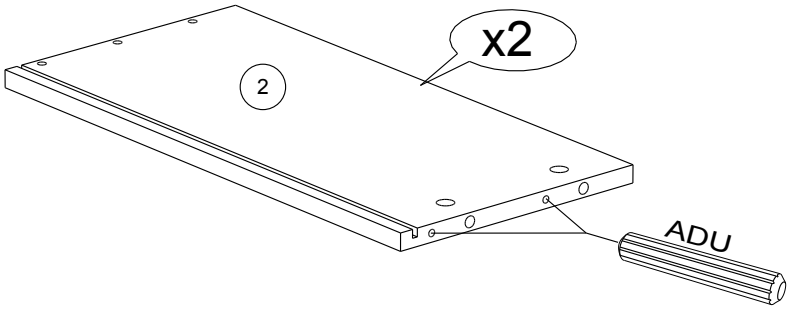
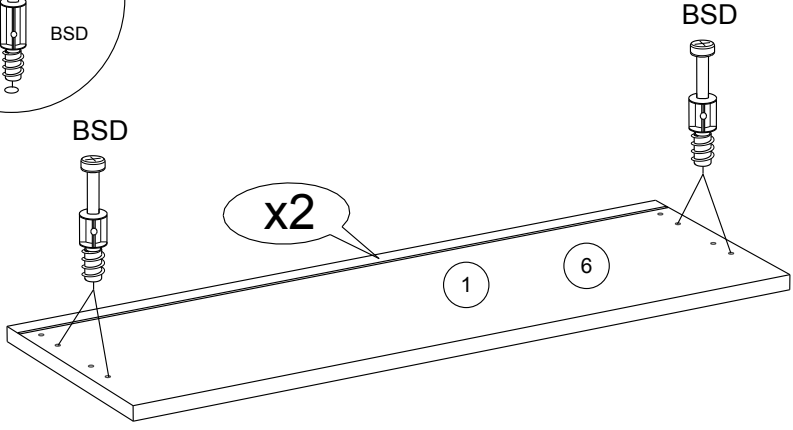
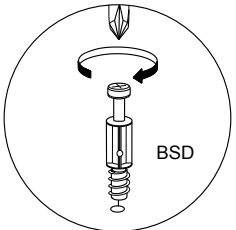
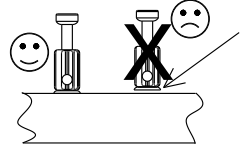

2



BZG x 8



CQA x 12

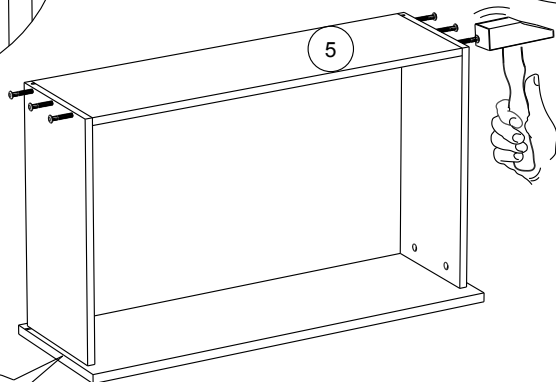
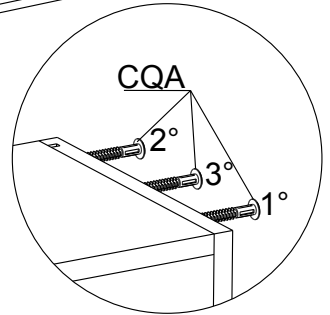
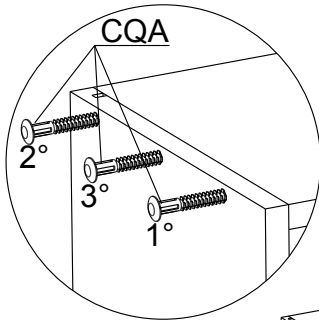
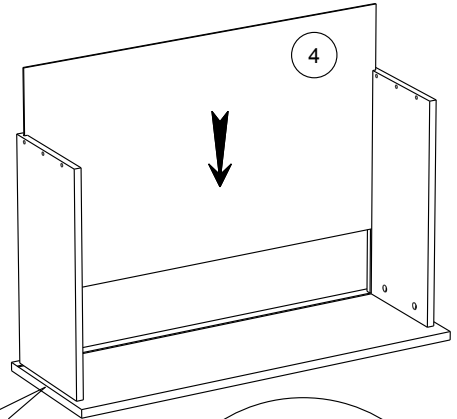
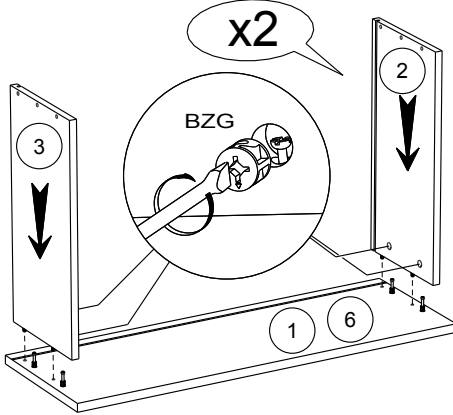

3

BSD x 6

BLL x 1

VG x 1

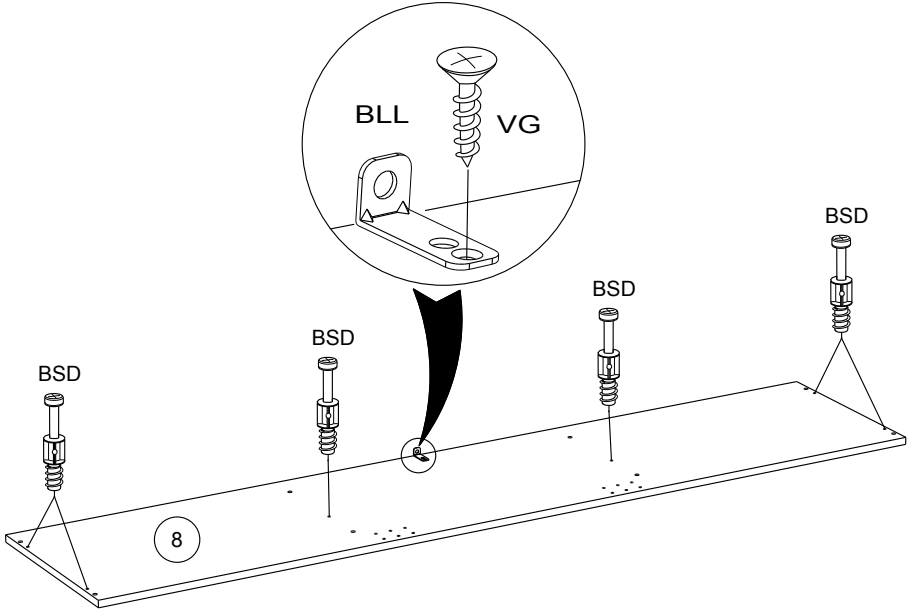

4

ANK x 3

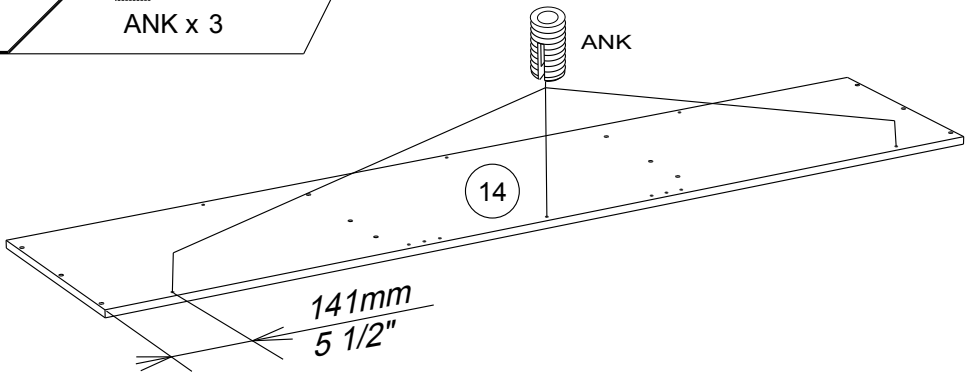

5



AFG x1



BWF x 2



VG x 1

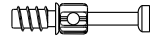

BSD x 1



ADM x 3

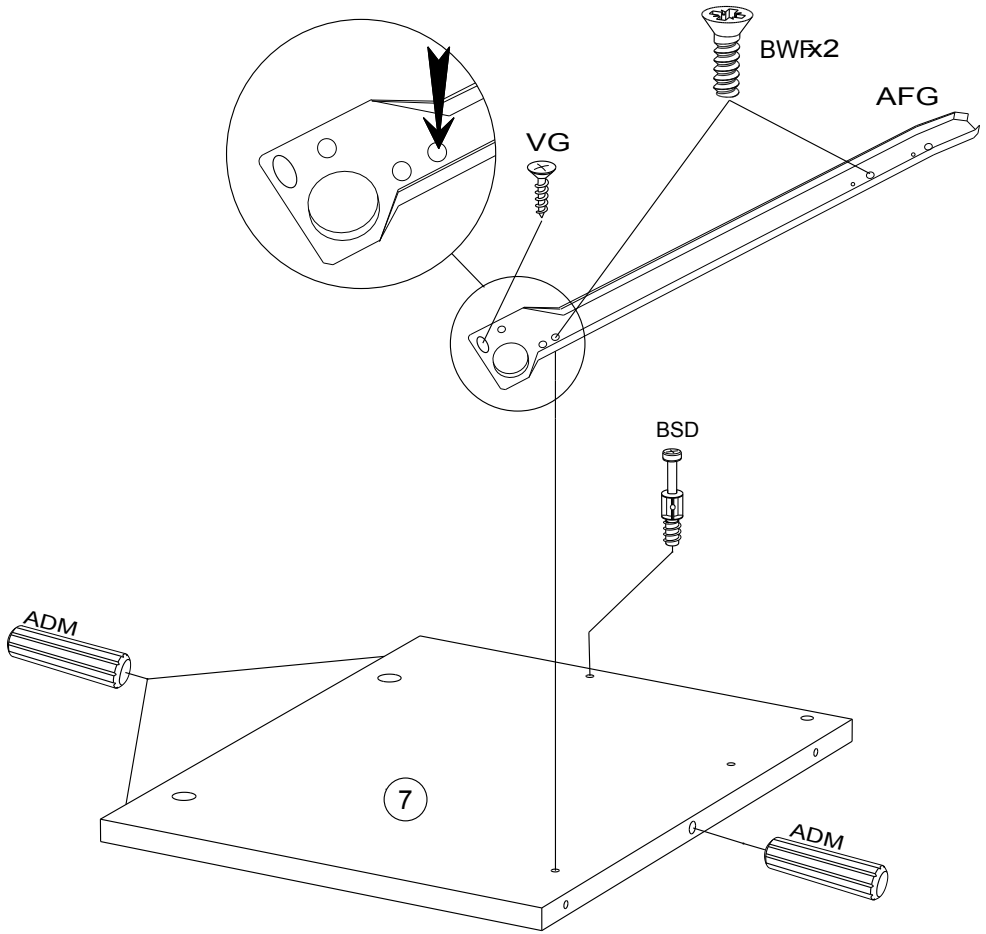

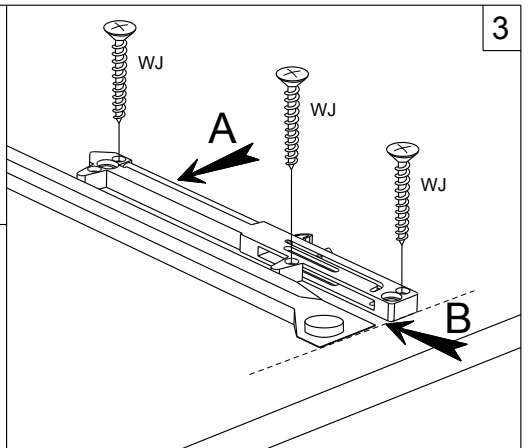
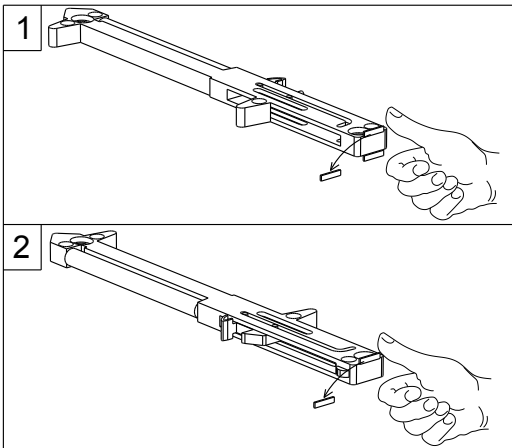
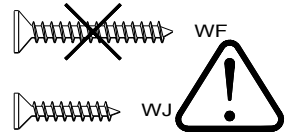
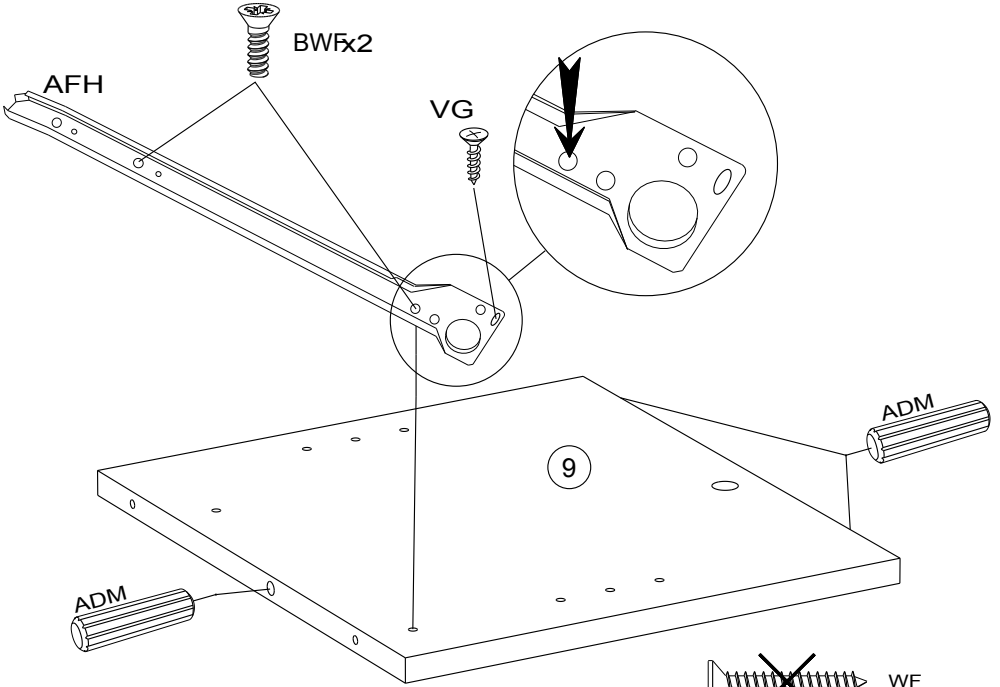
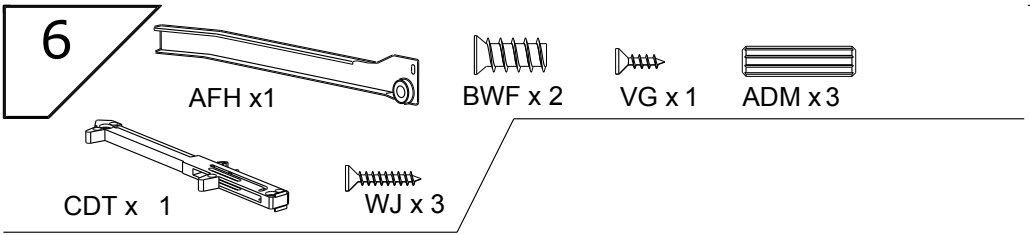

7



AFG x1



BWF x2



VG x1



ADM x3

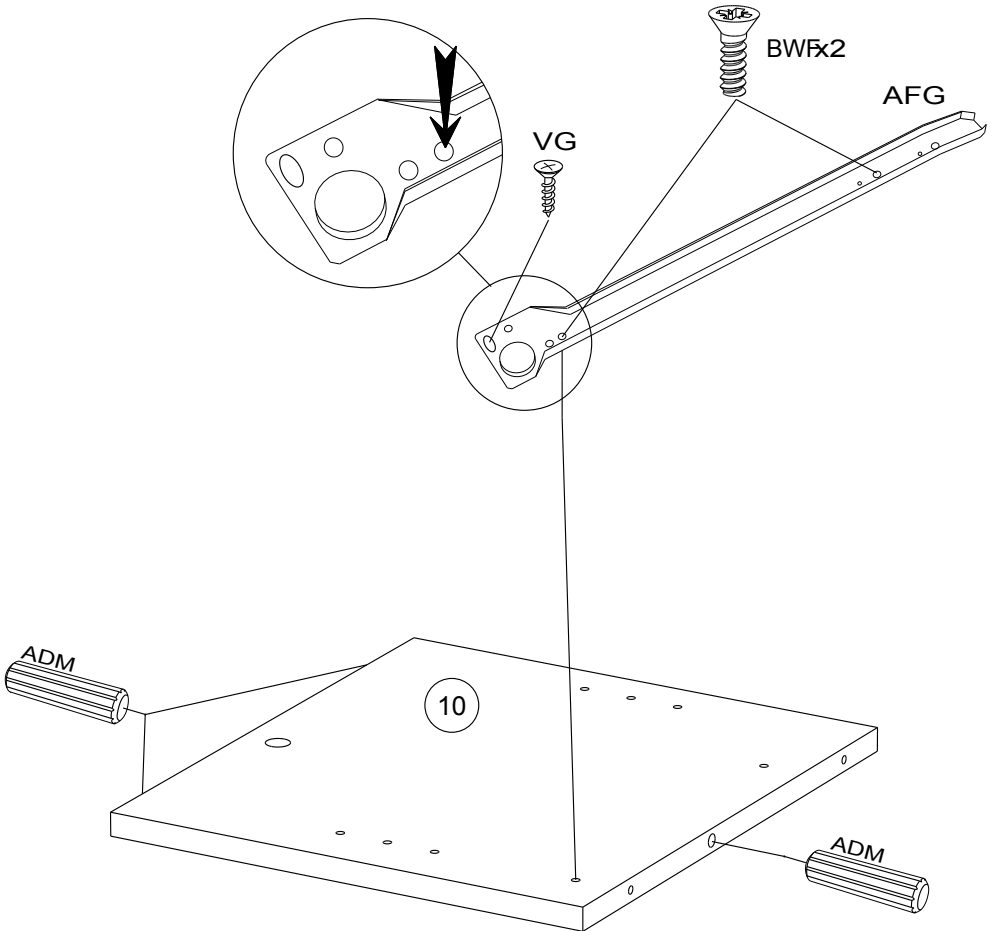

8

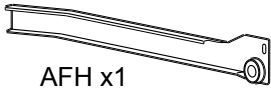

AFH x1



BWF x2



VG x1



ADM x3



BSD x1

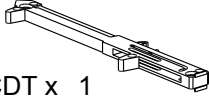

CDT x 1



WJ x 3

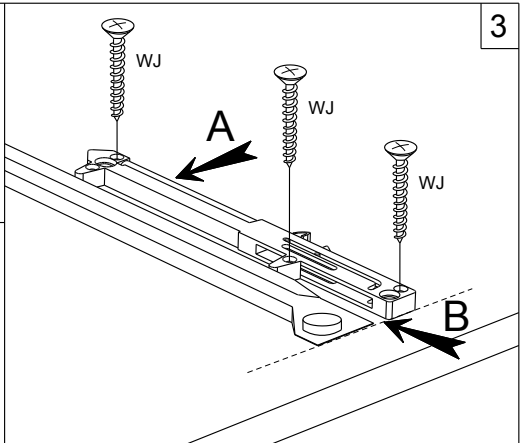
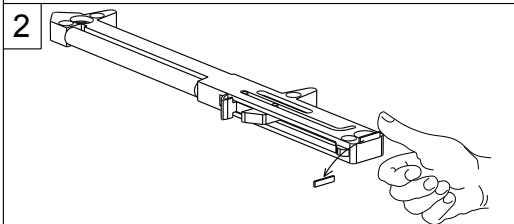
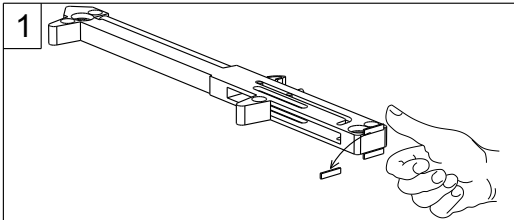
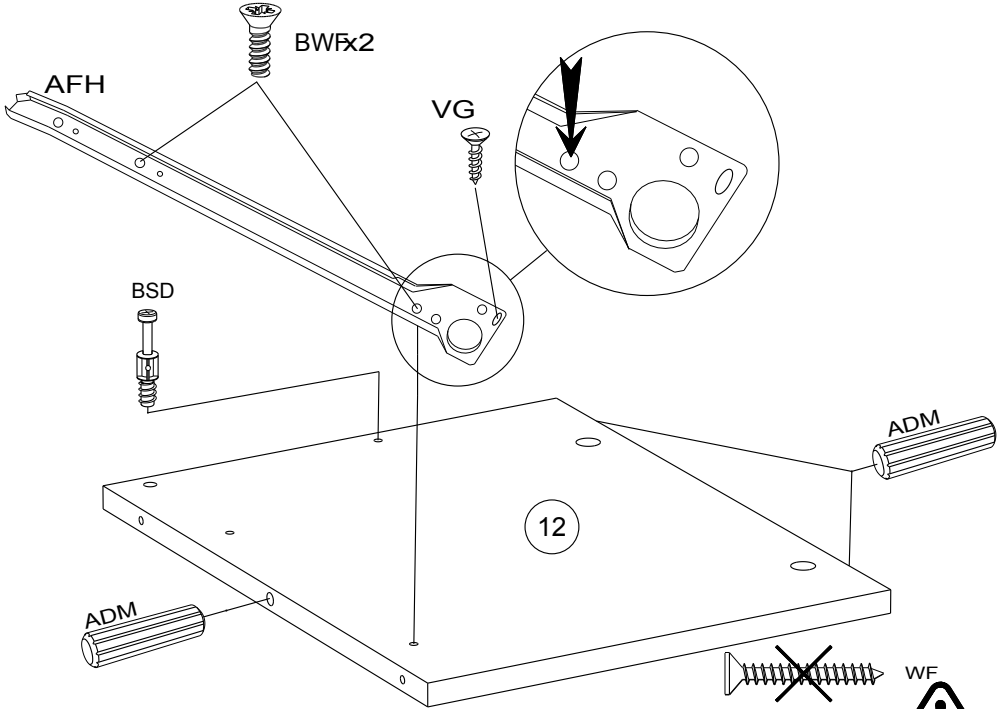

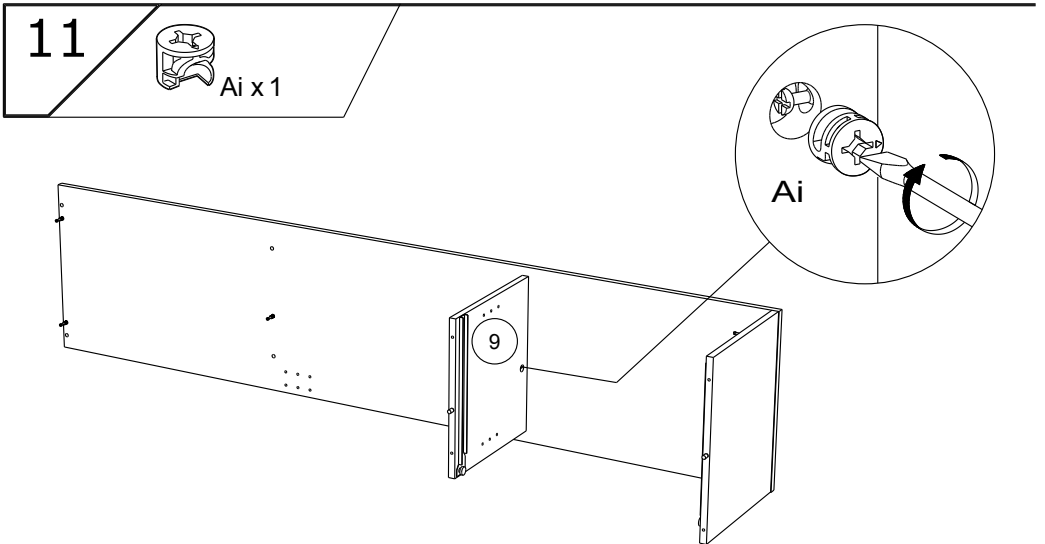
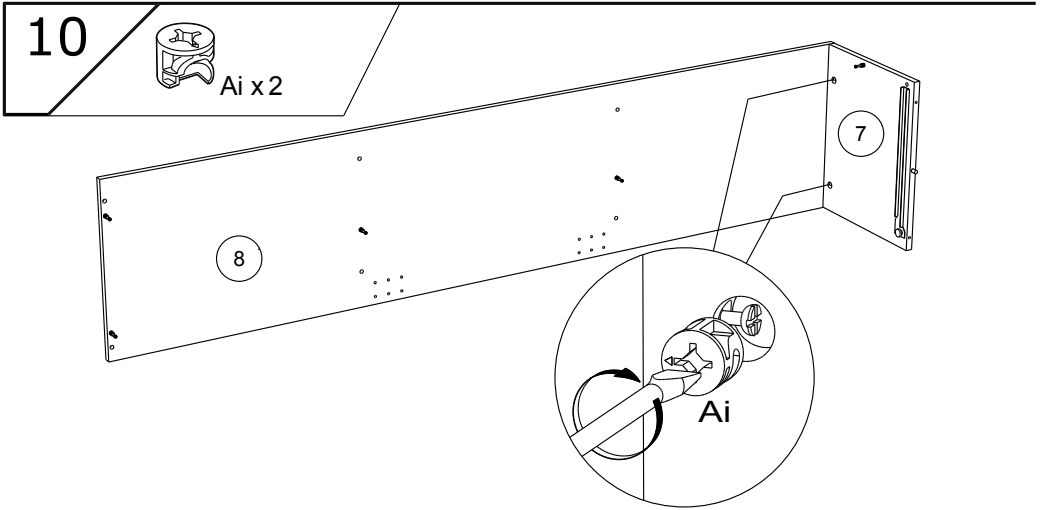
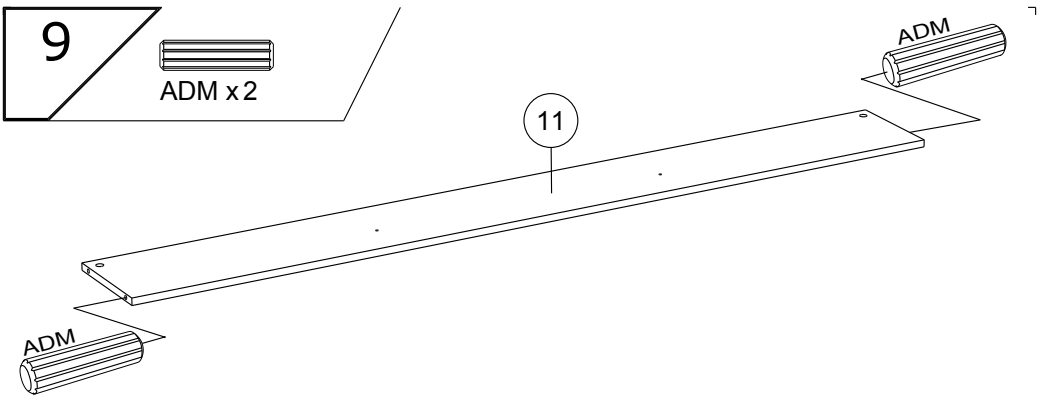

12



Ai x 1

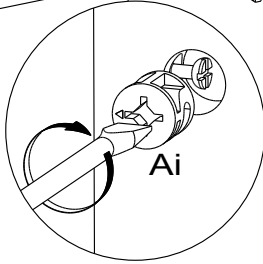
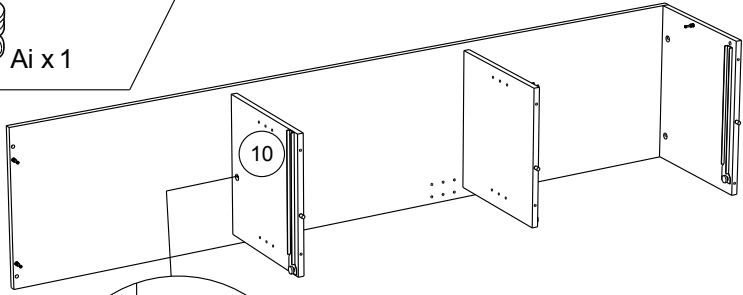

13

11

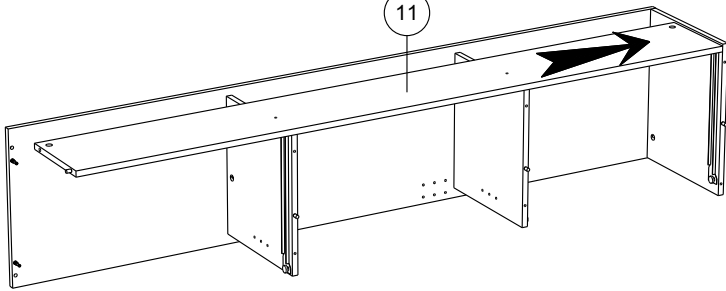

14

12

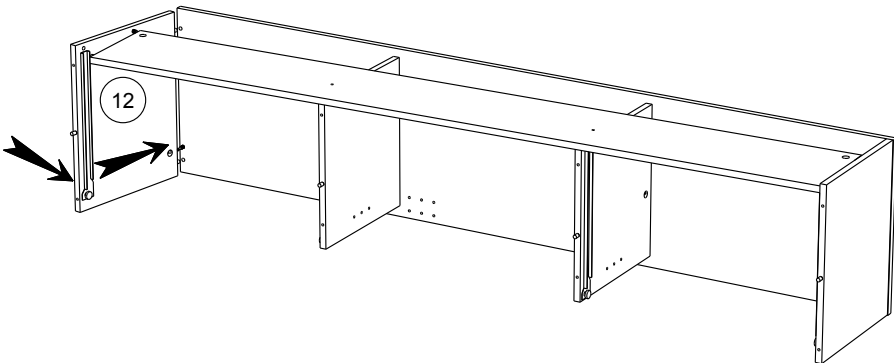

15



Ai x4

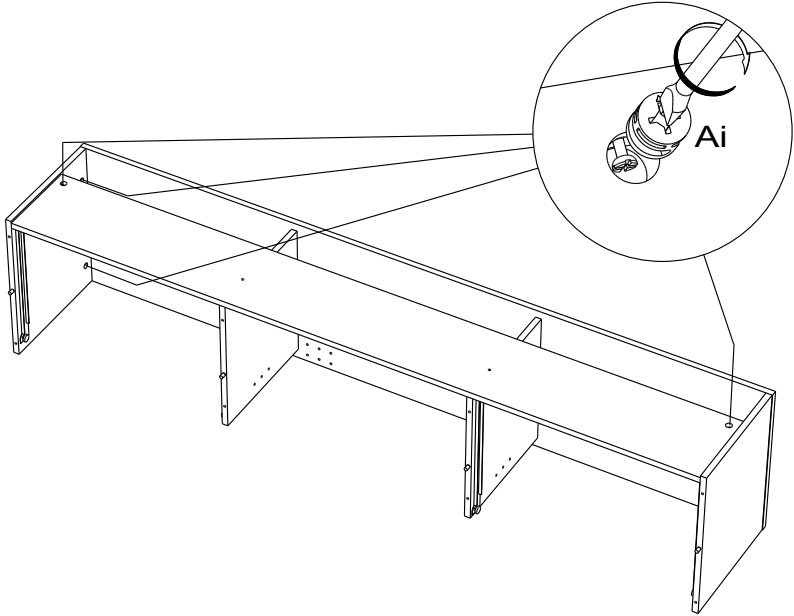

16

ADU x12

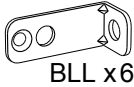

BLL x6



VB x 6

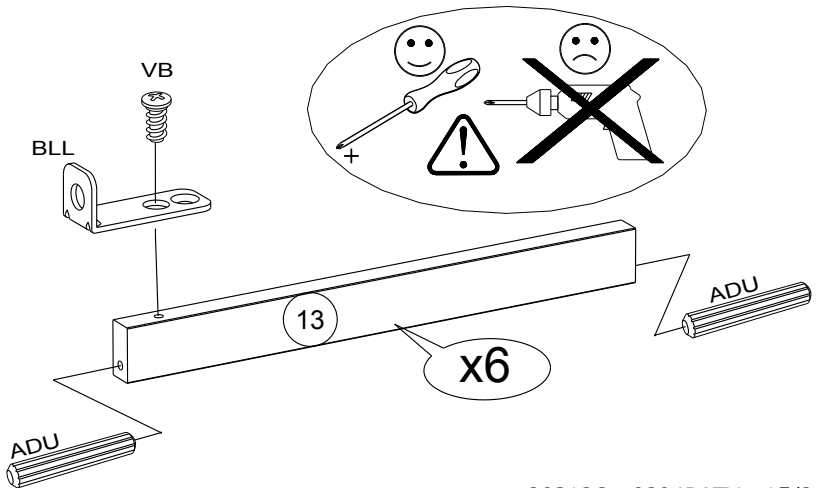

17



VB x 6

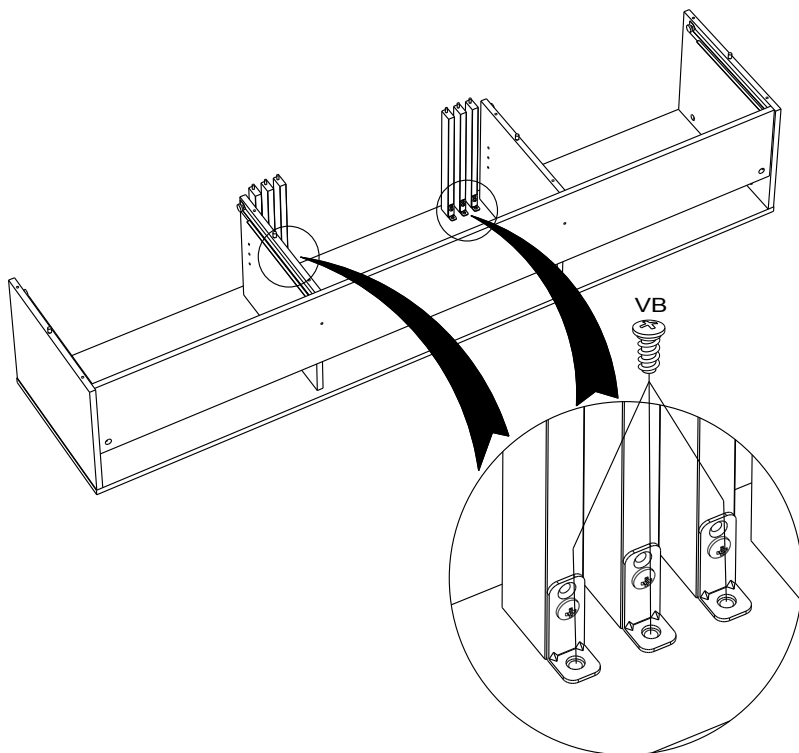
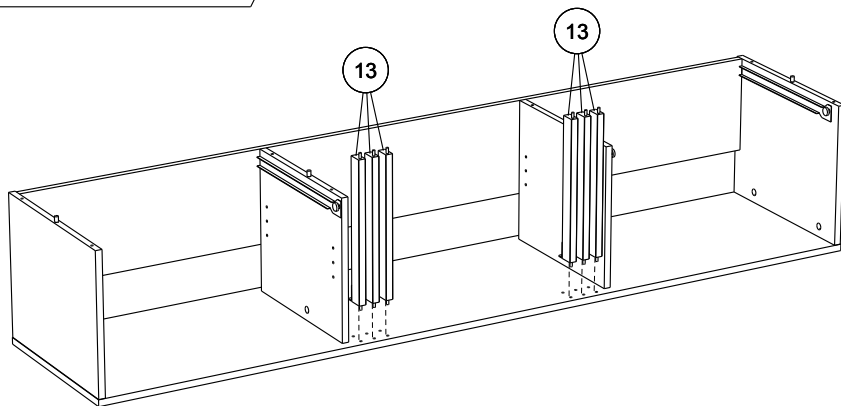

18

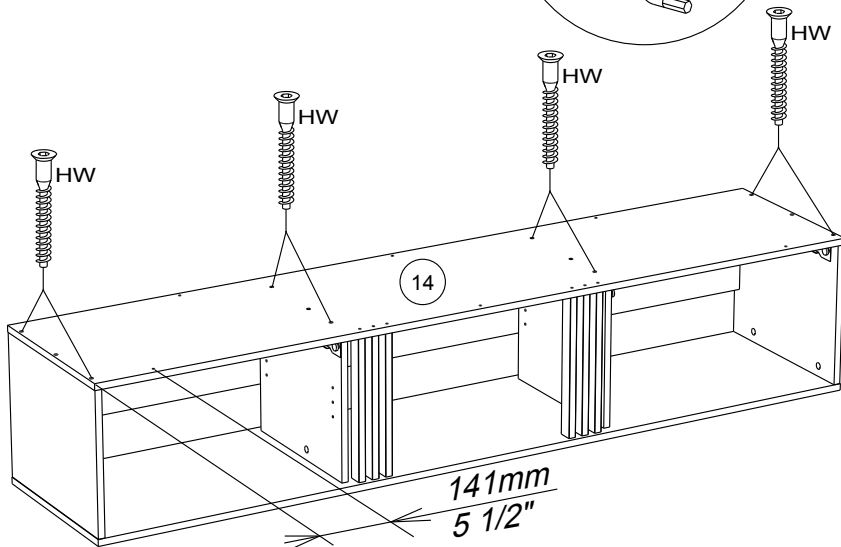
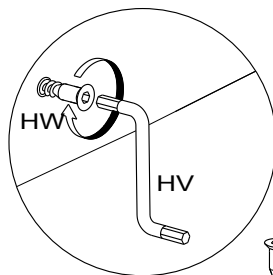
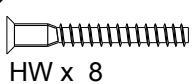

19

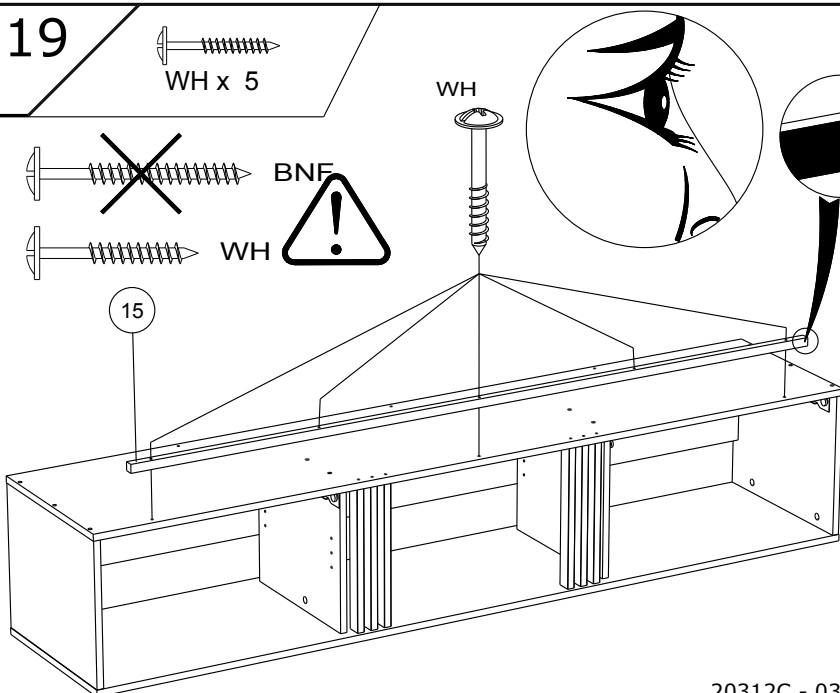
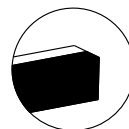
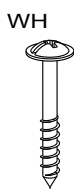
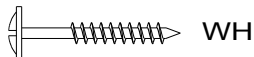
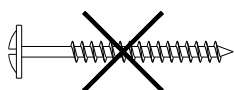
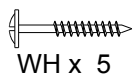

20

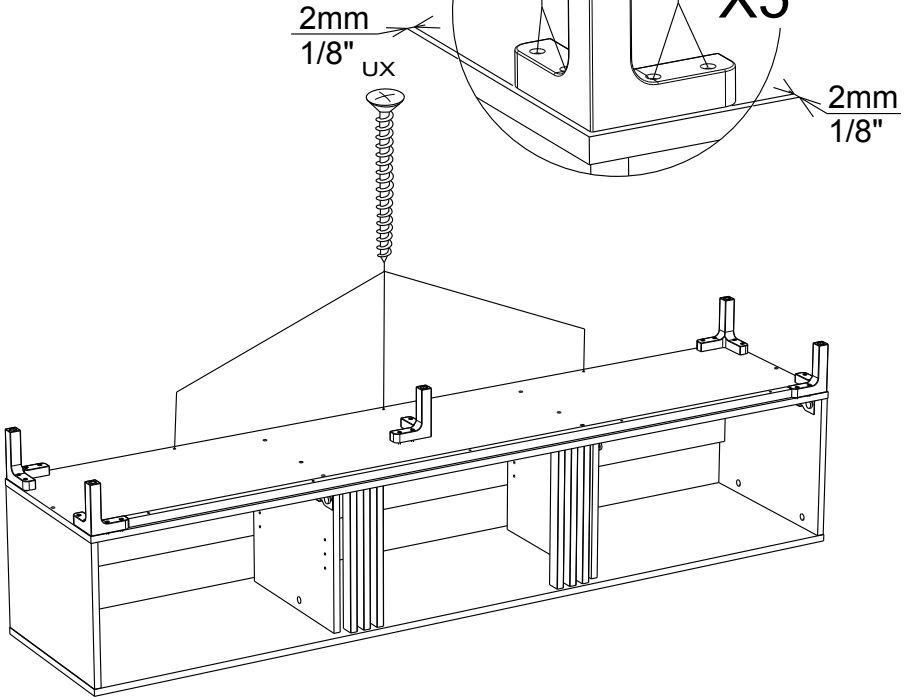
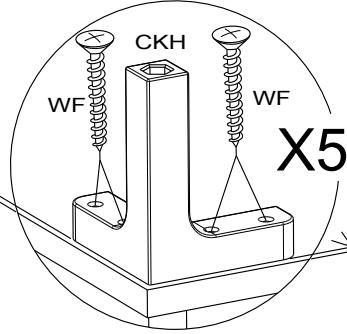
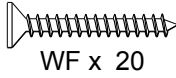
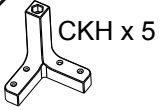
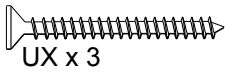

21

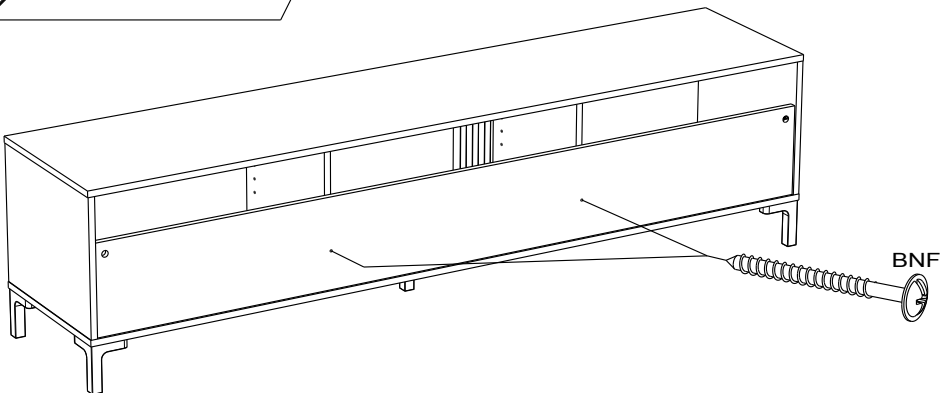

22

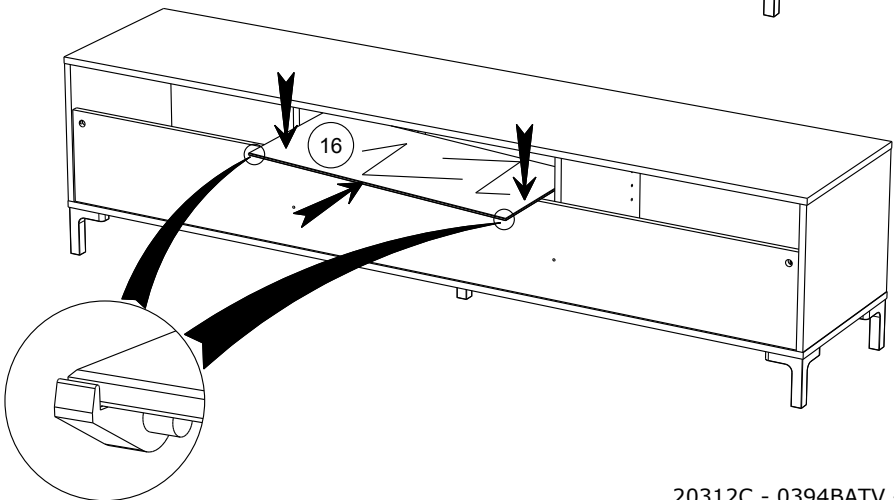
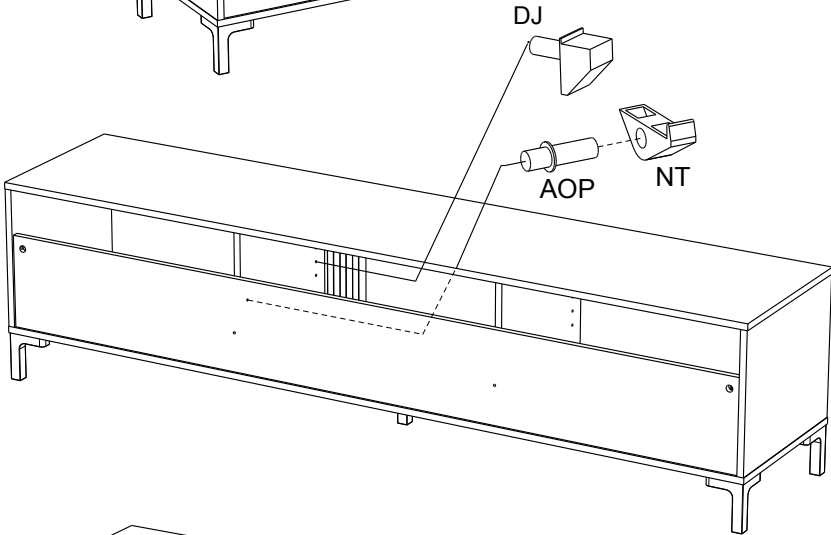
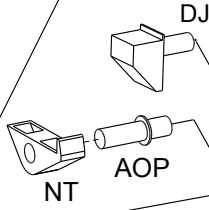

- FR** Pour votre sécurité : Fixation du meuble au mur.
Attention, la fixation doit être réalisée par une personne compétente car cela nécessite des chevilles adaptées à la nature de votre mur.
- EN** For your safety: Due to risk of overturning, this product must be used with the wall attachment device provided, this should be carried out by a competent person.
- DE** Zu Ihrer Sicherheit: Befestigen Sie das Möbel an der Wand.
Achtung: Diese Befestigung ist durch eine fachlich kompetente Person vorzunehmen.
Hierfür sind für die Bauweise Ihrer Wand geeignete Dübel einzusetzen.
- ES** Por su seguridad: Fijar el mueble a la pared.
Advertencia: la fijación la ha de llevar a cabo por personal adecuado, ya que requiere el uso de tacos que se adapten al tipo de pared.
- PT** Para sua segurança: fixação do móvel ao muro.
Atenção: a fixação deverá ser efetuada por pessoa habilitada, visto que são necessárias cavilhas adaptadas ao tipo de parede.
- IT** Avvertenza di sicurezza: il fissaggio del mobile a parete deve essere realizzato da una persona competente, in quanto l'operazione richiede l'impiego di tasselli adatti alla natura del muro.
- NL** Voor uw veiligheid: bevestiging van het meubel aan de muur.
Opgelet de bevestiging moet worden uitgevoerd door een bekwaam persoon daar dit voor uw type muur geschikte pluggen vereist.
- CZ** Z bezpečnostních důvodů: upevněte nábytek do zdi.
Pozor, upevnění je třeba svěřit kompetentní osobě, neboť vyžaduje hmoždinky vhodné pro vaši zeď.
- HU** Az Ön biztonsága érdekében : a bútor falra rögzítése.
Figyelmeztetés : a rögzítés csak megfelelő szakképessítéssel rendelkező személy által végezhető el, mert a rögzítéshez a falnak megfelelő csavarokra van szükség.
- PL** Dla bezpieczeństwa: mocowanie mebla do ściany.
Uwaga, mocowanie musi zostać wykonane przez osobę kompetentną, ponieważ wymaga to zastosowania kołków dostosowanych do rodzaju ściany.
- RO** Pentru securitatea dumneavoastră: fixarea mobilierului de perete.
Atenție, fixarea trebuie să fie realizată de o persoană calificată, deoarece sunt necesare dispozitive de fixare adaptate caracteristicilor peretelui dumneavoastră
- RU** Для вашей безопасности: Крепление мебели к стене
Внимание! Крепление должно производиться опытным специалистом, т.к. для такой установки потребуются штифты, соответствующие типу вашей стены.
- SK** Z bezpečnostných dôvodov: nábytok upevnite k stene.
Dbajte na to, aby upevnenie vykonala kompetentná osoba, pretože pri upevňovaní sa vyžadujú kolíky vhodné do materiálu, z ktorého je stena vyrobená.
- SL** Za vašo varnost: Enota naj bo pritrjena na steno. Pozor: To naj stori kompetentna oseba, ker je potrebno uporabiti pravilni nosilec glede na vrsto stene ki jo uporabljate.
- TR** Güvenliğiniz için: Mobilyanın duvara sabitlenmesi
Dikkat, sabitleme işlemi uzman biri tarafından yapılmalıdır çünkü bu işlem için duvarınızın malzemesine uygun dübellerin kullanılması gerekmektedir
- EL** Για την ασφάλειά σας : στερέωση των επίπλων στον τοίχο.
Προσοχή, η στερέωση πρέπει να γίνεται από ικανό άτομο, καθώς απαιτούνται σφήνες προσαρμοσμένες στη φύση του τοίχου σας.

AR سلامتك الشخصية: تثبيت قطعة الأثاث على الحائط

تحذير، يجب أن يقوم شخص متخصص بعملية التثبيت على الحائط إذ أنها تتطلب اسفينا معينا يتوافق مع طبيعة الحائط نفسه.

ZH 为了您的安全：本产品必须靠墙安装。

NB 本产品必须由专业人士安装，且您必须使用符合您的墙壁类型的罗威纤维管。

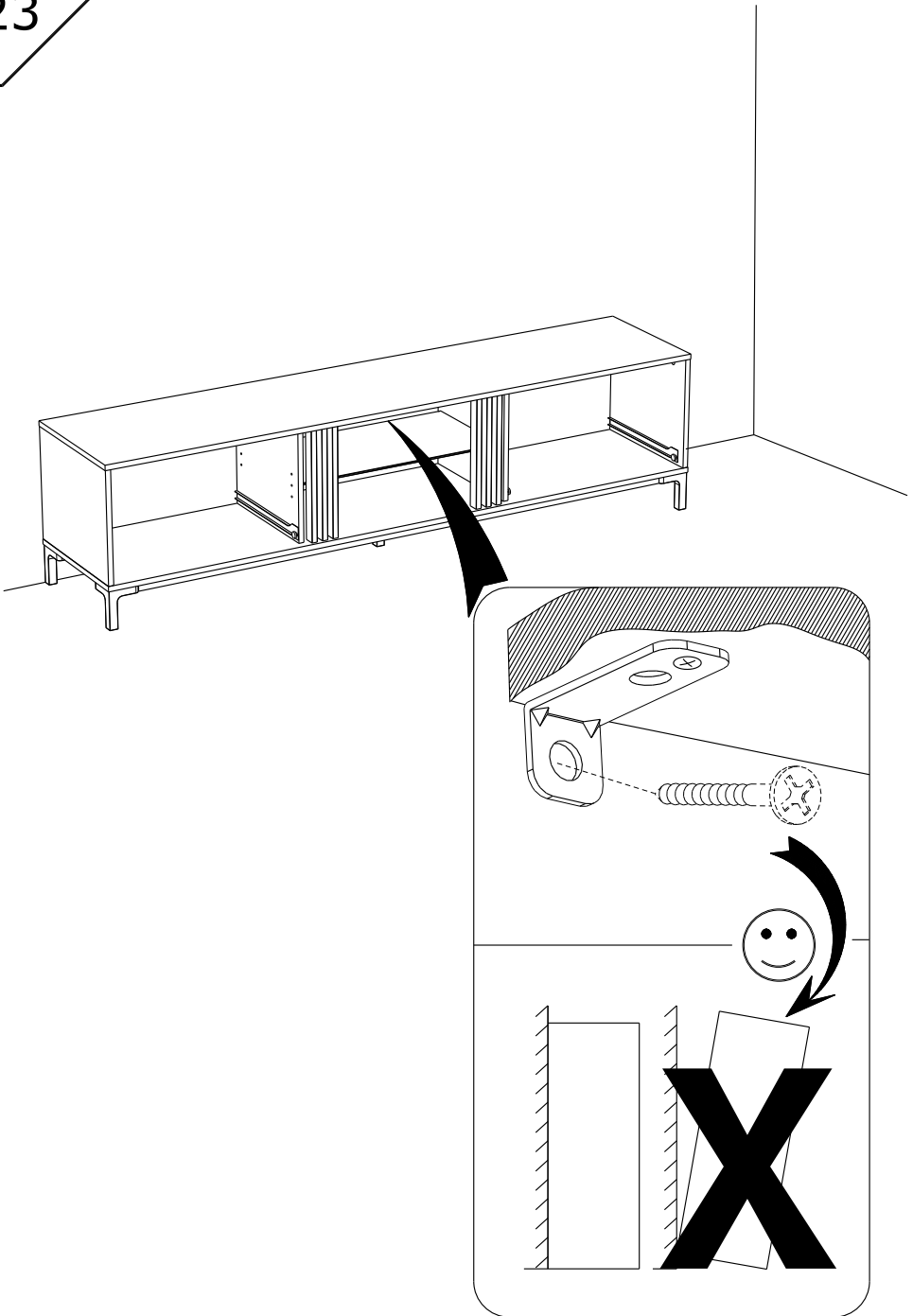

24



AFi x 2

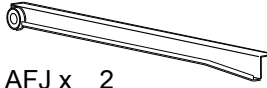

AFJ x 2

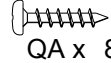

QA x 8



EP x2

x2

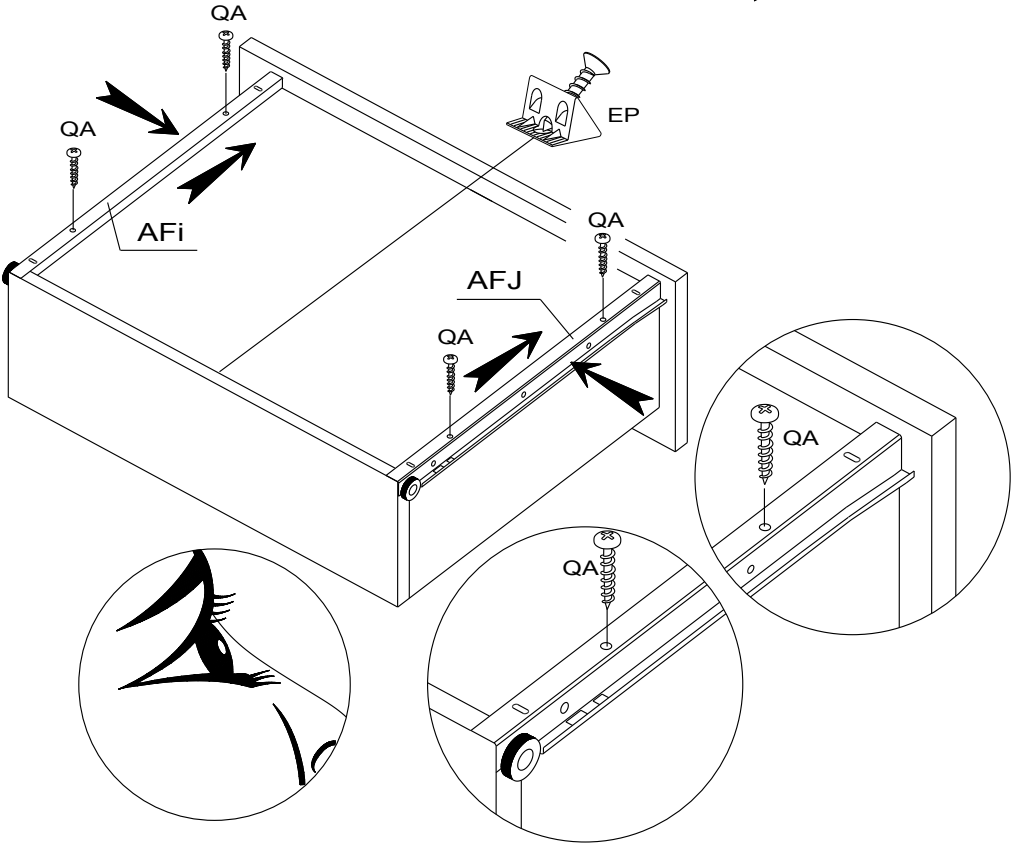

25

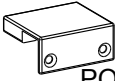

POi x 2



VG x 4

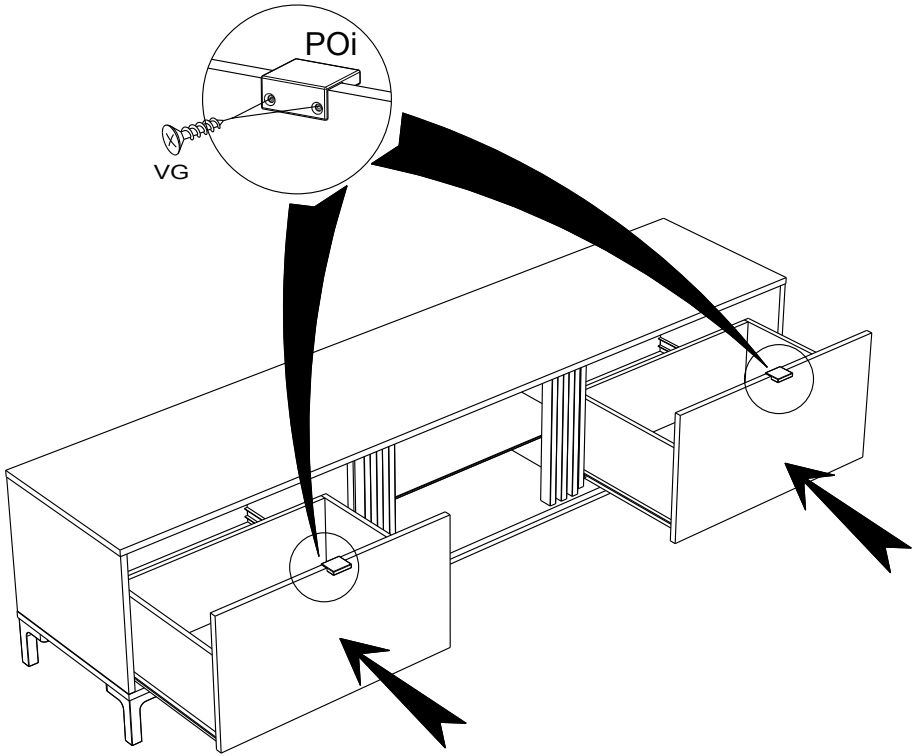

26

CDU x 2

VG x 4

