

2D Schuifdeur  
2P Portes coulissantes  
2D Sliding doors

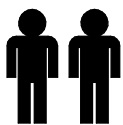

Opbouw met 2 personen  
Montage par 2 personnes  
Assembling by 2 persons

Gebruik deze handleiding van begin tot einde voor het probleemloos monteren van uw aangekocht meubel aub.

Veuillez bien suivre nos instructions ci-après lors du montage de votre meuble. Merci.

Please use the manual from the beginning until the end to assemble your newly bought furniture without troubles.

## Handleiding 1

### Manuel 1

### Manual 1

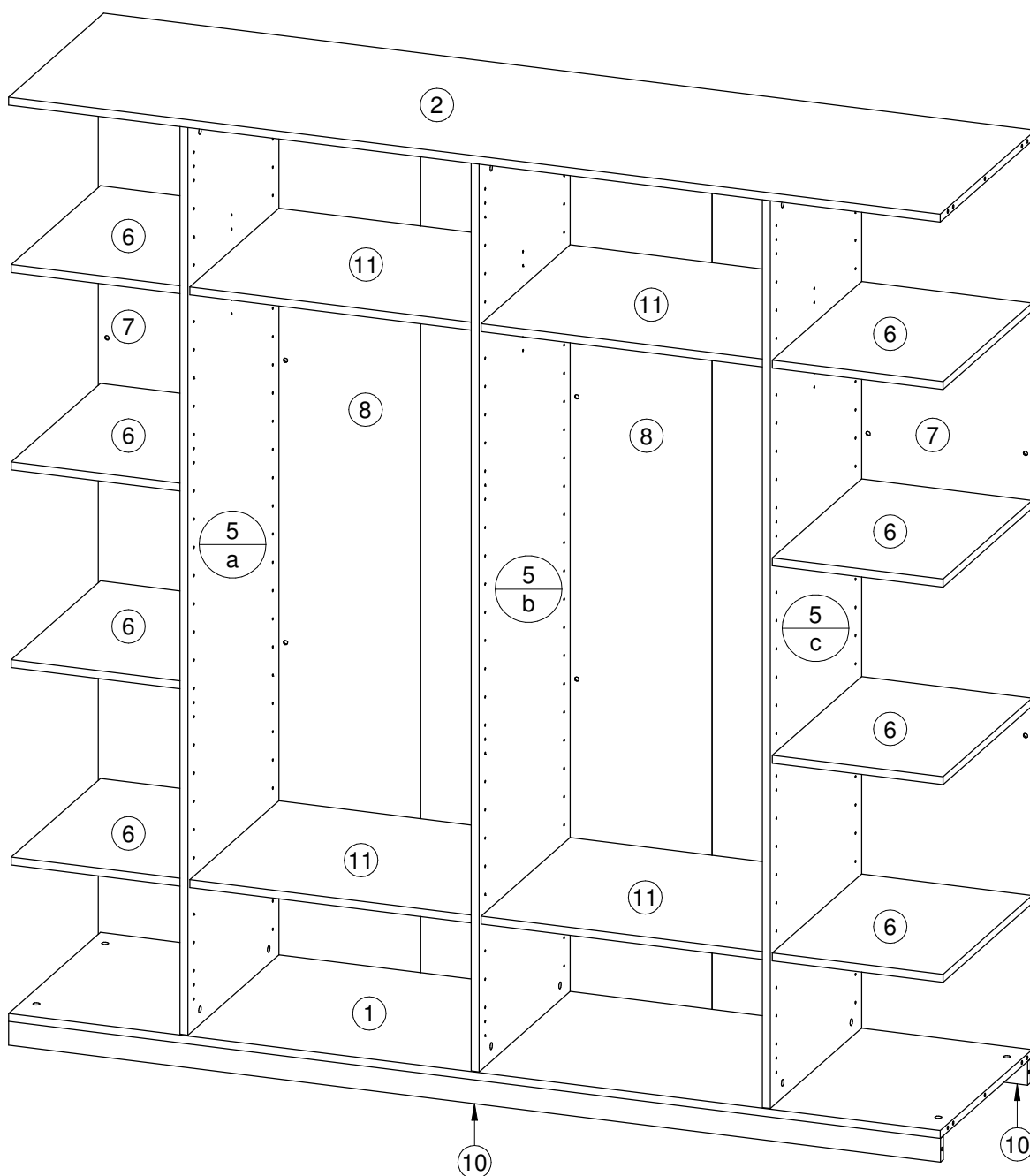
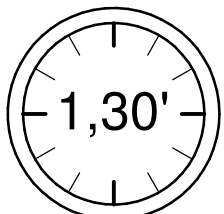
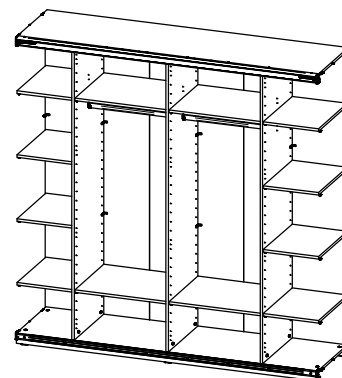

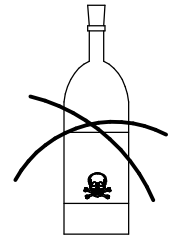
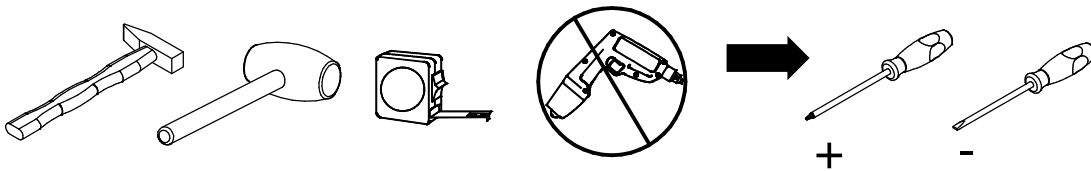

SOLVANT  
DILUANT  
OPLOSMIDDEL  
THINNER

**(FR)** Entretien: utilisez un chiffon légèrement humide et séchez aussitôt. Toute trace de liquide doit être enlevé immédiatement. Meuble inadapté aux pièces humides. N' utilisez jamais du solvant, détergent, diluant, produits chimiques ou cirage. Notice du montage à conserver. Pour tous service apres-vente, rendezvous au magasin avec cette notice.

**(GB)** Maintenance: clean with slightly wet moistened cloth, wipe dry immediately. Wipe off wetness at once. Not suited for humid locations. Never use solvent, cleaner, thinner, chemical products or wax. Retain manual instruction. For the after sales, go back to the shop with this assembly instruction.

**(NL)** Onderhoud: met licht vochtige doek reinigen hierna direct droog wrijven. Vocht op het bovenblad direct opnemen. De meubels zijn niet voor vochtige ruimten bestemd. Gebruik nooit oplosmiddel, reinigingsmiddel, verdunner, chemische producten of boenwas. Montage tekening opbergen. Voor service na verkoop, ga naar uw leverancier met deze montage handleiding.

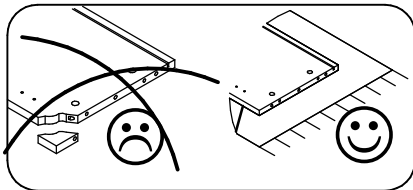

Made in Belgium

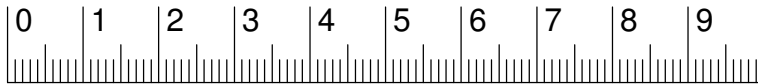
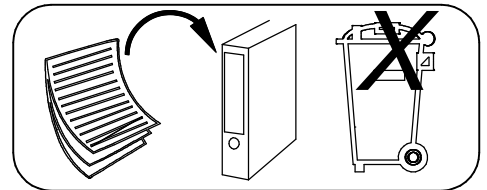

Beslagzak / sachet de quincaillerie / packet with fittings

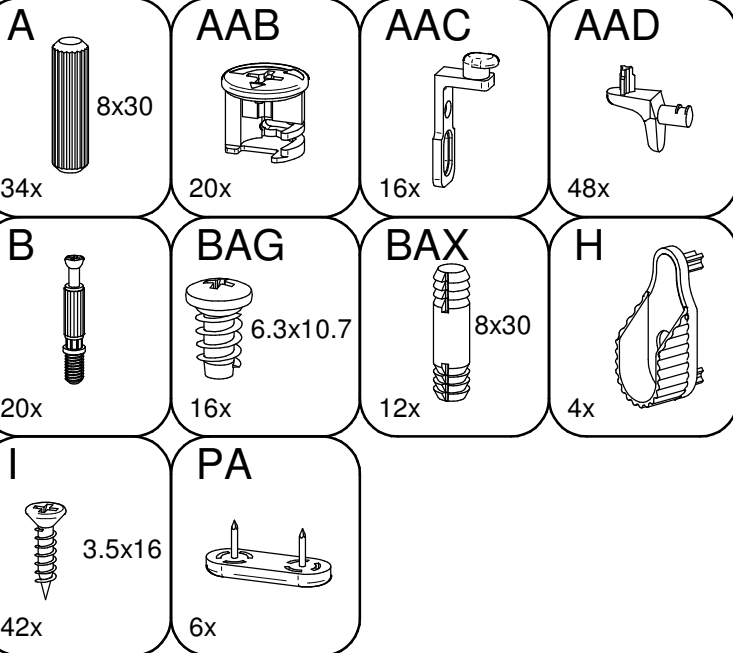

Doos 2 / boîte 2 / box 2

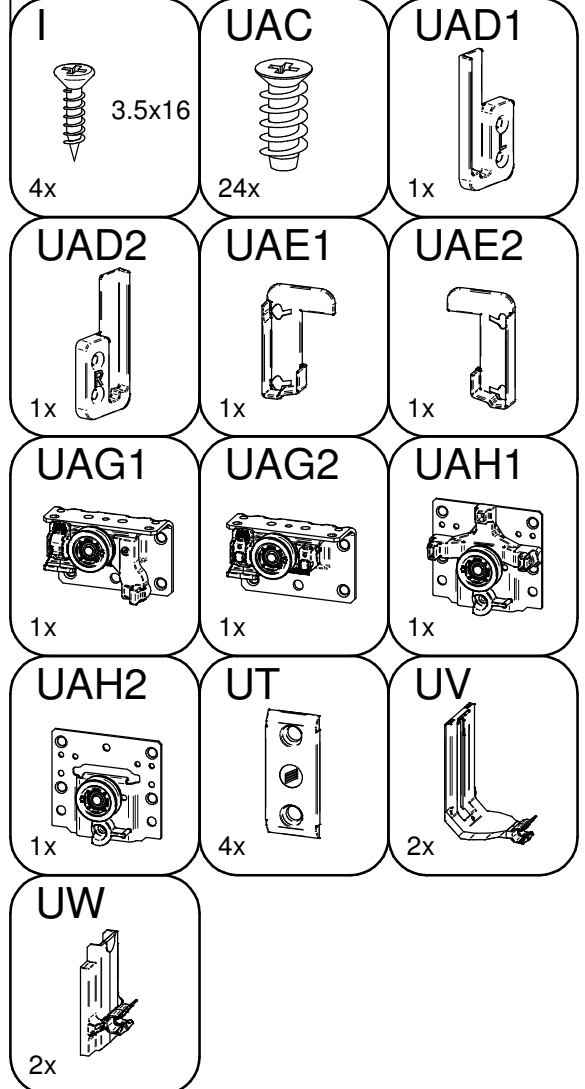

Doos 1 & 2 worden enkel gebruikt in handleiding 2 van het aangekochte meubel.

Boîte 1 & 2 sont seulement utilisées dans le manuel 2 du meuble acheté.

Box 1 & 2 are only used in manual 2 of the purchased furniture.

Doos 1 / boîte 1 / box 1

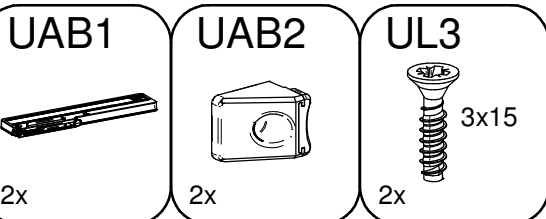

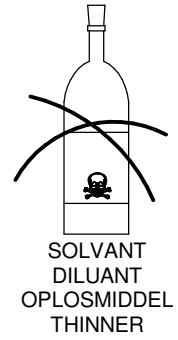
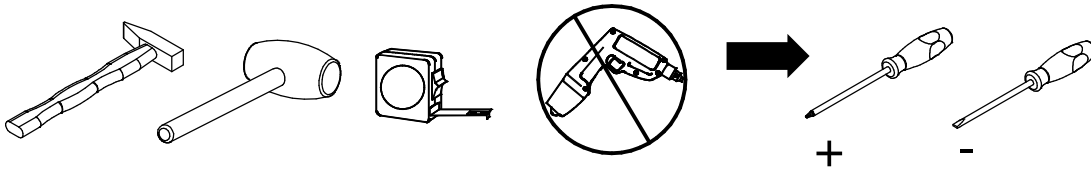

**(FR)** Entretien: utilisez un chiffon légèrement humide et séchez aussitôt. Toute trace de liquide doit être enlevé immédiatement. Meuble inadapté aux pièces humides. N' utilisez jamais du solvant, détergent, diluant, produits chimiques ou cirage. Notice du montage à conserver. Pour tous service apres-vente, rendezvous au magasin avec cette notice.

**(GB)** Maintenance: clean with slightly wet moistened cloth, wipe dry immediately. Wipe off wetness at once. Not suited for humid locations. Never use solvent, cleaner, thinner, chemical products or wax. Retain manual instruction. For the after sales, go back to the shop with this assembly instruction.

**(NL)** Onderhoud: met licht vochtige doek reinigen hierna direct droog wrijven. Vocht op het bovenblad direct opnemen. De meubels zijn niet voor vochtige ruimten bestemd. Gebruik nooit oplosmiddel, reinigingsmiddel, verdunner, chemische producten of boenwas. Montage tekening opbergen. Voor service na verkoop, ga naar uw leverancier met deze montage handleiding.

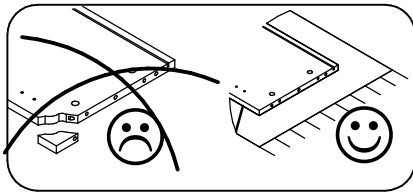

Made in Belgium

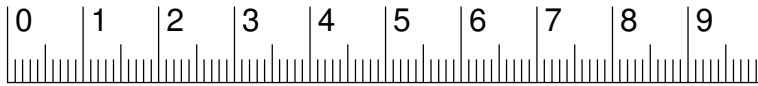
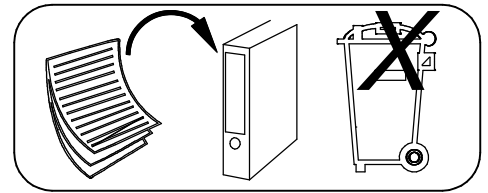

Afhankelijk van de kastbreedte (enkel nodig in handleiding 2):

Dépendant de largeur de l'armoire (seulement besoin à manuel 2):

Depends on the width of the cabinet (only needed in manual 2):

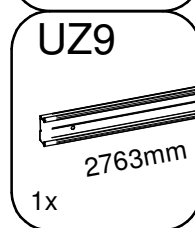
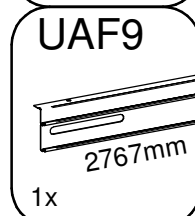
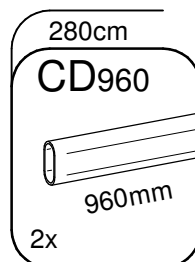
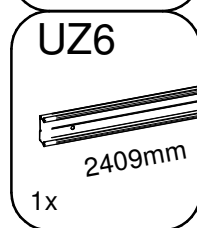
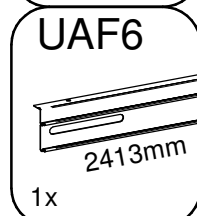
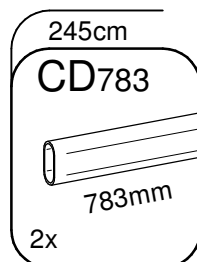
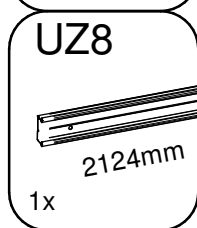
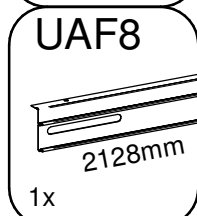
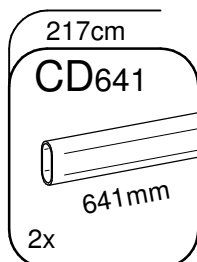

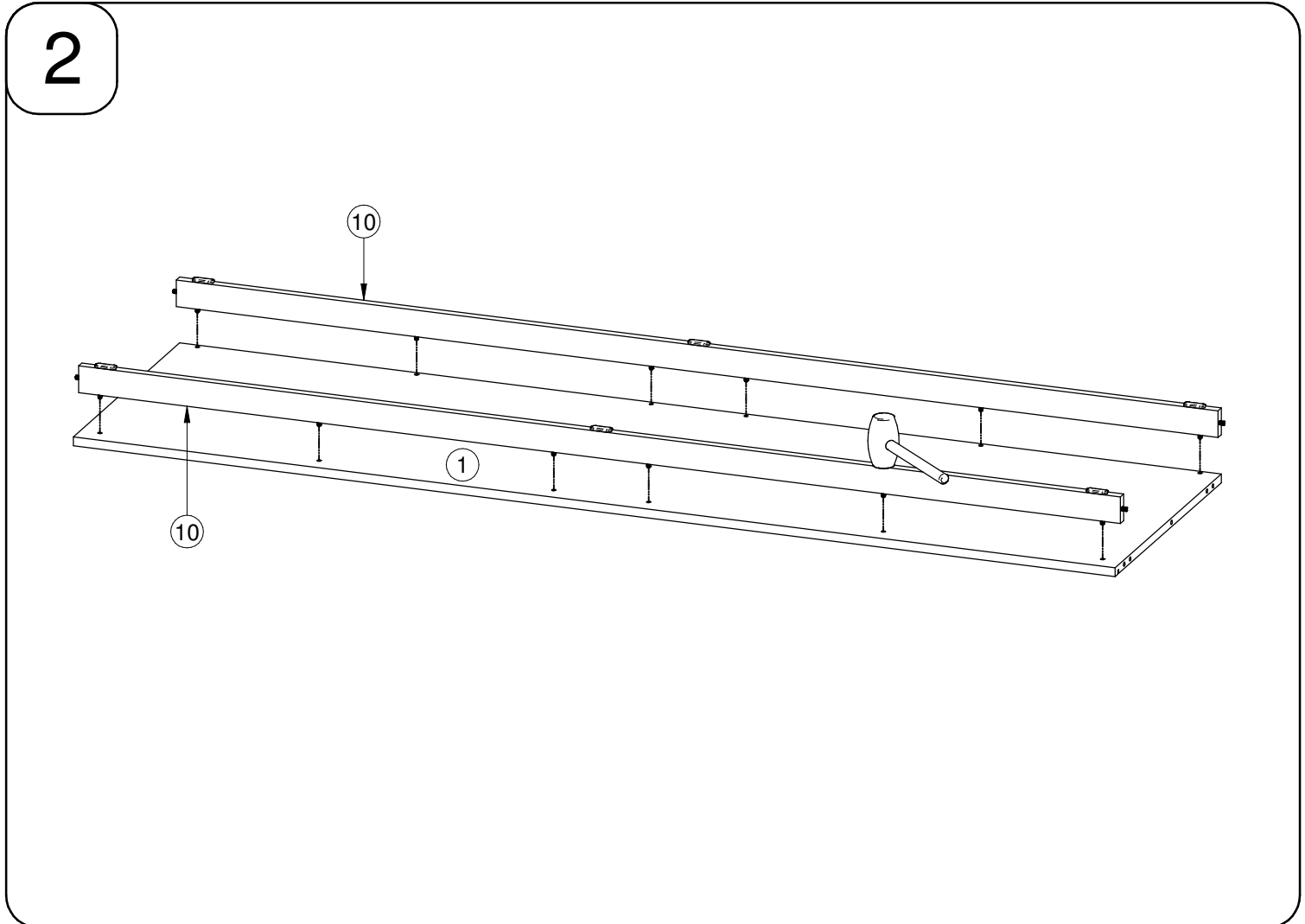
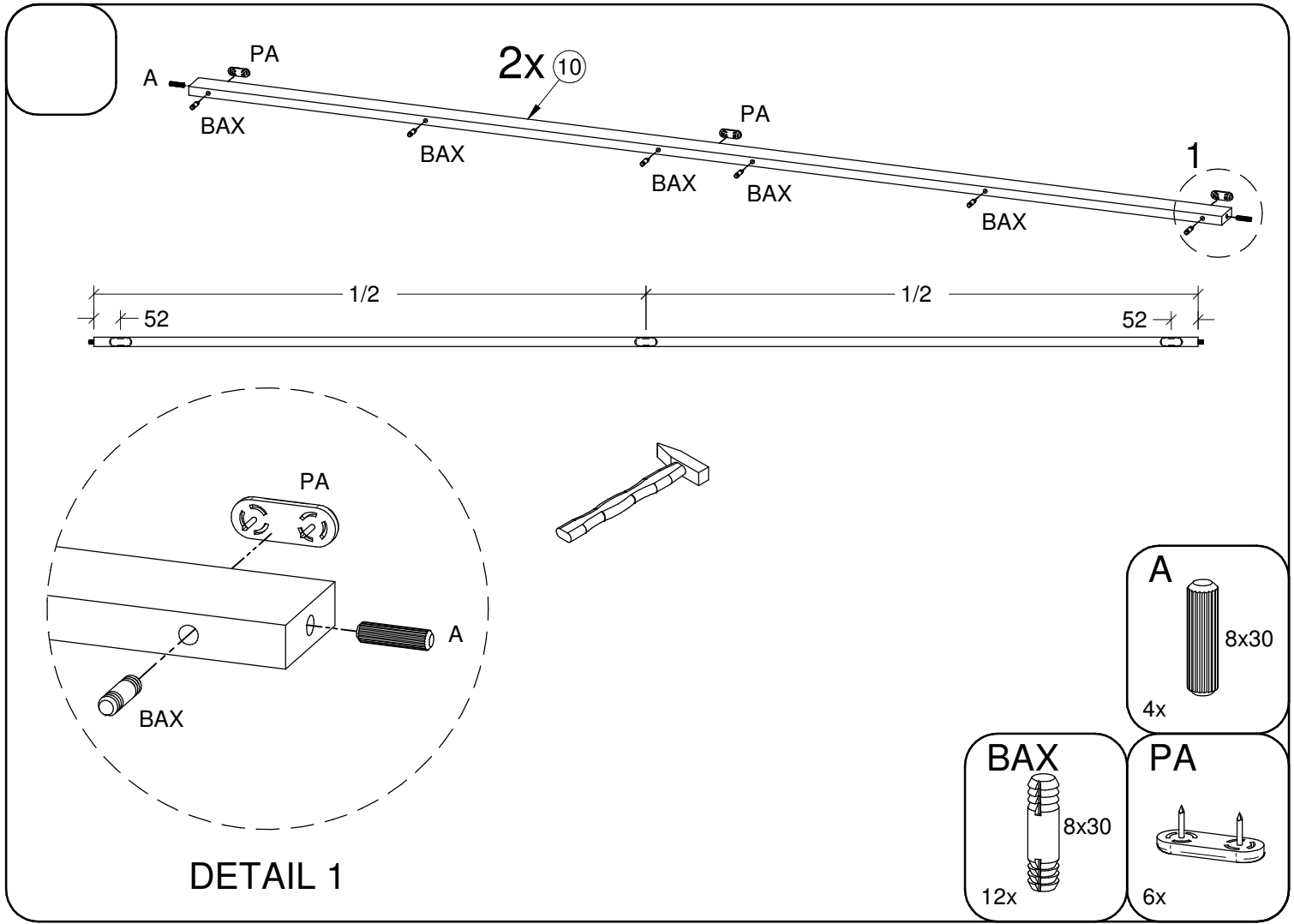

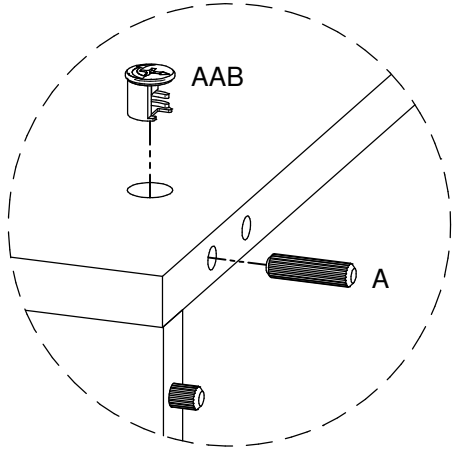
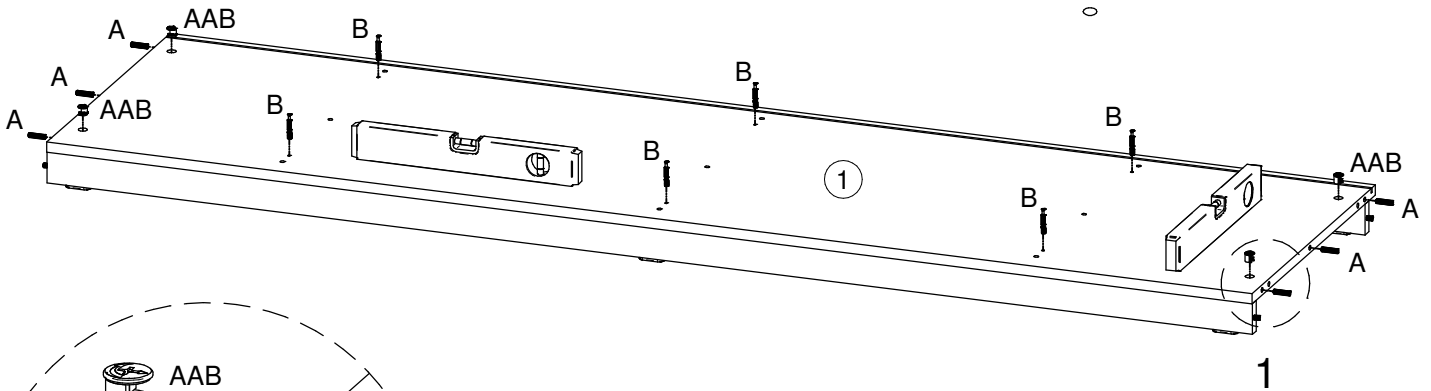
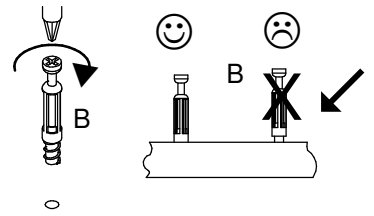
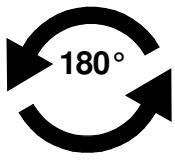

DETAIL 1

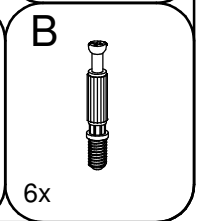
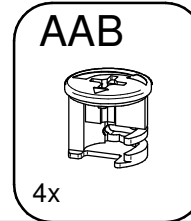
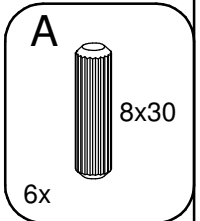

4

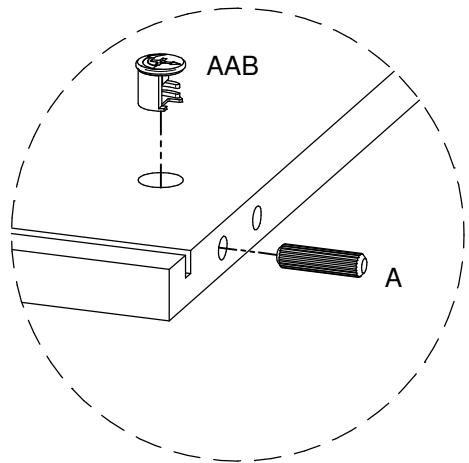
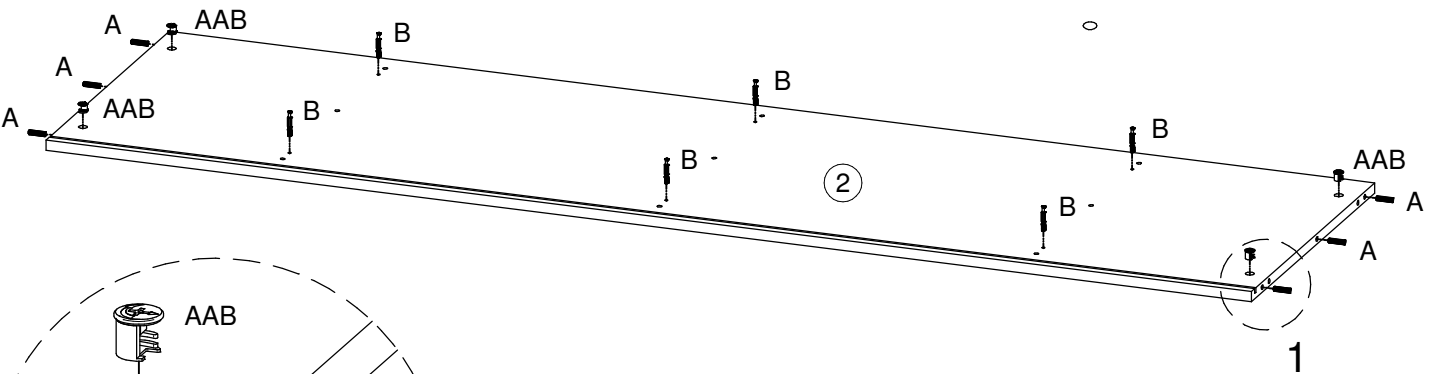
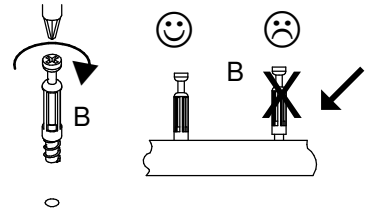

DETAIL 1

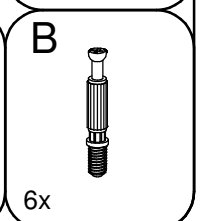
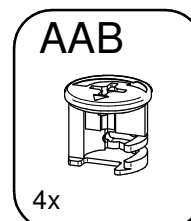
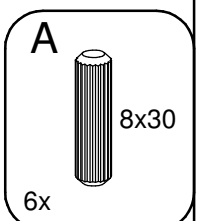

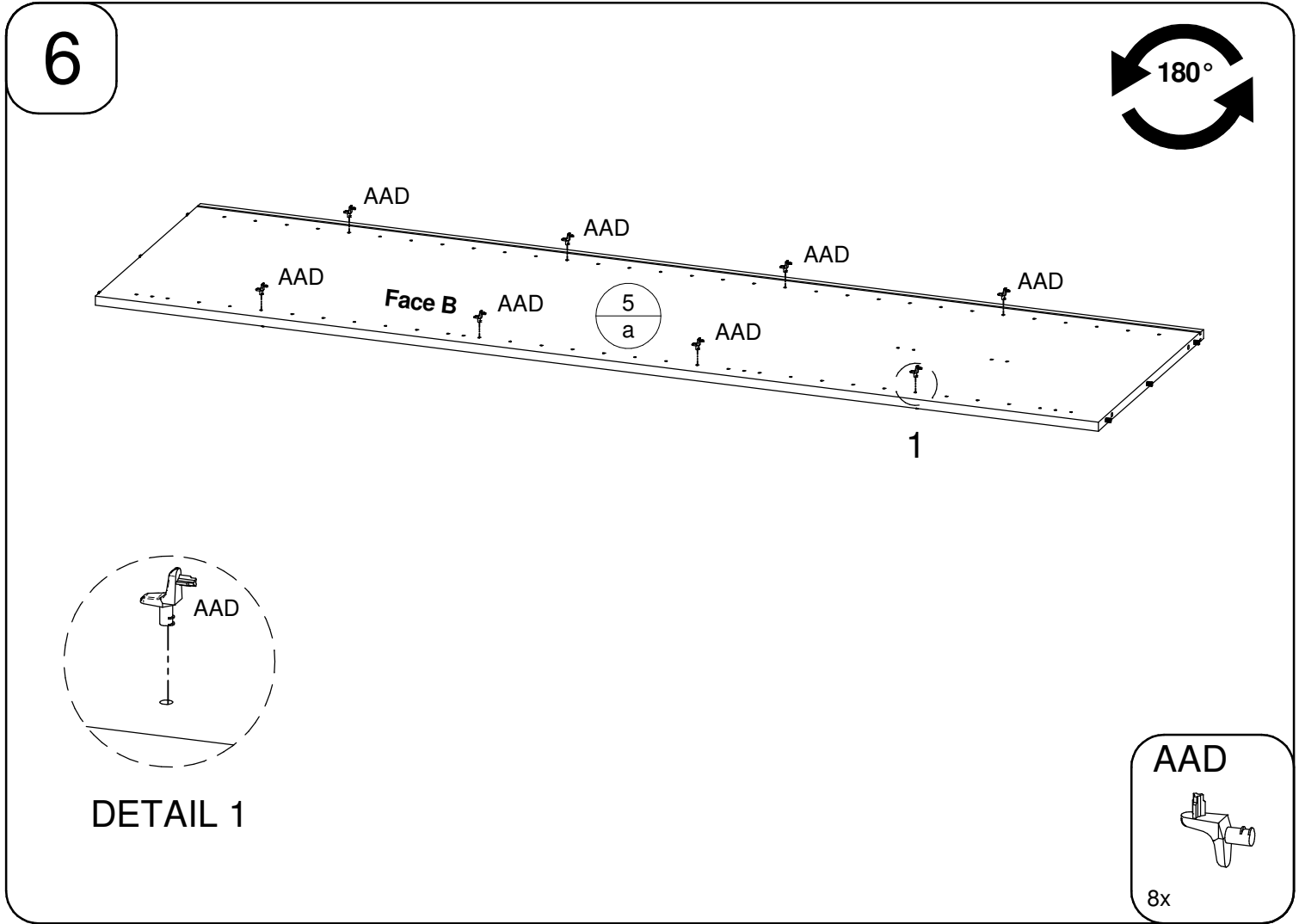
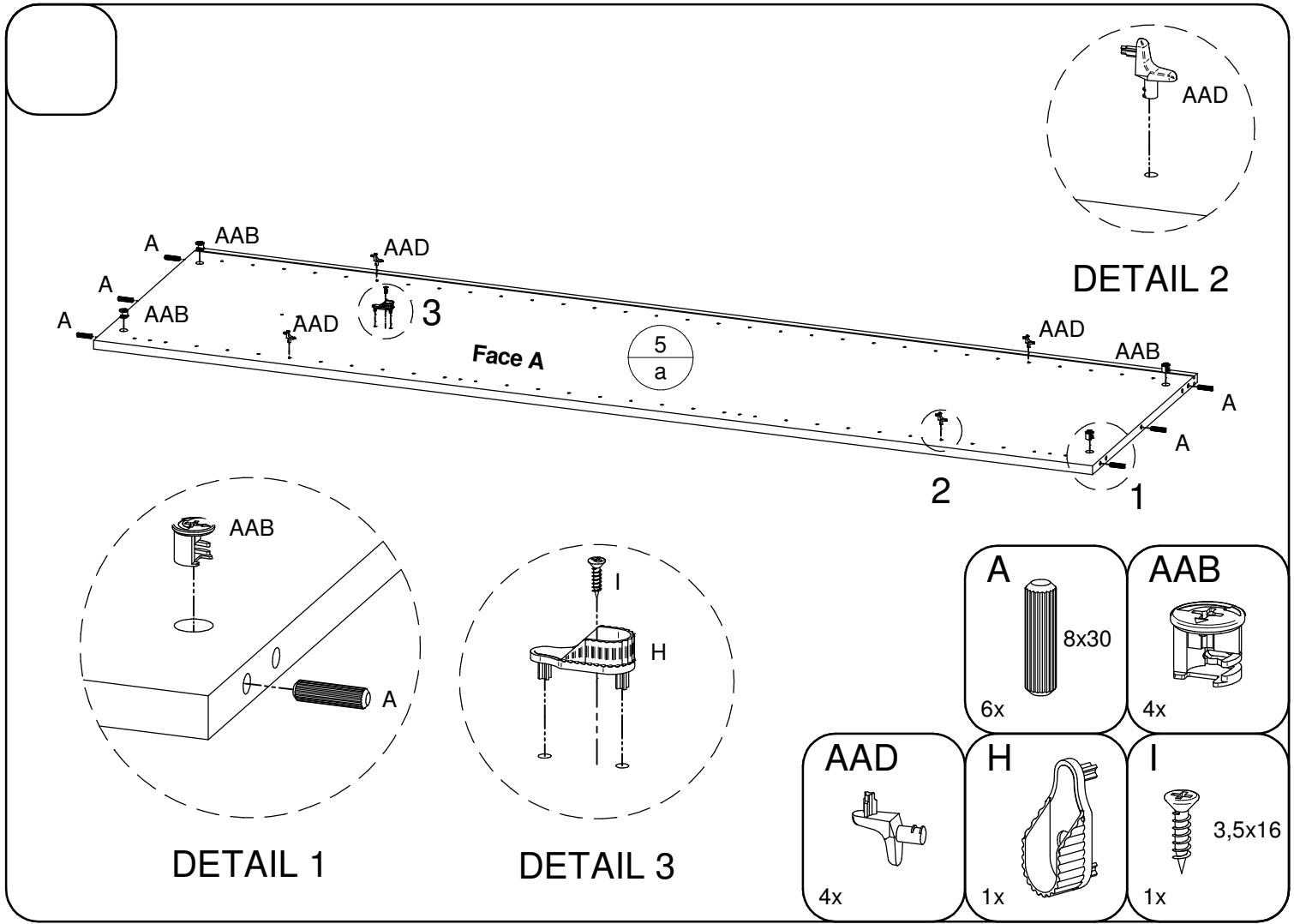

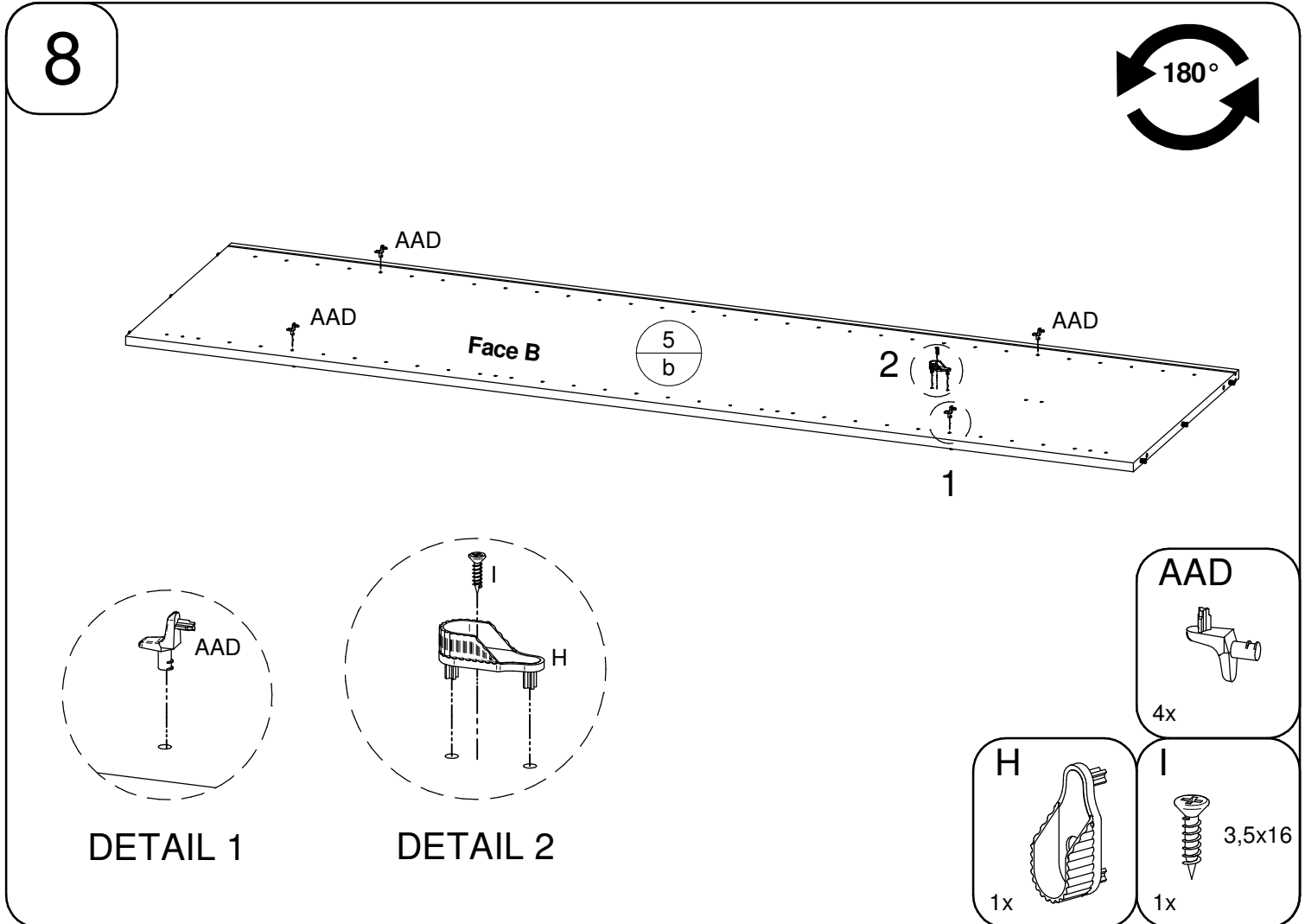
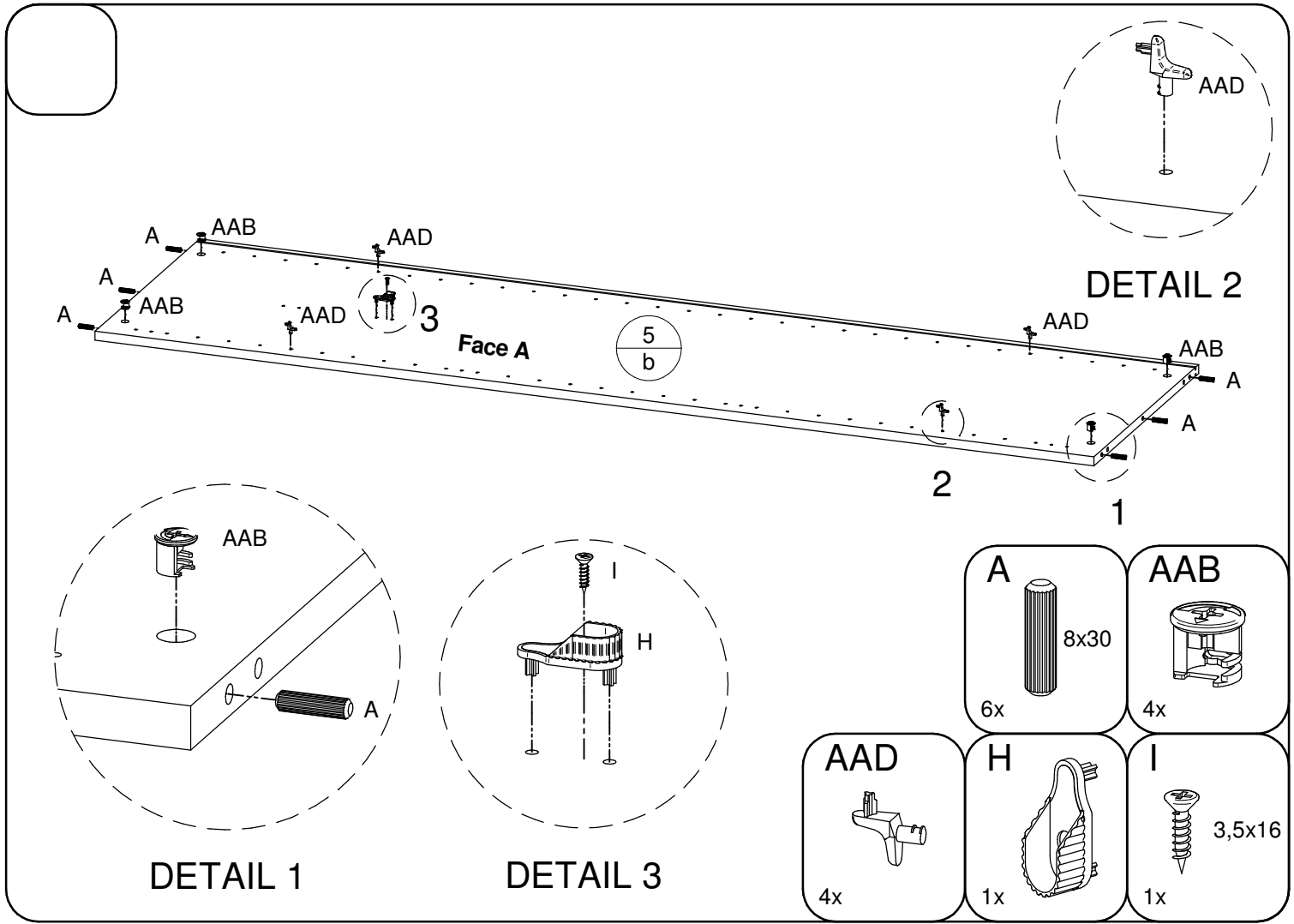

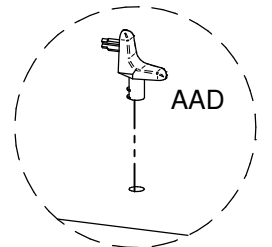

DETAIL 2

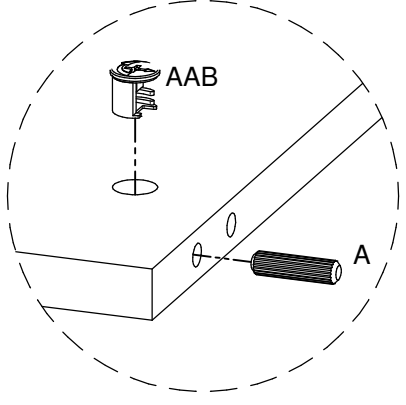
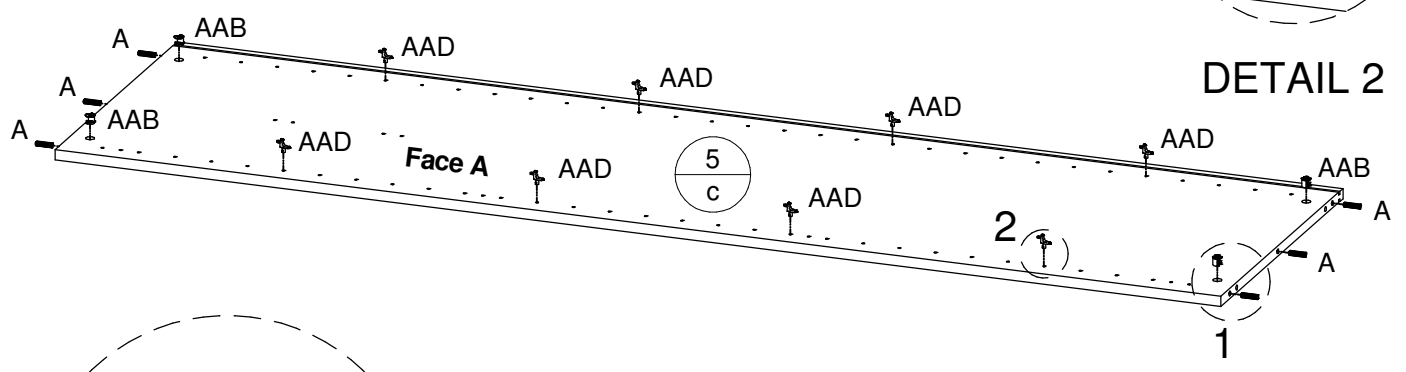

DETAIL 1

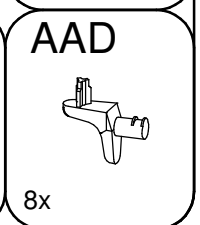
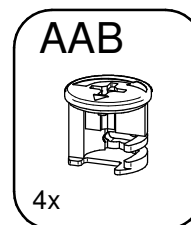
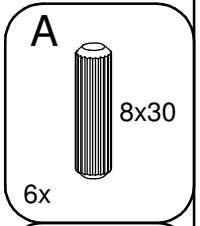

10

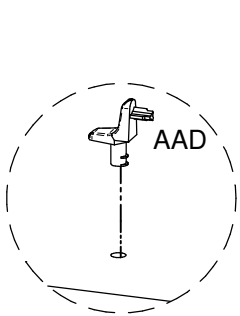
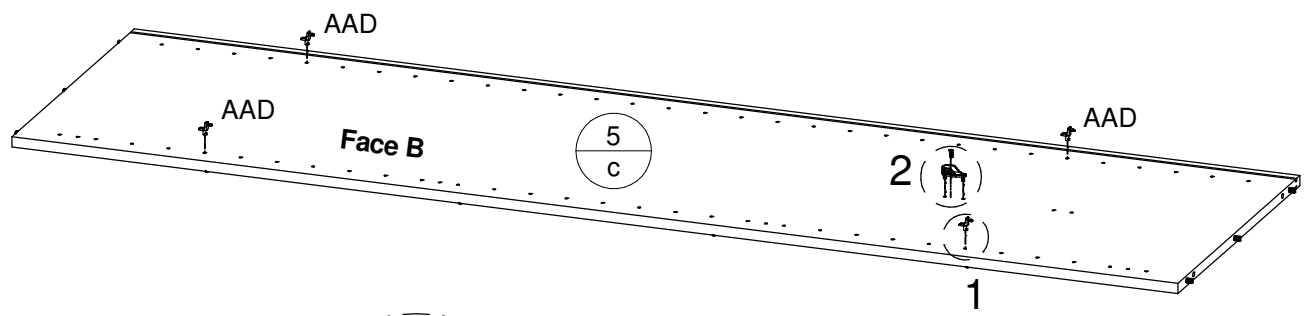
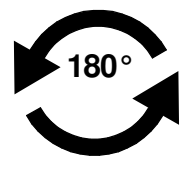

DETAIL 1

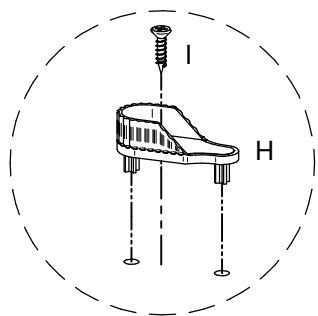

DETAIL 2

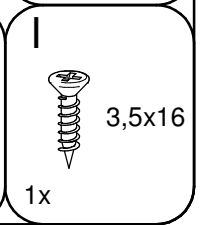
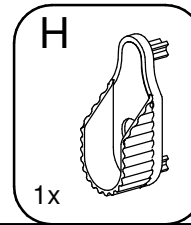
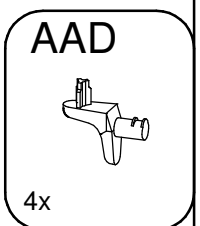



11

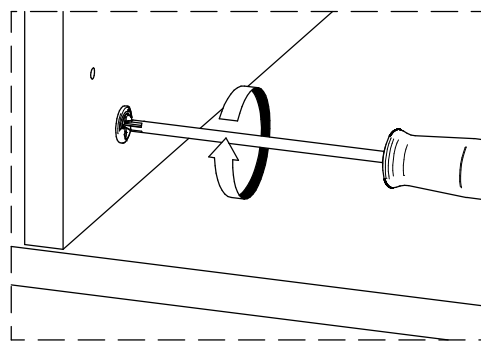
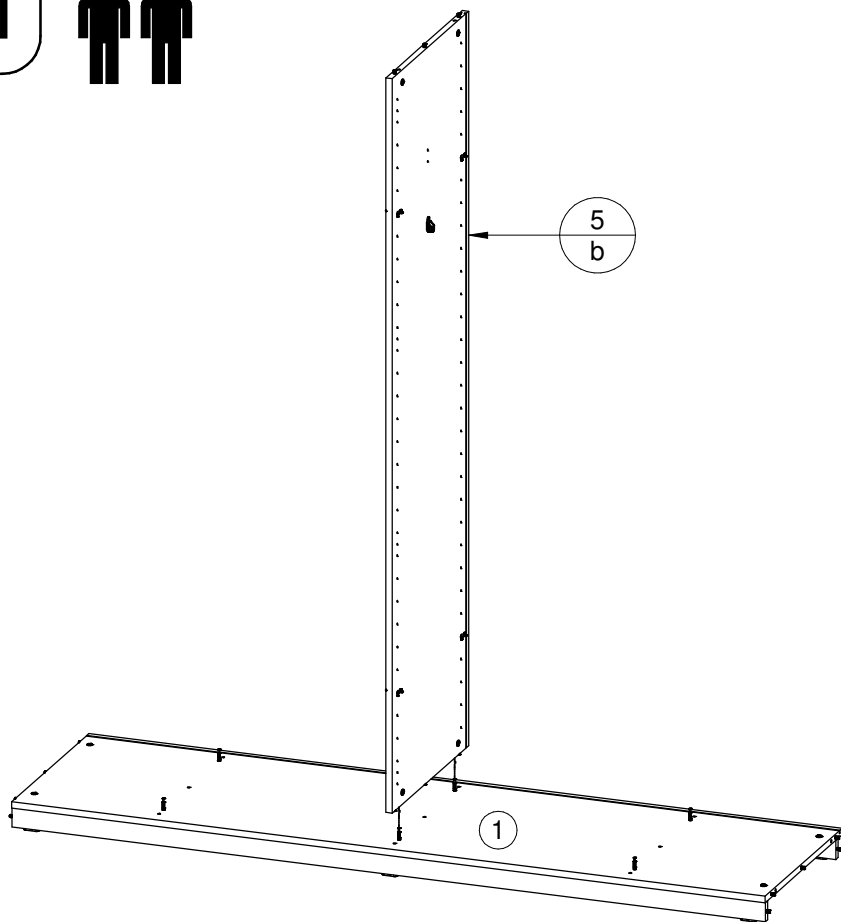

12

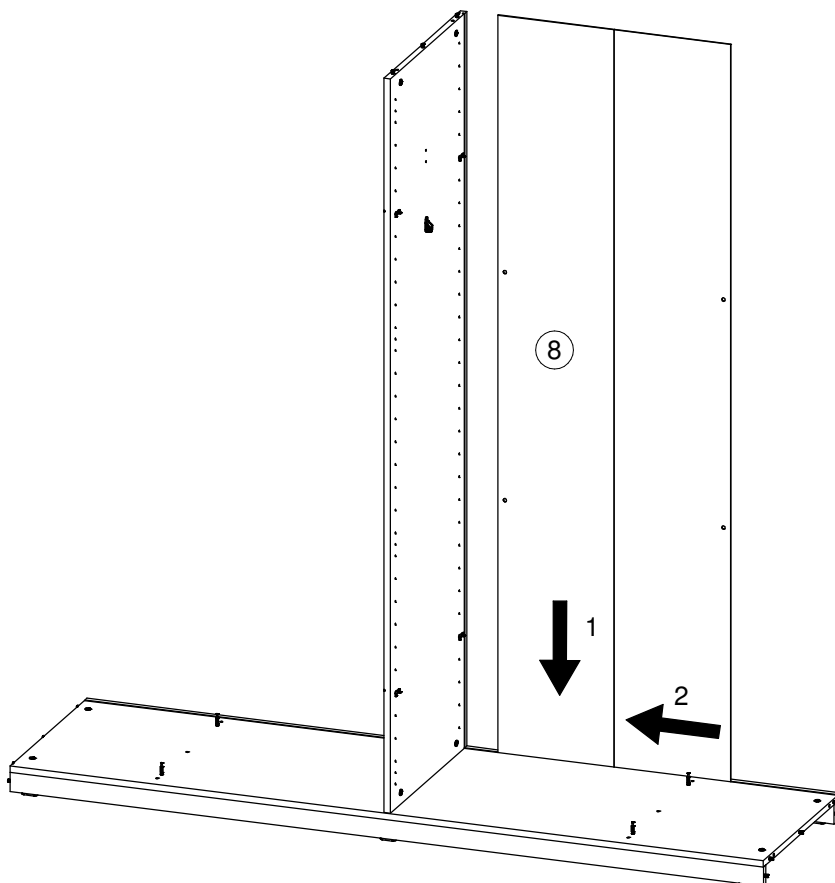

13

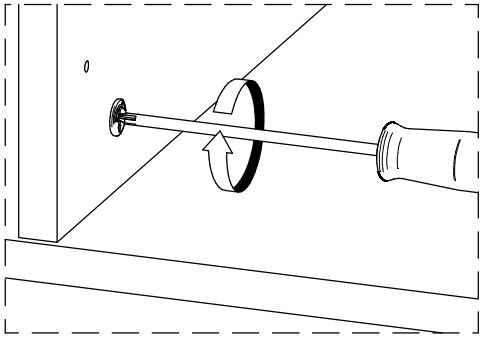
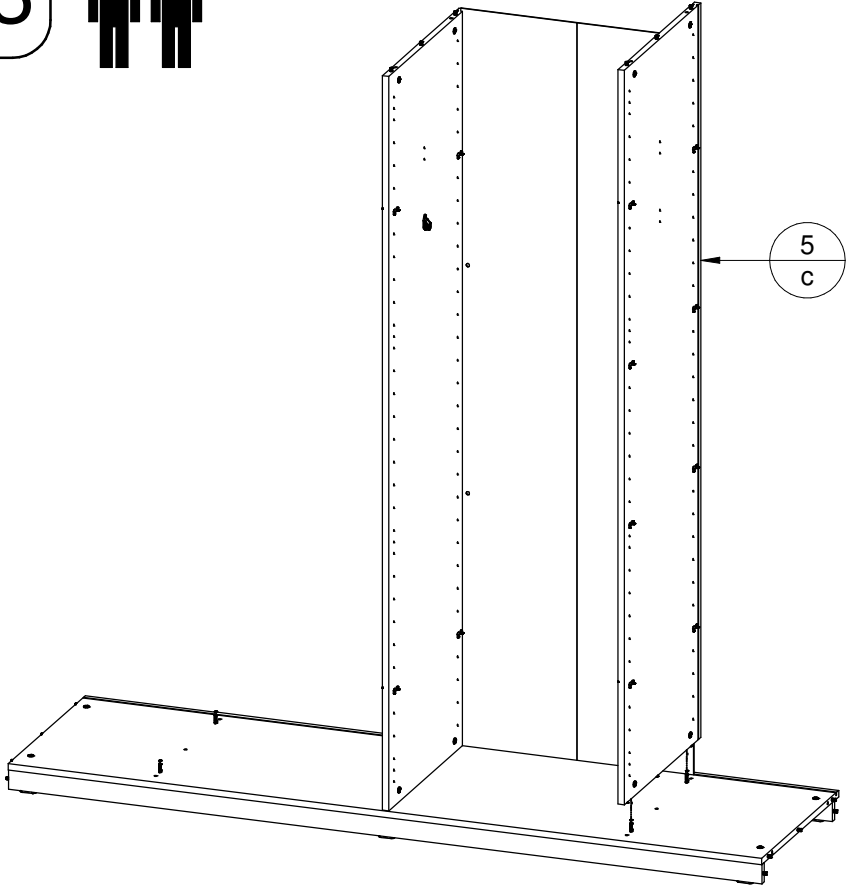

14

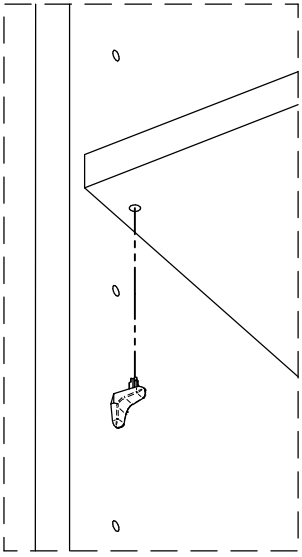
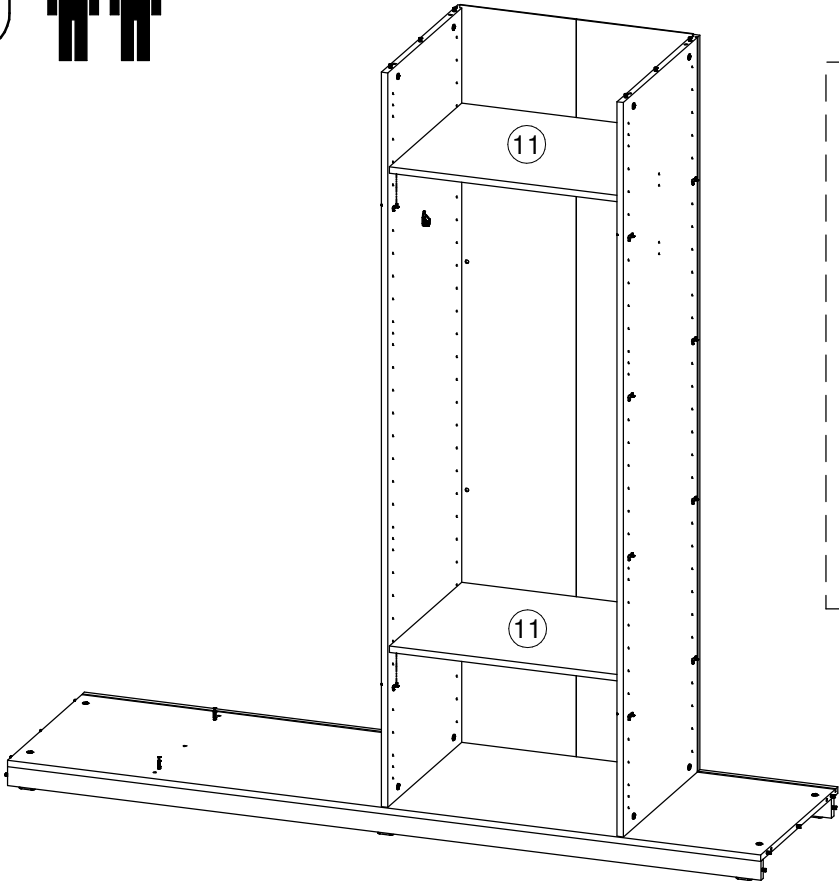
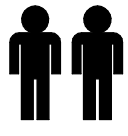

15

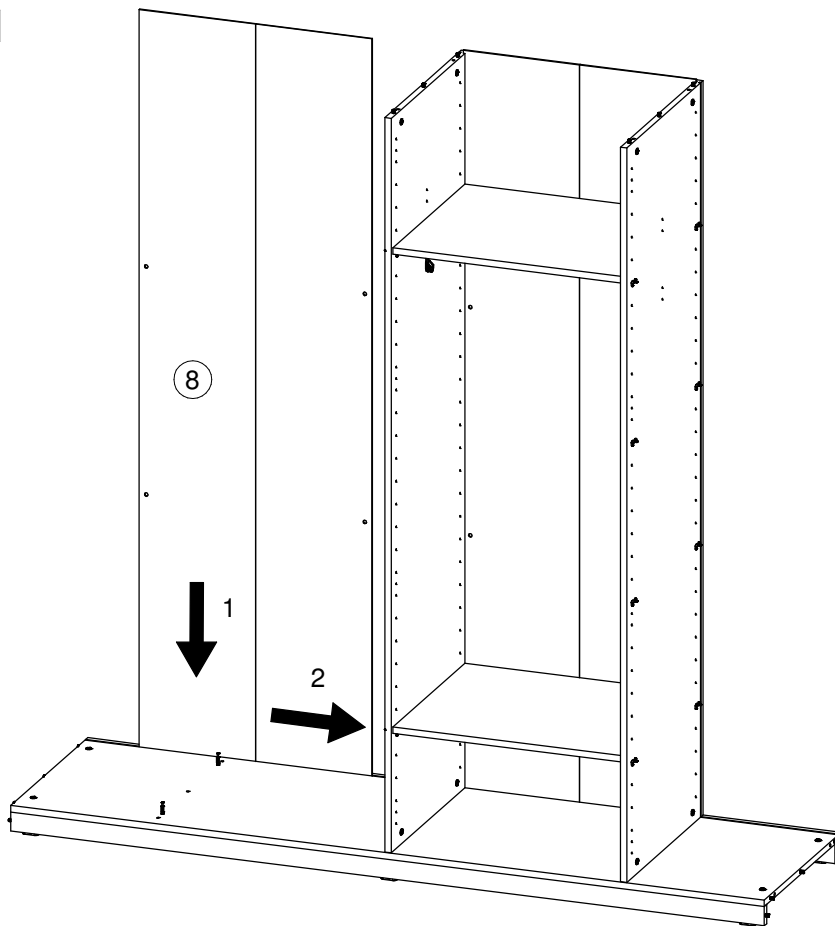

16

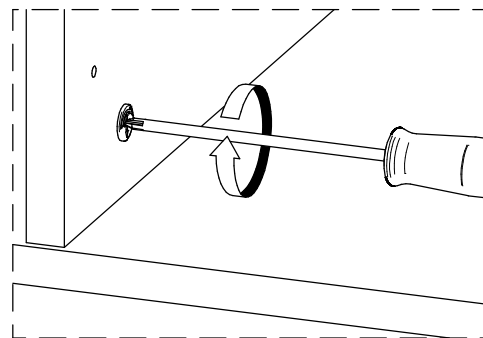
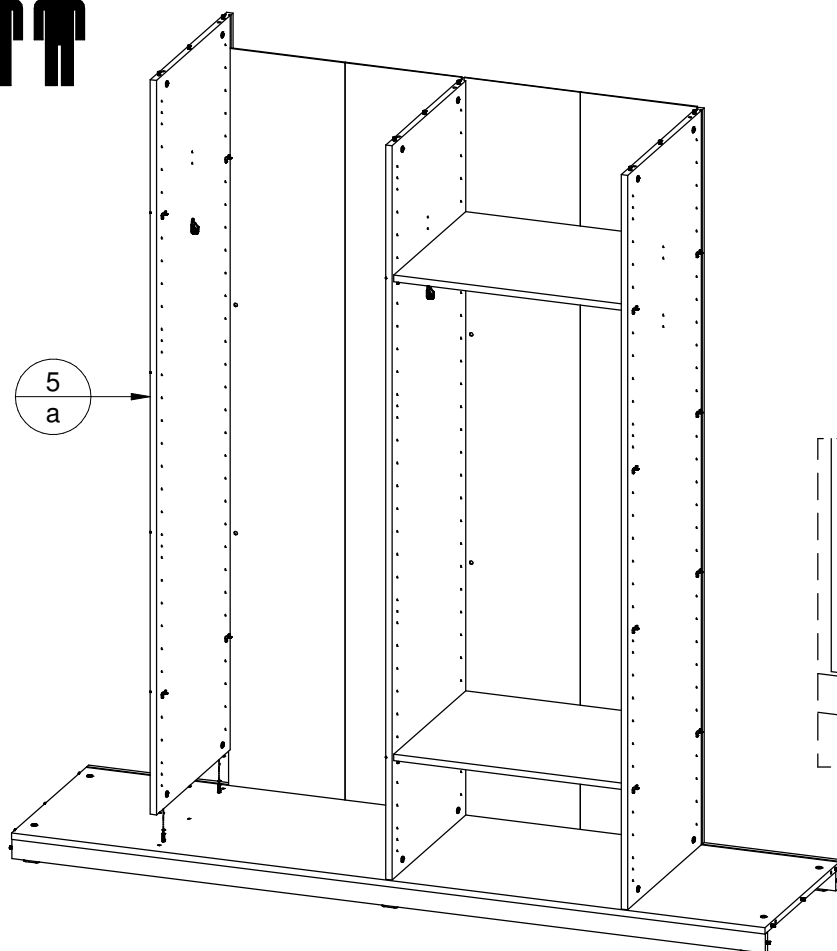

17

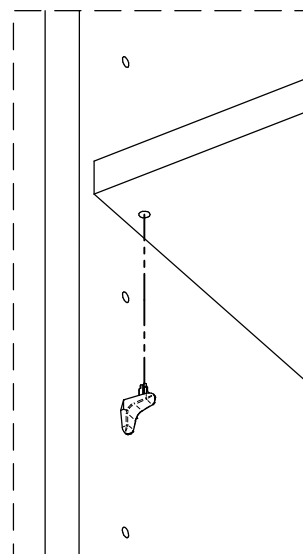
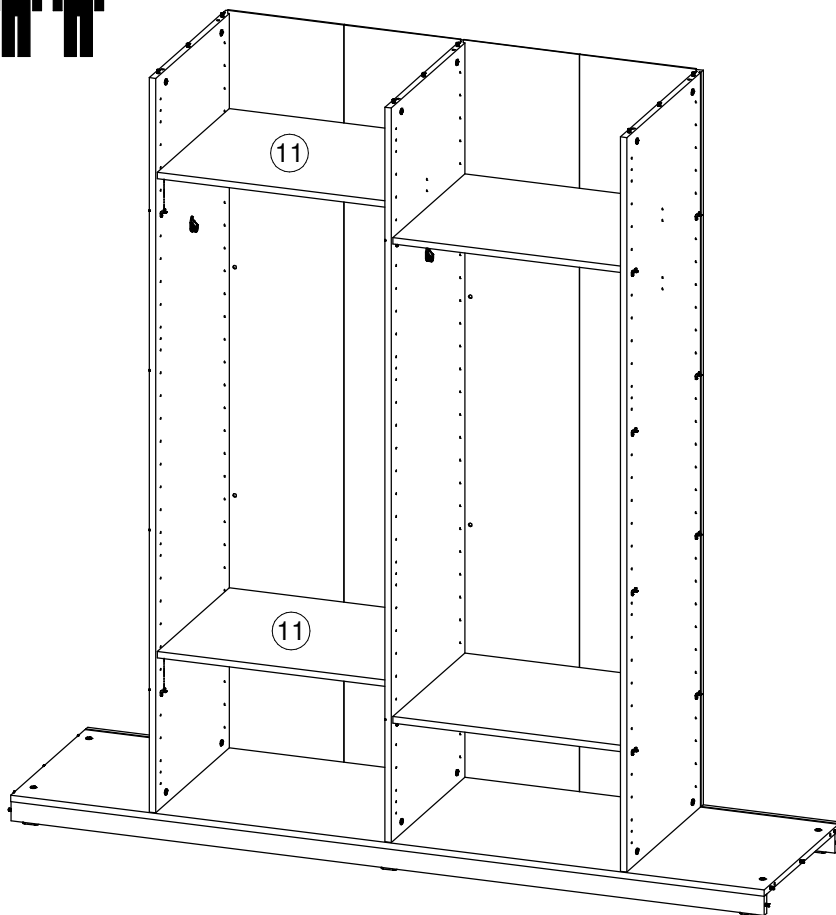

18

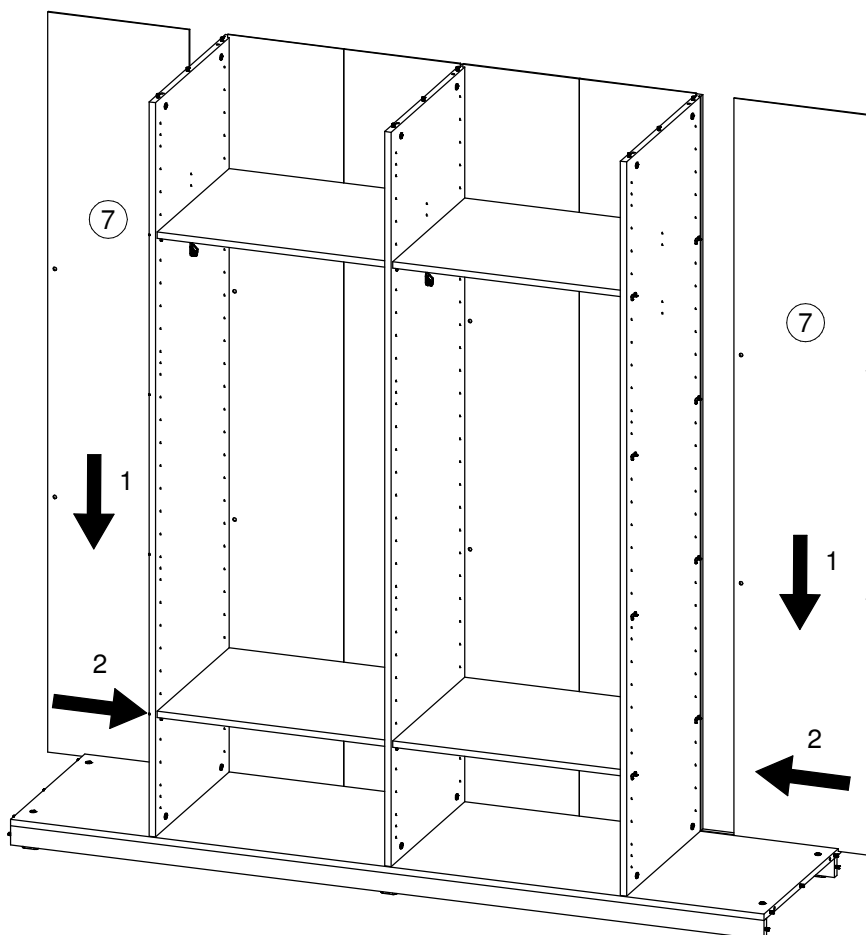

19

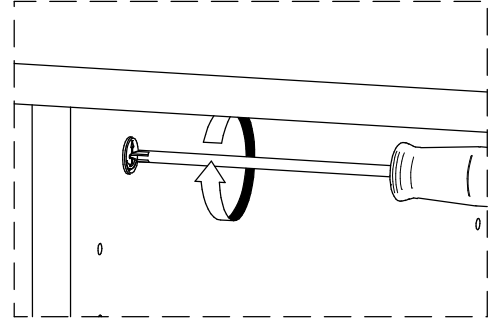
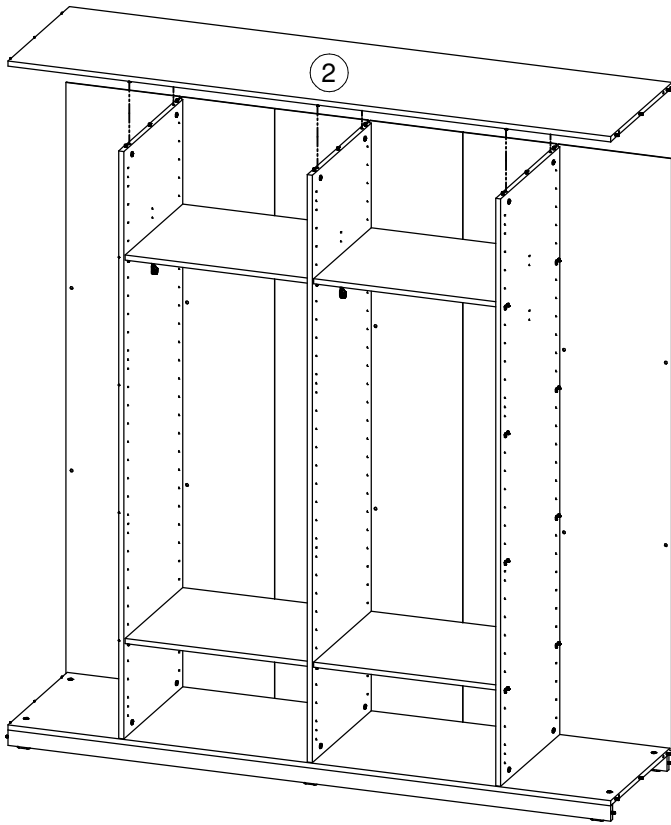
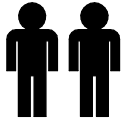

20

De resterende onderdelen uit de beslagzak worden gebruikt in handleiding 2 van het aangekochte meubel.

Les autres pièces de sachet de quincaillerie sont utilisées dans le manuel 2 du meuble acheté.

The remaining parts of the packet with fittings are used in manual 2 of the purchased furniture.

AAC

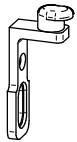

16x

AAD



16x

B

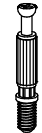

8x

BAG

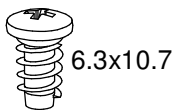

6.3x10.7

16x

I



3.5x16

38x



Deel 2

Partie 2

Part 2

2D Schuifdeur  
2P Portes coulissantes  
2D Sliding doors



Opbouw met 2 personen  
Montage par 2 personnes  
Assembling by 2 persons

Gebruik deze handleiding van begin tot einde voor het probleemloos monteren van uw aangekocht meubel aub.

Veuillez bien suivre nos instructions ci-après lors du montage de votre meuble. Merci.

Please use the manual from the beginning until the end to assemble your newly bought furniture without troubles.

## Handleiding 2

### Manuel 2

### Manual 2

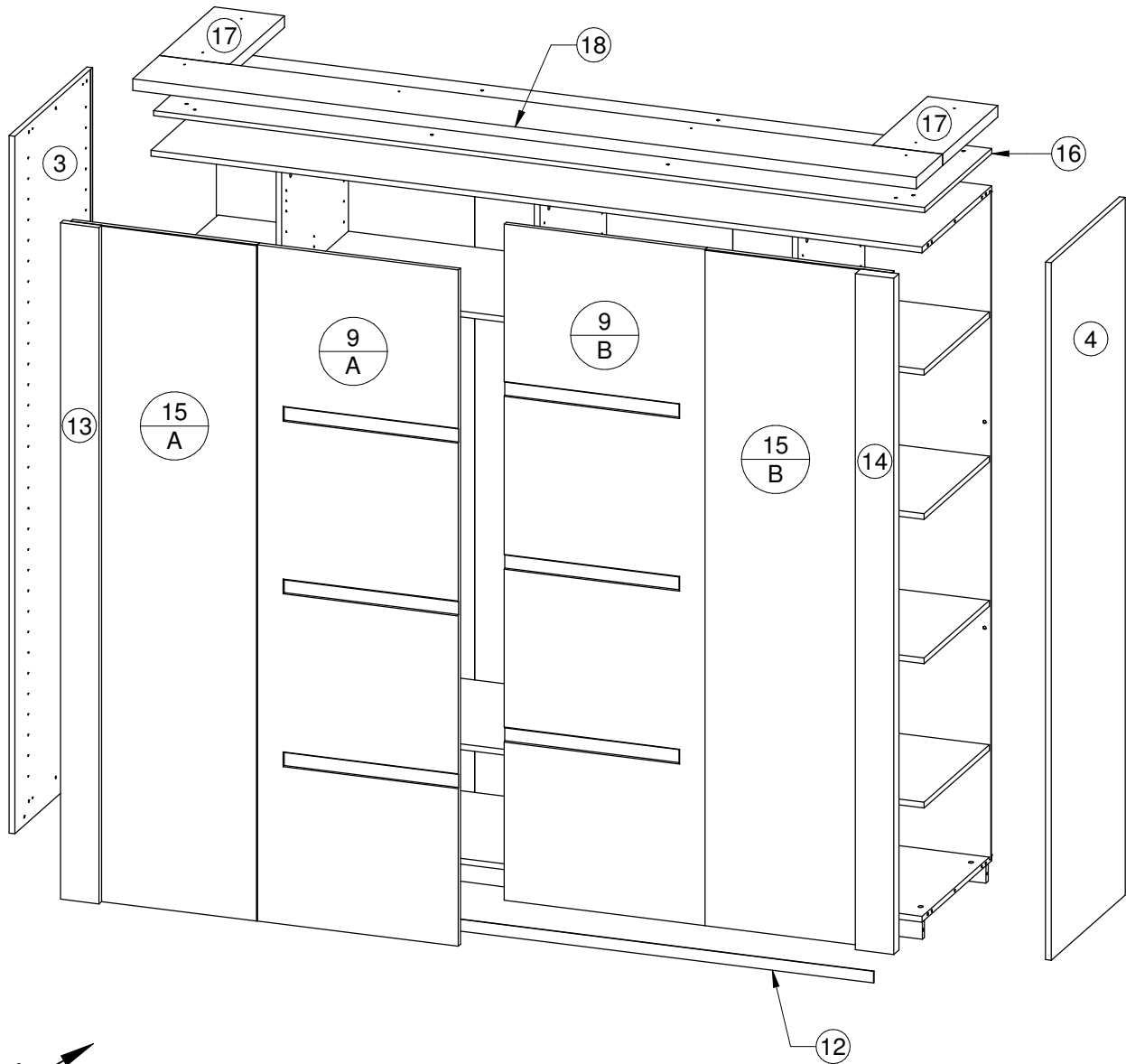
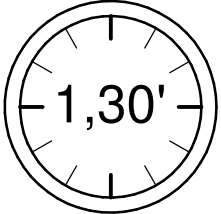
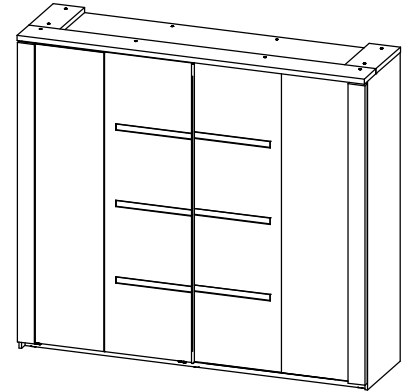

2207mm  
677mm  
2168 / 2453mm

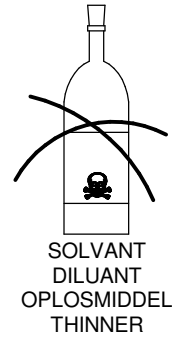
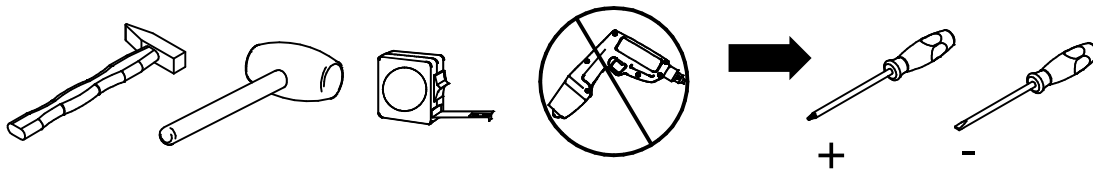

**(FR)** Entretien: utilisez un chiffon légèrement humide et séchez aussitôt. Toute trace de liquide doit être enlevé immédiatement. Meuble inadapté aux pièces humides. N' utilisez jamais du solvant, détergent, diluant, produits chimiques ou cirage. Notice du montage à conserver. Pour tous service apres-vente, rendezvous au magasin avec cette notice.

**(GB)** Maintenance: clean with slightly wet moistened cloth, wipe dry immediately. Wipe off wetness at once. Not suited for humid locations. Never use solvent, cleaner, thinner, chemical products or wax. Retain manual instruction. For the after sales, go back to the shop with this assembly instruction.

**(NL)** Onderhoud: met licht vochtige doek reinigen hierna direct droog wrijven. Vocht op het bovenblad direct opnemen. De meubels zijn niet voor vochtige ruimten bestemd. Gebruik nooit oplosmiddel, reinigingsmiddel, verdunner, chemische producten of boenwas. Montage tekening opbergen. Voor service na verkoop, ga naar uw leverancier met deze montage handleiding.

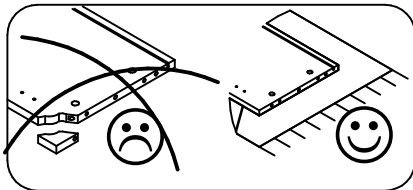

Made in Belgium

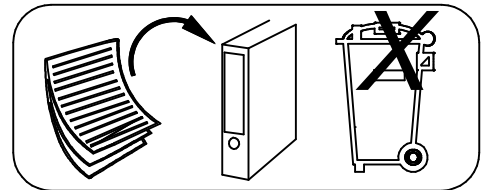

<b>A</b> 8x30 14x	<b>AJ</b> 10x	<b>AAB</b> 20x	<b>BZ</b> 8x	<b>BBD</b> 3,5x12 5x	<b>BBF</b> 4,5x60 8x
<b>BBG</b> 22mm D3 2x	<b>FF2</b> L1880x30x20mm 2x	<b>I</b> 3,5x16 32x	<b>IA7</b> 2100x36x20x8mm 1x	<b>JB</b> 1x	<b>OC</b> 8x20 4x
<b>PA</b> 4x	<b>QD</b> 3,5x16 5x	<b>XI</b> 3,5x14 16x	<b>XS</b> 4x25 8x	<b>YM</b> 4x30 10x	

**Gelieve eerst handleiding 1 te doorlopen a.u.b.**  
**Le premier, suivre le manuel 1 s.v.p.**  
**Please follow manual 1 first before continuing this one.**

De resterende onderdelen uit handleiding 1 van het aangekochte meubel:

Les autres pièces du manuel 1 du meuble acheté:

The remaining parts from manual 1 of the purchased furniture:

Beslagzak / sachet de quincaillerie / packet with fittings

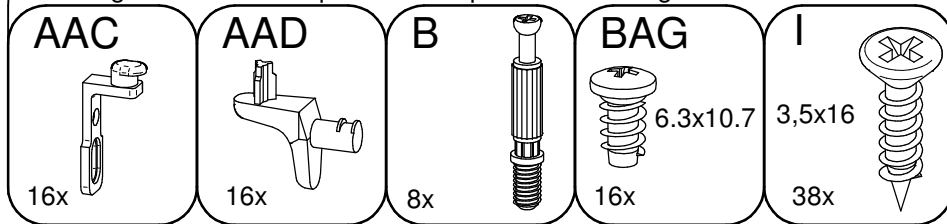

Doos 1 / boîte 1 / box 1

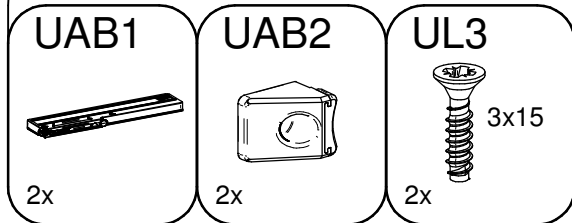

Afhankelijk van de kastbreedte:

Dépendant de largeur de l'armoire:

Depends on the width of the cabinet:

Doos 2 / boîte 2 / box 2

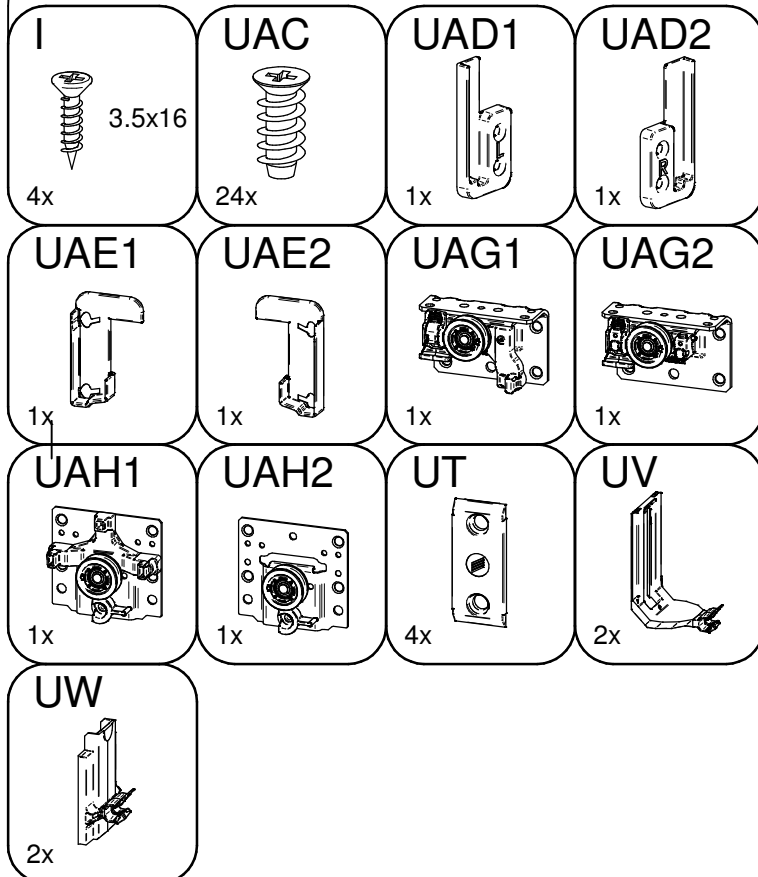

217cm

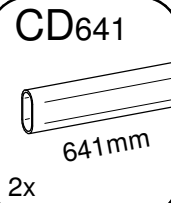

641mm

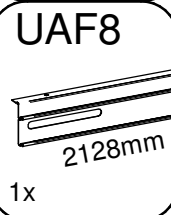

2128mm



2124mm

245cm

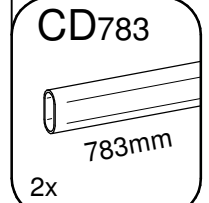

783mm

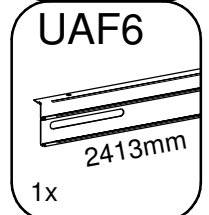

2413mm



2409mm



21

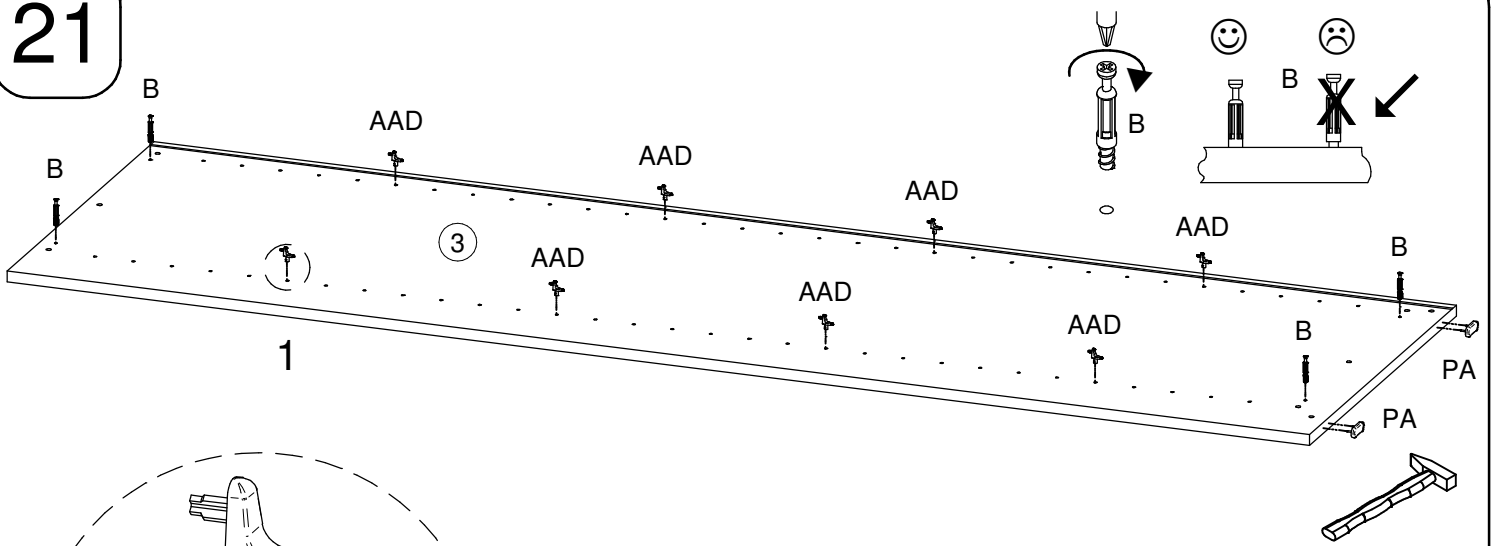

1

AAD

DETAIL 1

50 PA

PA 50

AAD

8x

B

4x

PA

2x

22

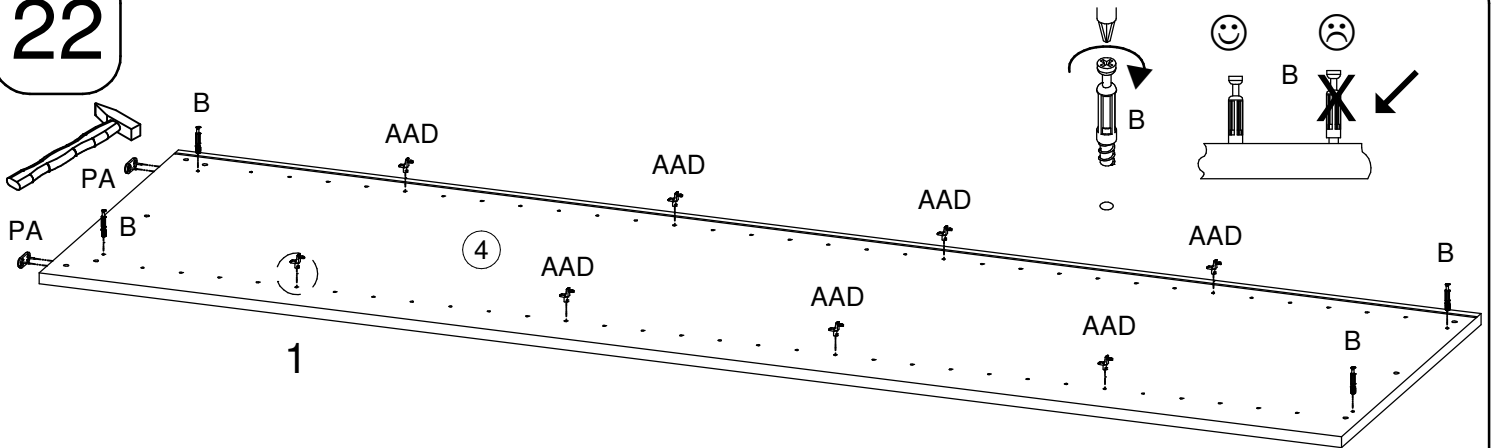

1

AAD

DETAIL 1

50 PA

PA 50

AAD

8x

B

4x

PA

2x

23

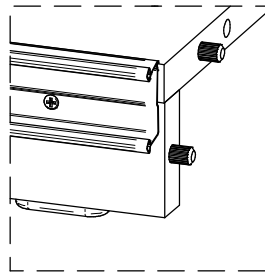
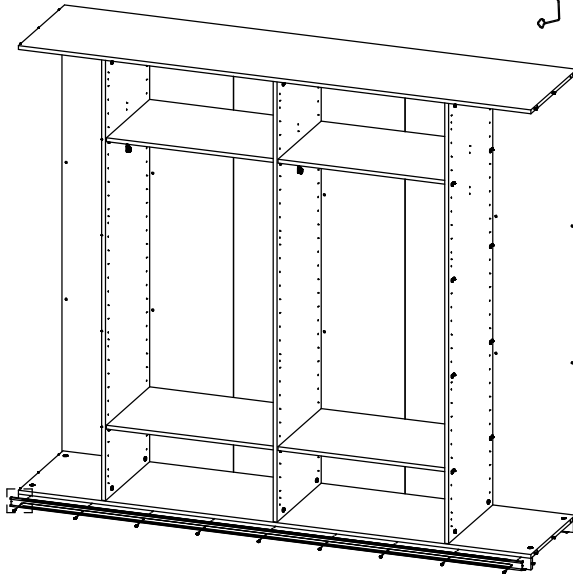

217cm

UZ8



2124mm

1x

|



3.5x16

\*x

Of / ou / or

245cm

UZ6



2409mm

1x

|

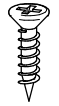

3.5x16

\*x

1

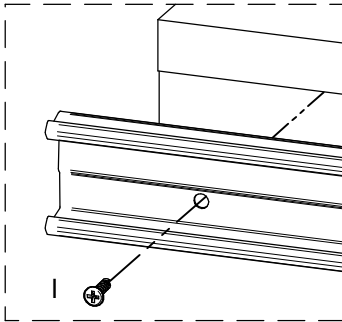

DETAIL 1

\*Het aantal schroeven is afhankelijk van de kastbreedte

\*Le nombre de vis dépend de la largeur de l'armoire

\*The number of screws depends on the width of the cabinet

24

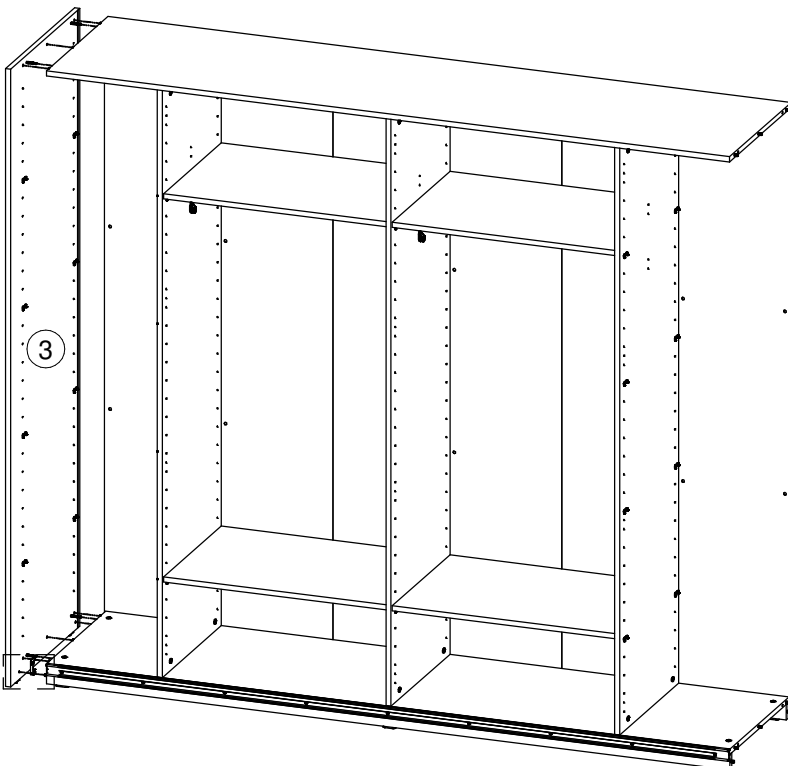

3

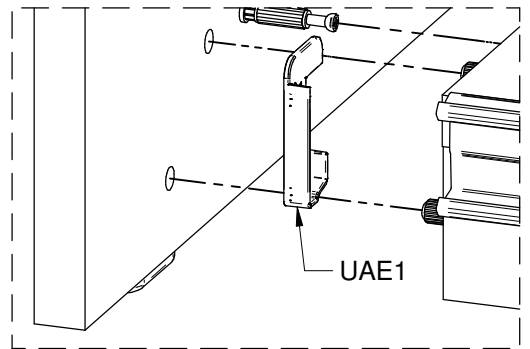

UAE1

DETAIL 1

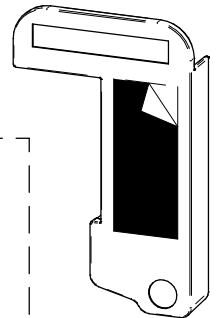
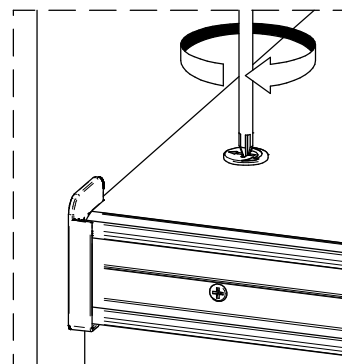

UAE1

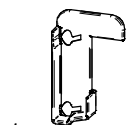

1x

25

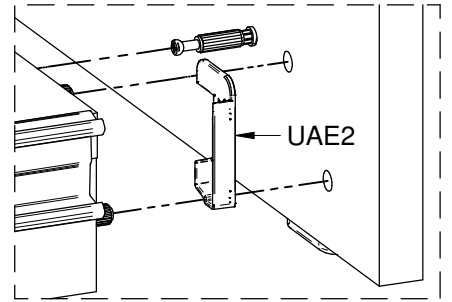
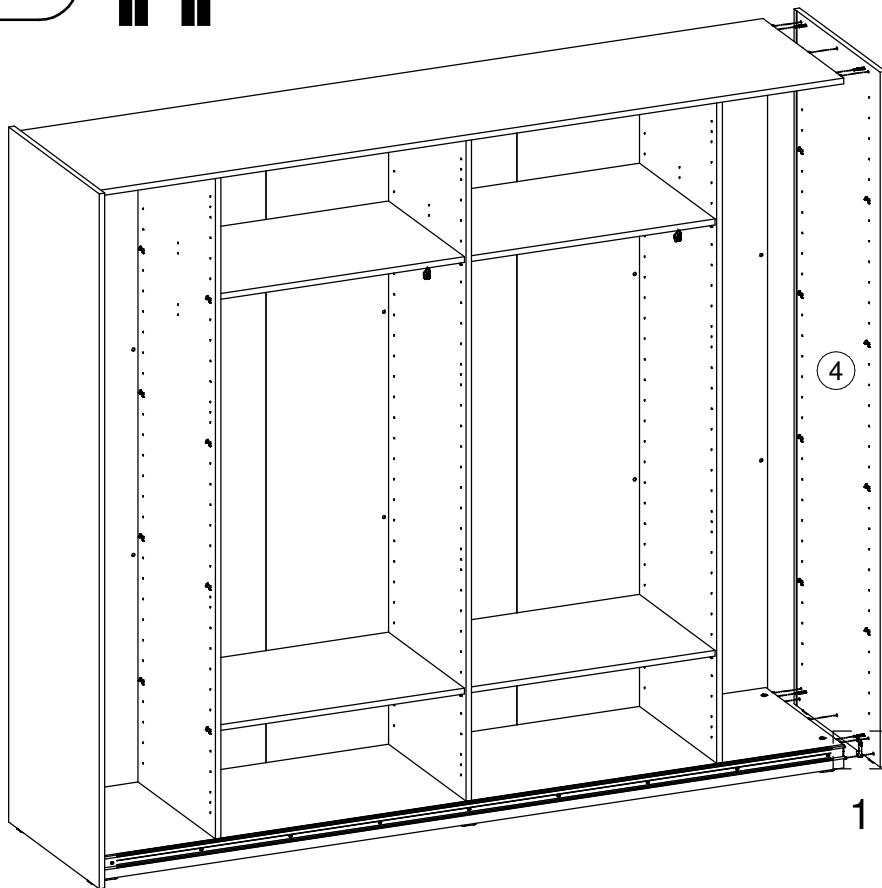

DETAIL 1

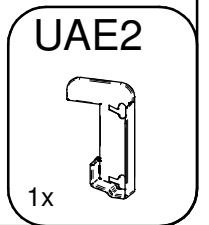
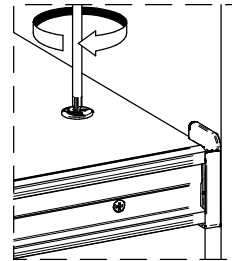
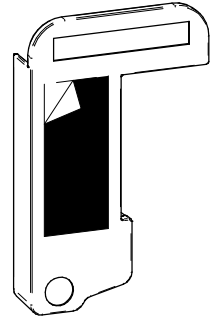

26

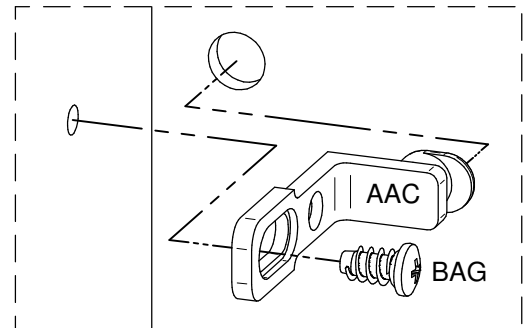
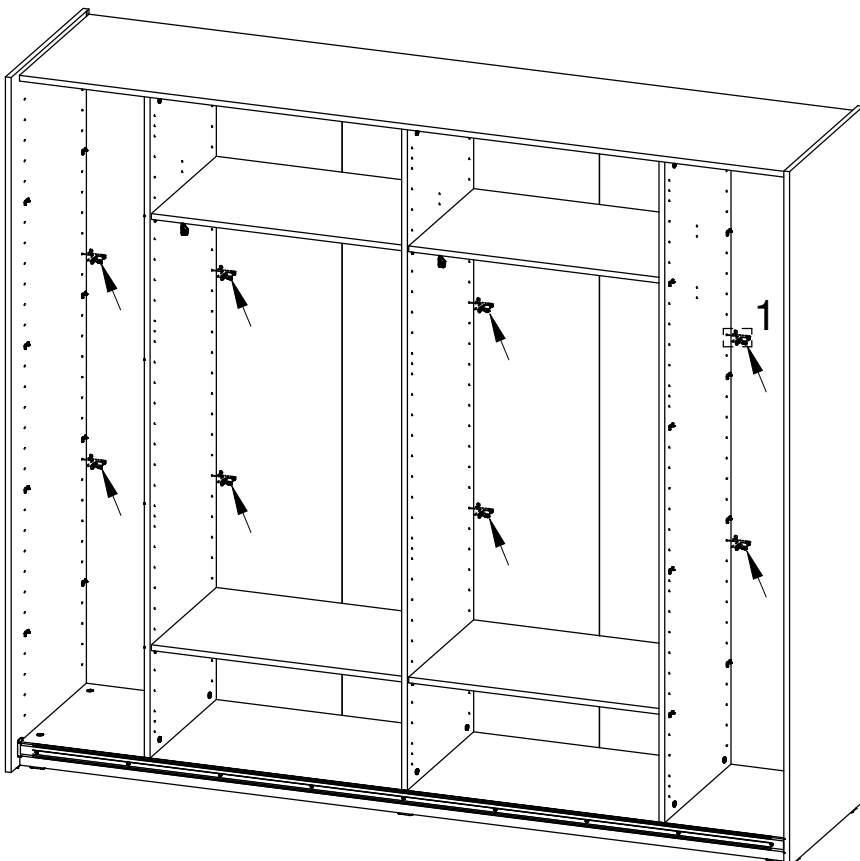

DETAIL 1

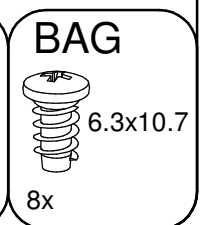
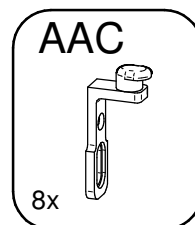

27

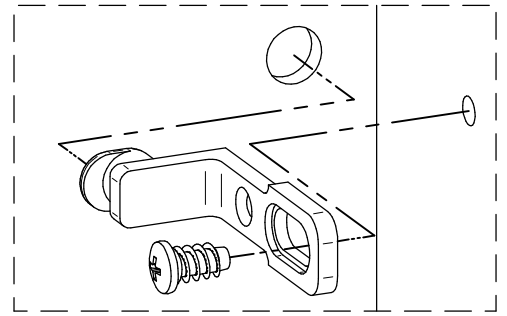
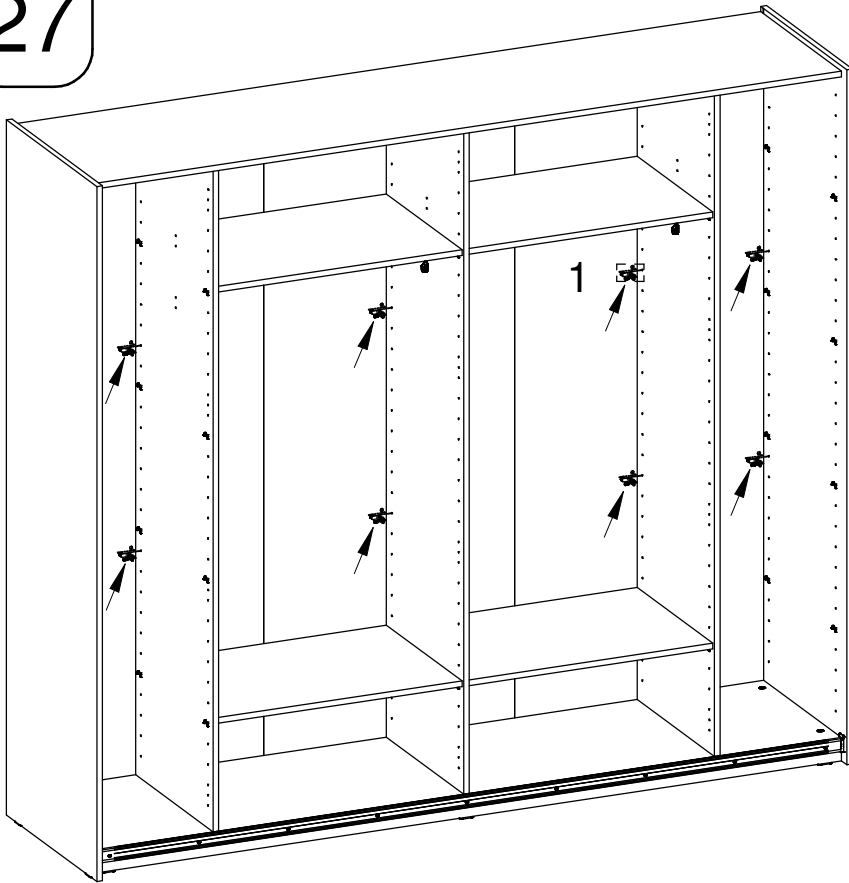

DETAIL 1

AAC

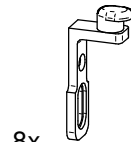

8x

BAG

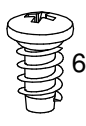

6.3x10.7

8x

28

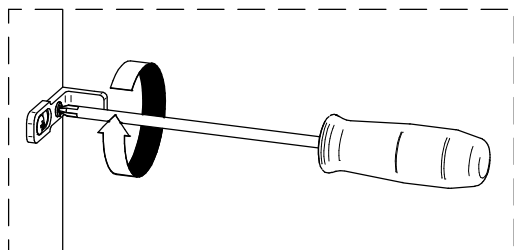
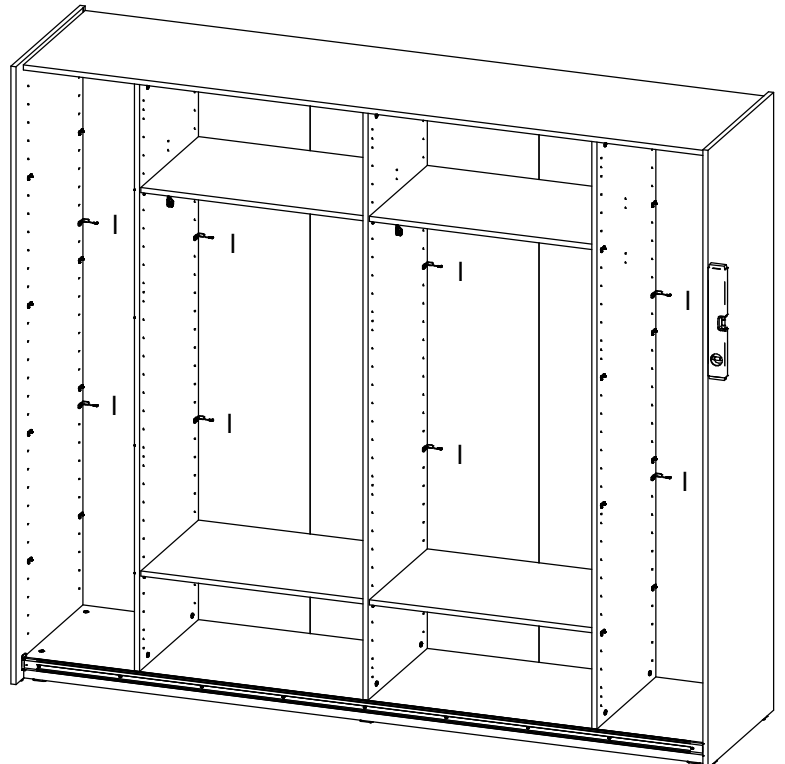

3,5x16

8x

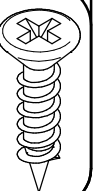

29

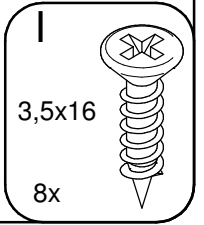
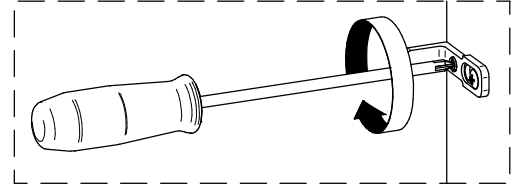
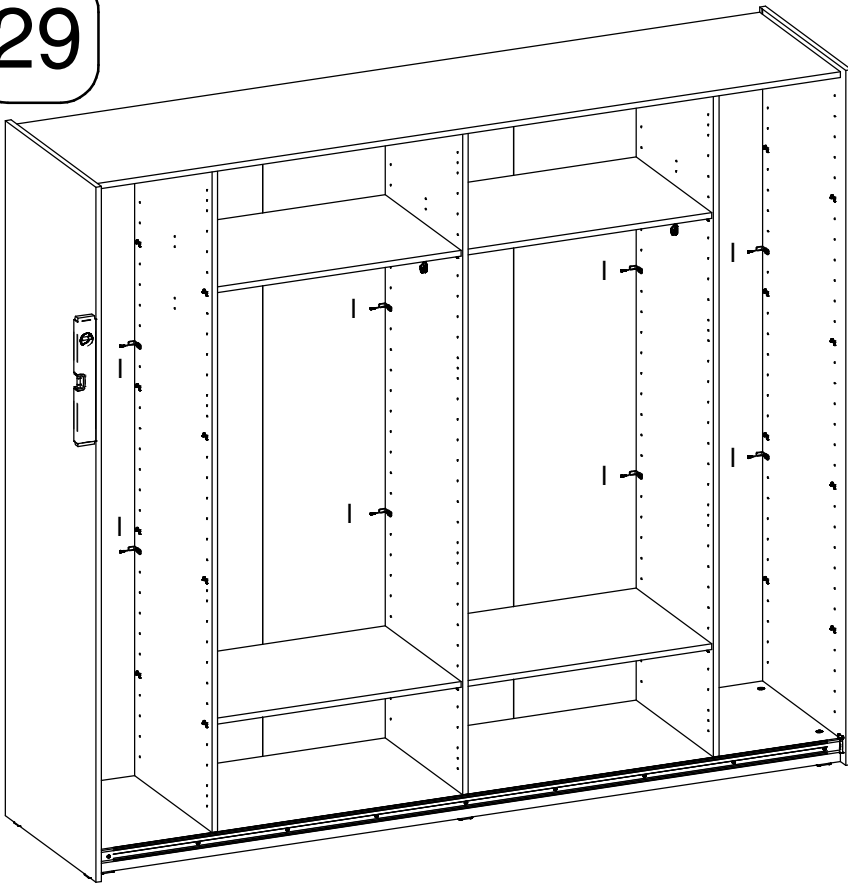

30

1

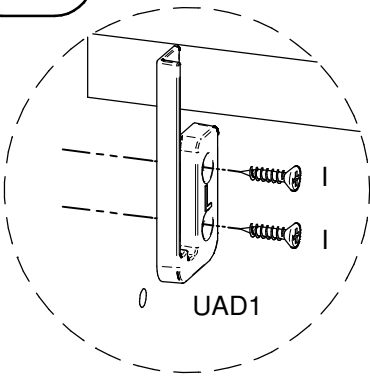
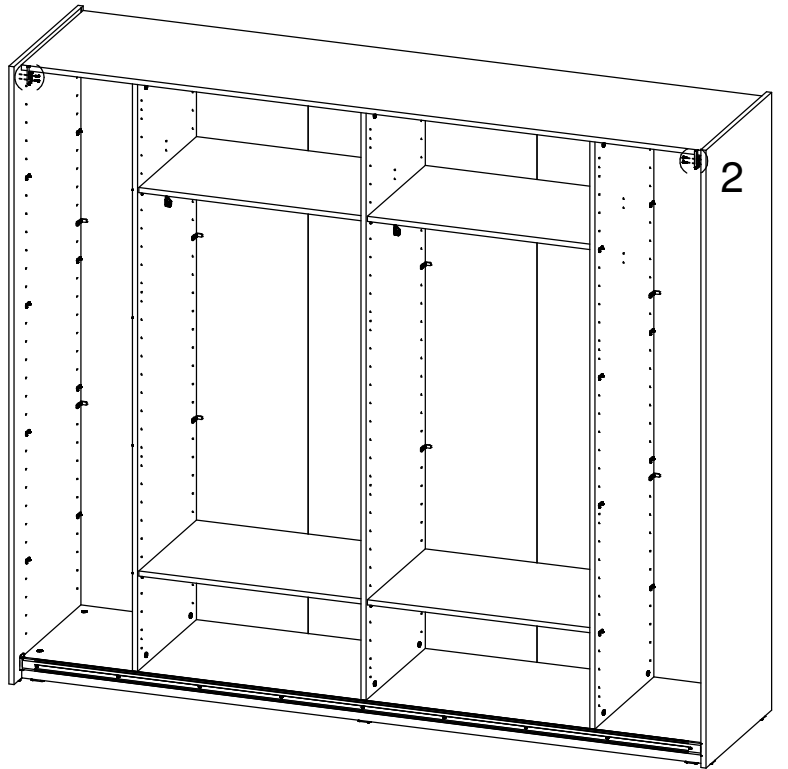

DETAIL 1

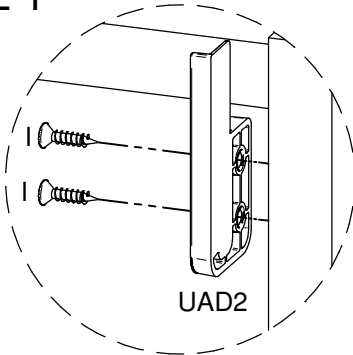
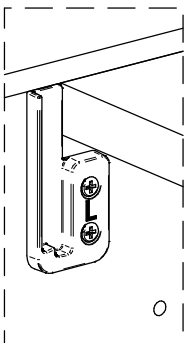

DETAIL 2

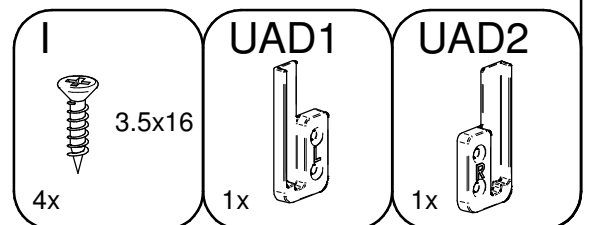

31

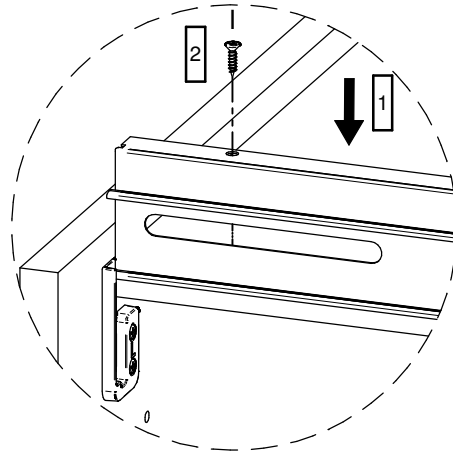
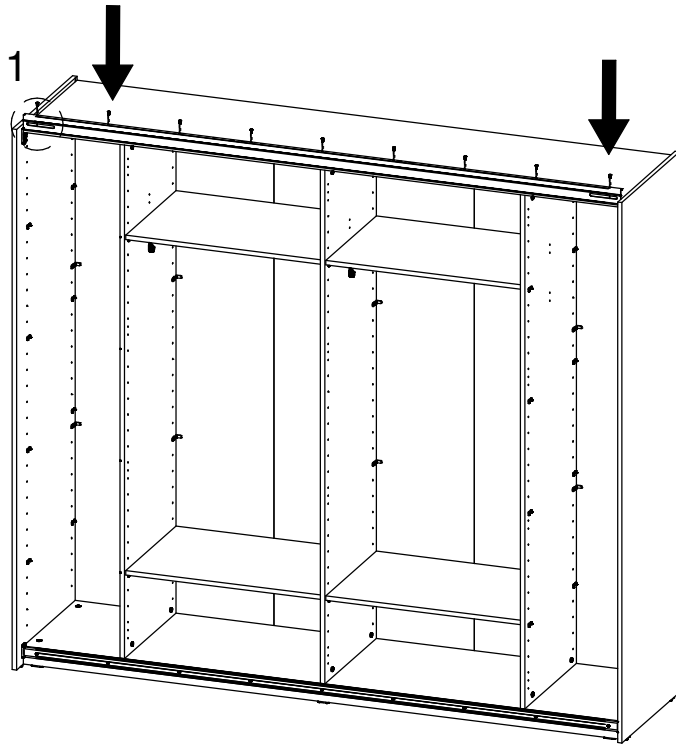
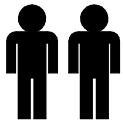

DETAIL 1

\*Het aantal schroeven is afhankelijk van de kastbreedte

\*Le nombre de vis dépend de la largeur de l'armoire

\*The number of screws depends on the width of the cabinet

217cm

UAF8

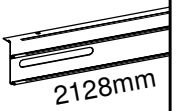

1x

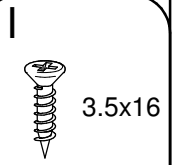

\*x

Of / ou / or

245cm

UAF6

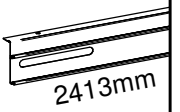

1x

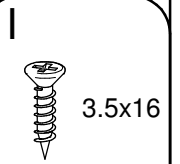

\*x

32

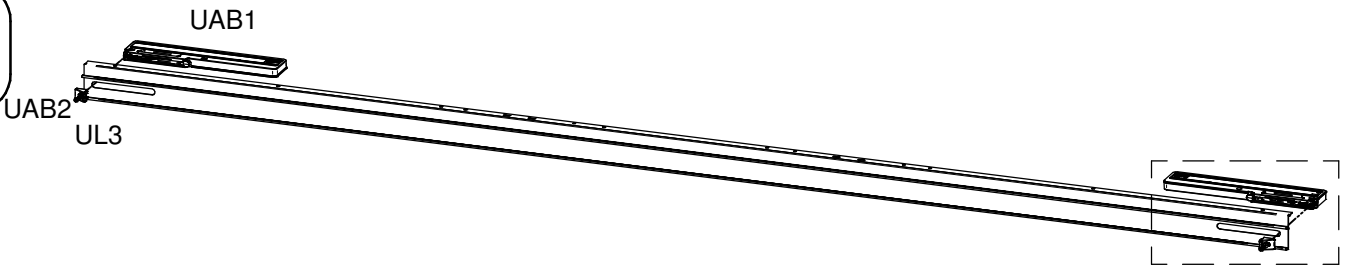

1

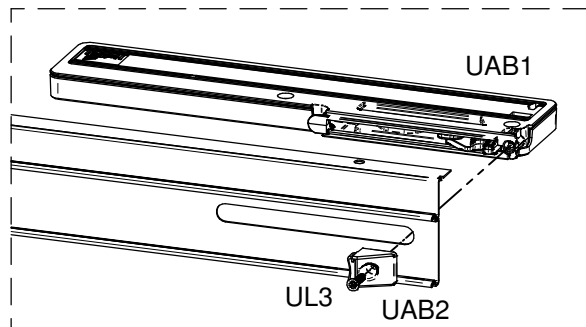
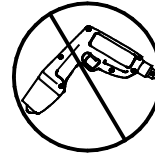
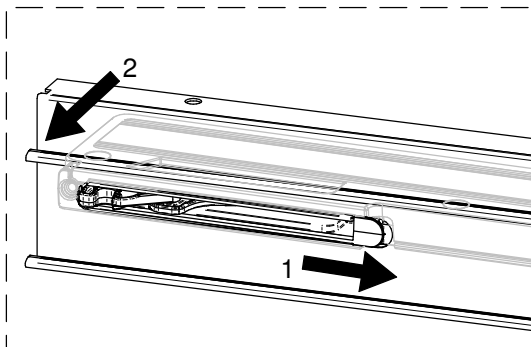

DETAIL 1

UL3



2x

UAB2

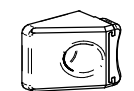

2x

UAB1



2x

33

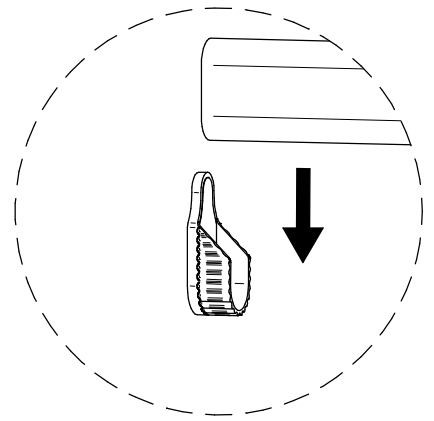
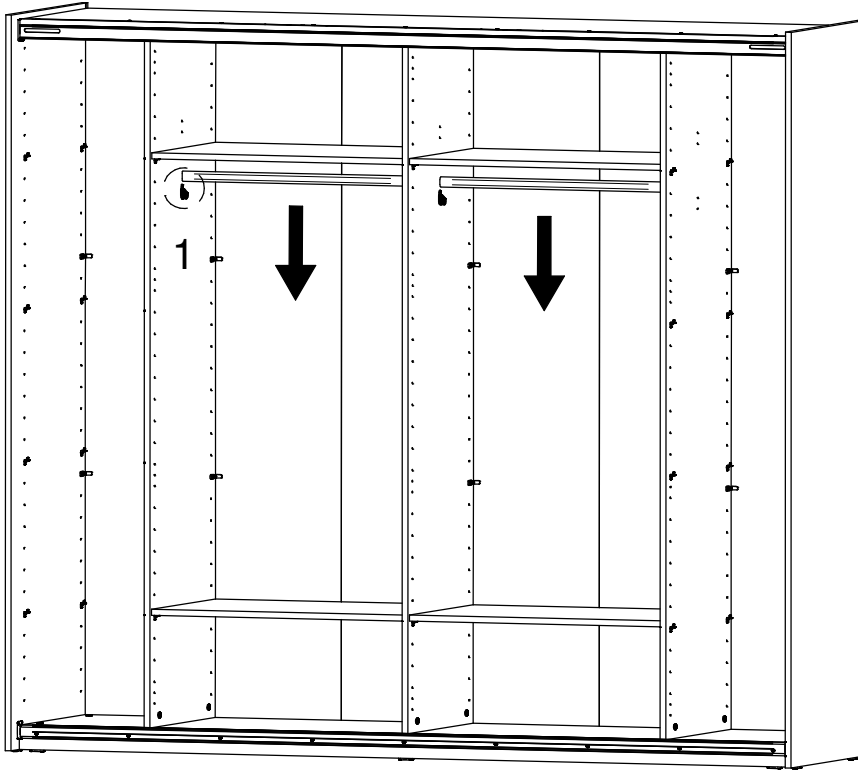

DETAIL 1

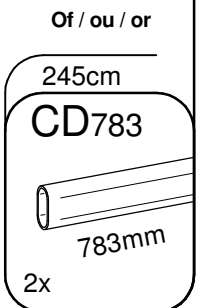
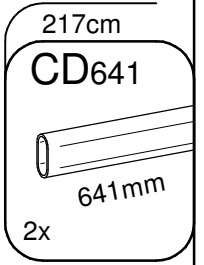

Of / ou / or

34

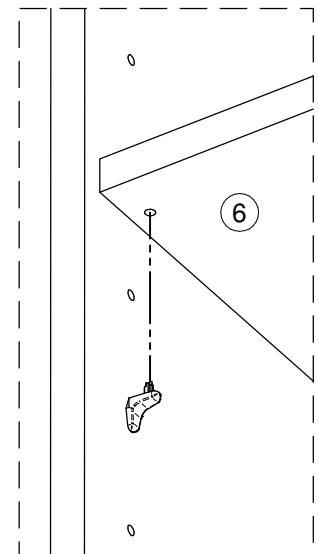
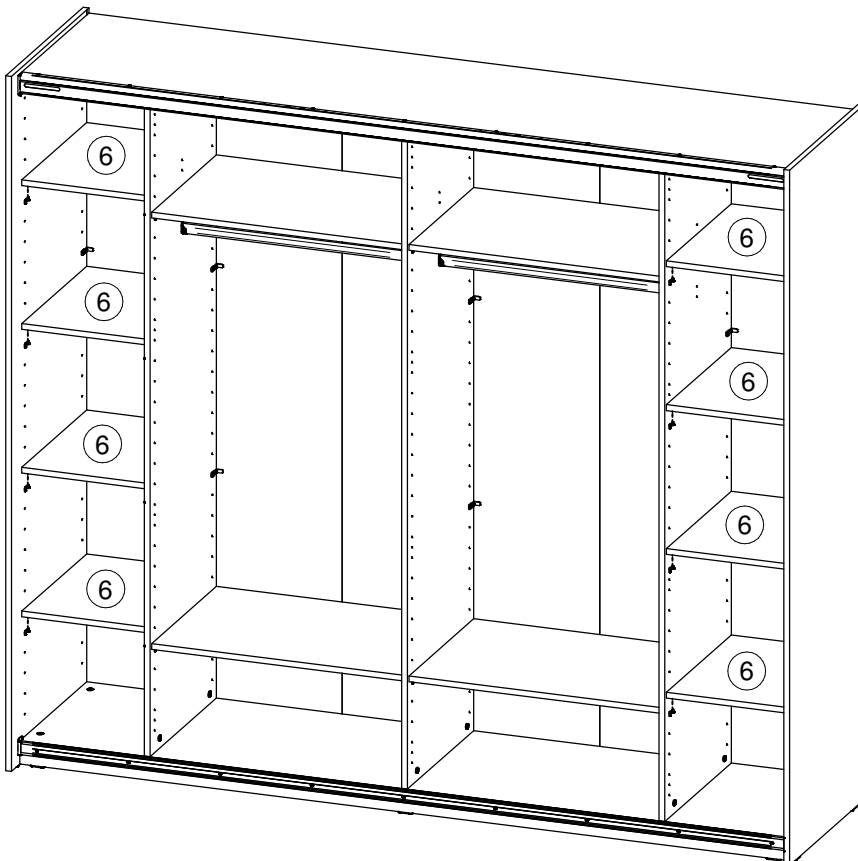

35

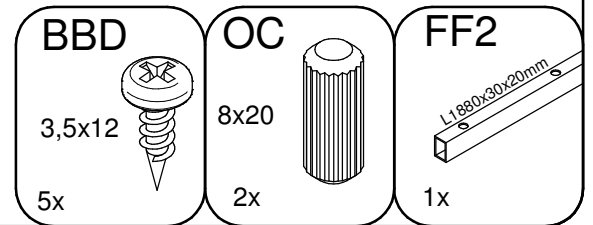
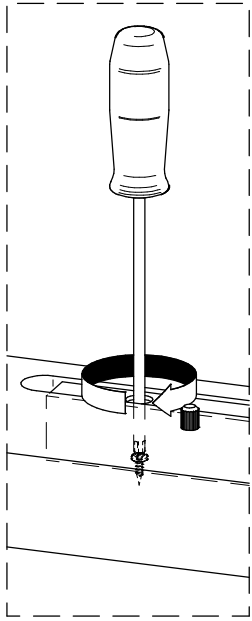
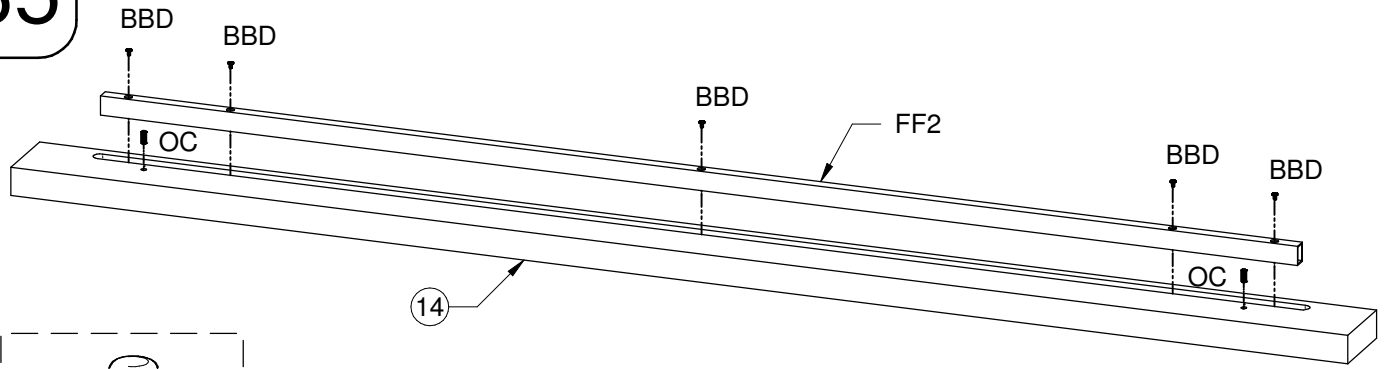

36

2X

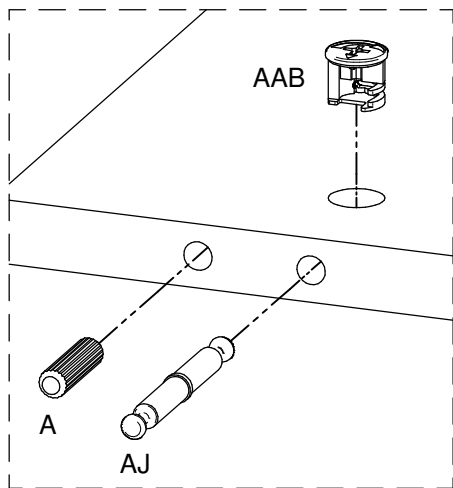
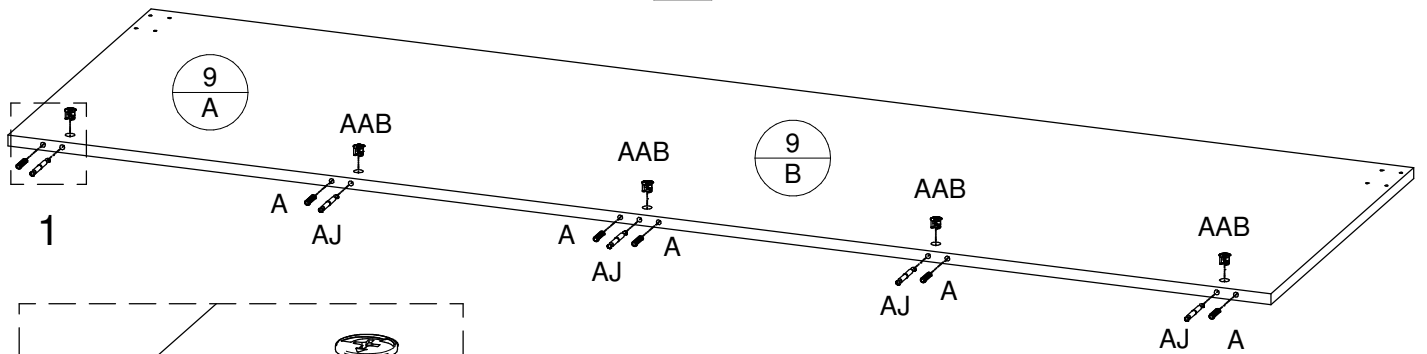

Stift niet volledig aandraaien  
Ne serrez pas complètement la goupille  
Do not fully fasten the pin

DETAIL 1

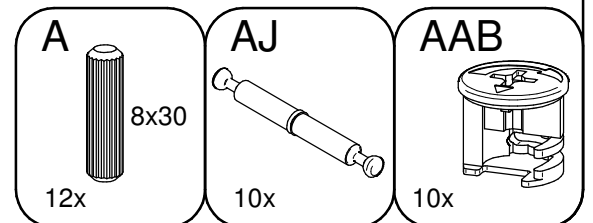



37

2X

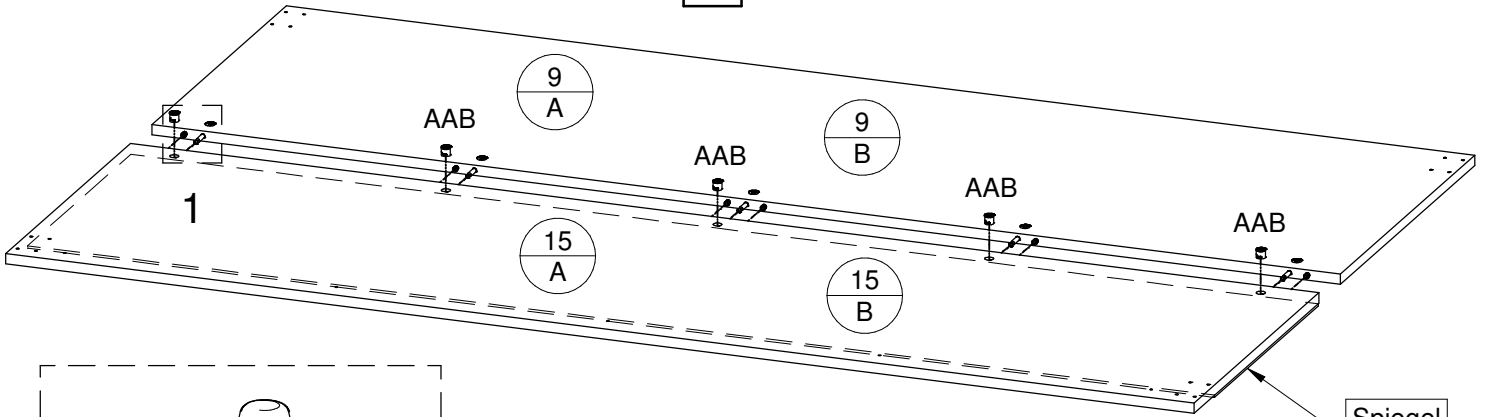

Spiegel  
Mirror

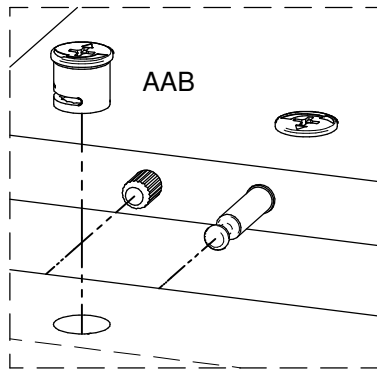
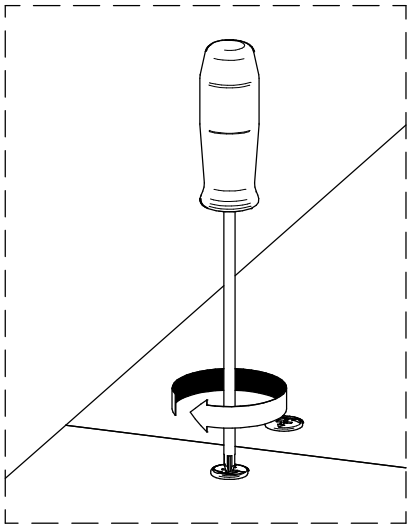

DETAIL 1

Stift volledig aandraaien  
 Serrez complètement la goupille  
 Fully fasten the pin

**AAB**

10x

38

2X

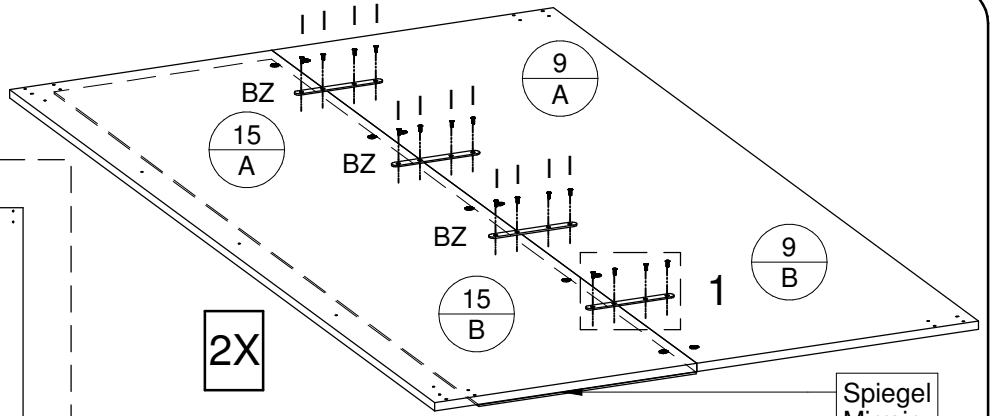

Spiegel  
Mirror

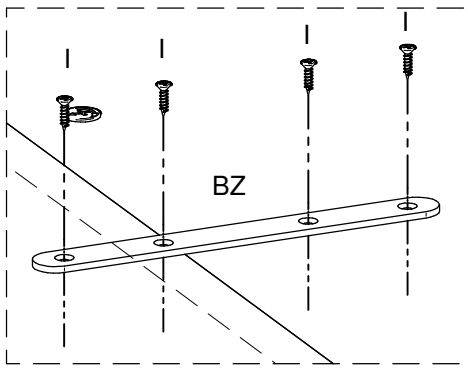
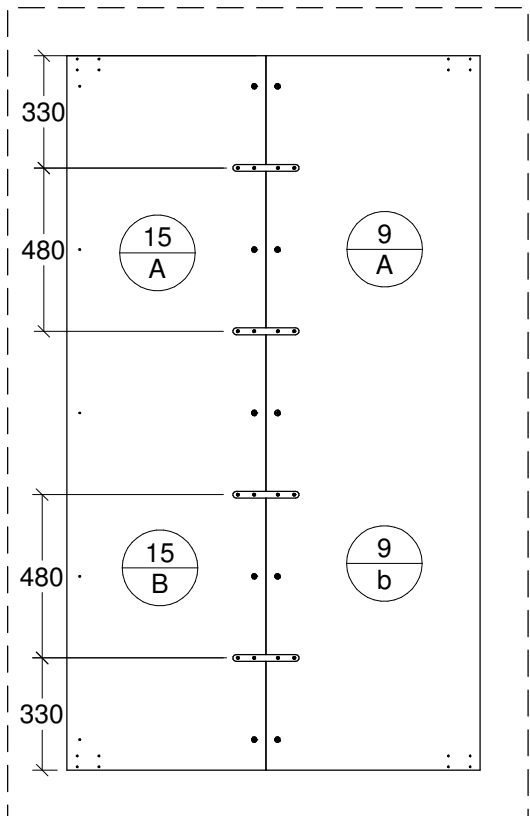

DETAIL 1

**BZ**

8x

3,5x16  
32x

39

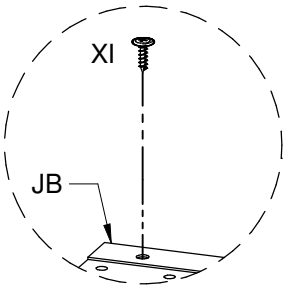
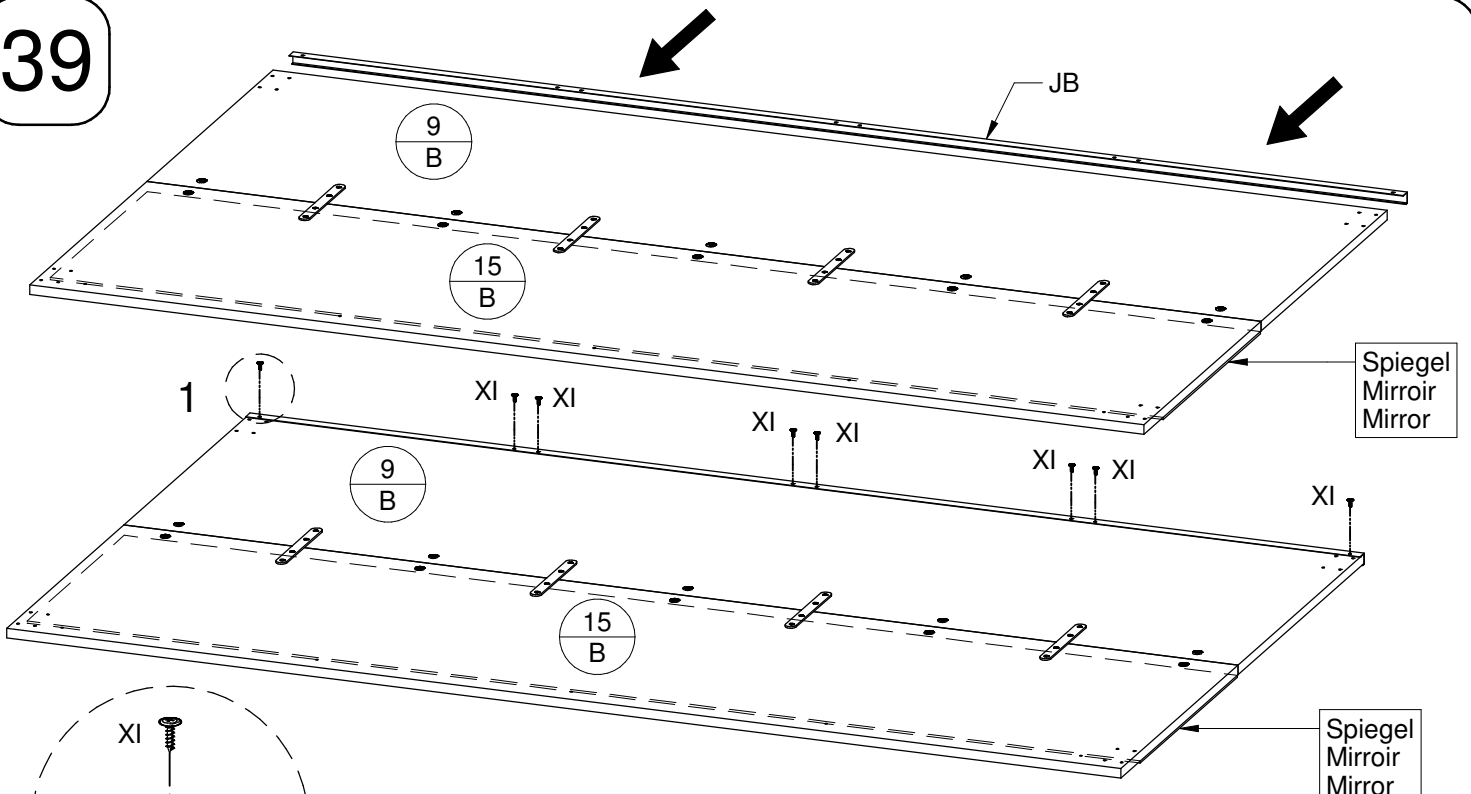

DETAIL 1

Rechtse deur  
Porte droite  
Right door

JB	XI
1x	3,5x14
	8x

40

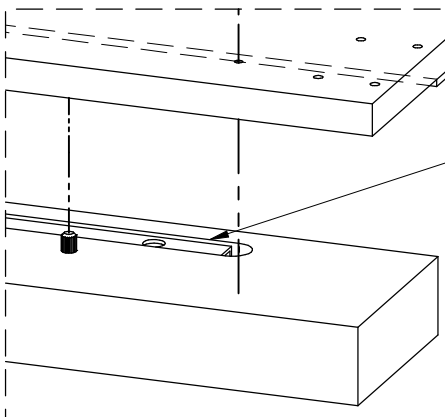
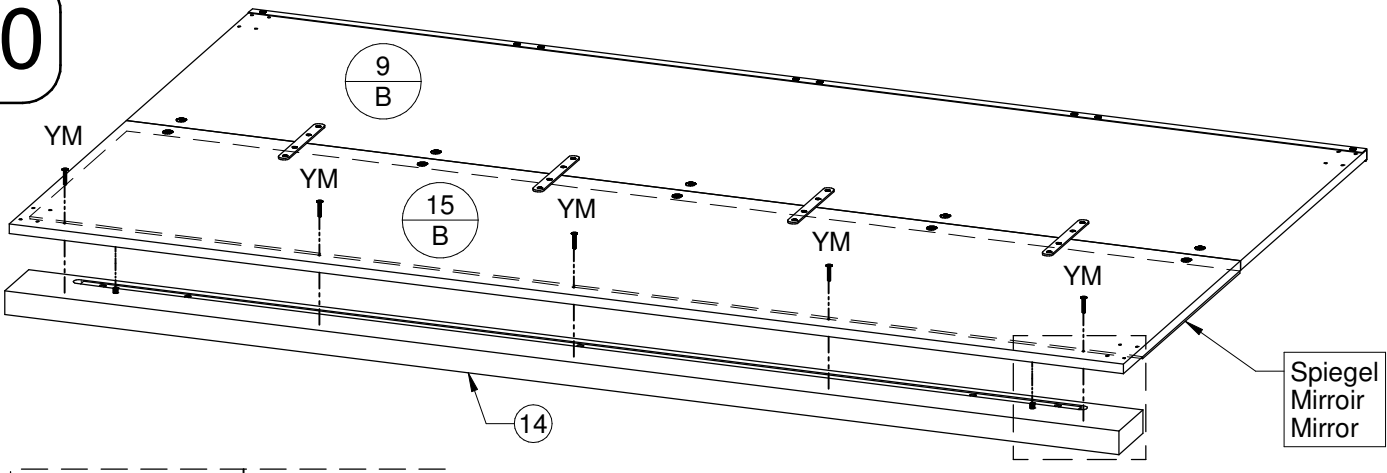

DETAIL 1

Aan dezelfde kant van de spiegel!  
Du même côté du miroir!  
On the same side of the mirror

Rechtse deur  
Porte droite  
Right door

YM	
4x30	
5x	

41

Rechtse deur  
Porte droite  
Right door

TOP

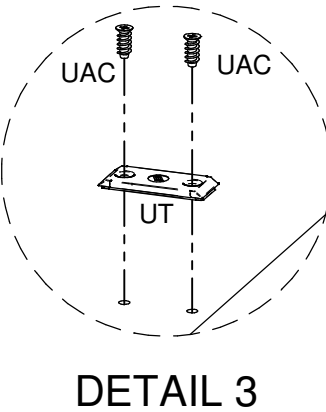
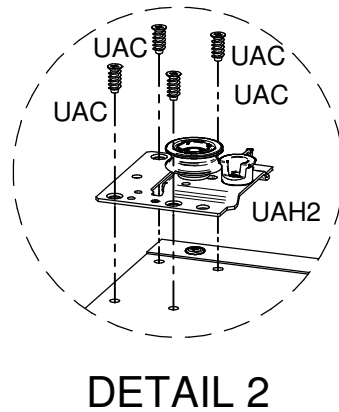
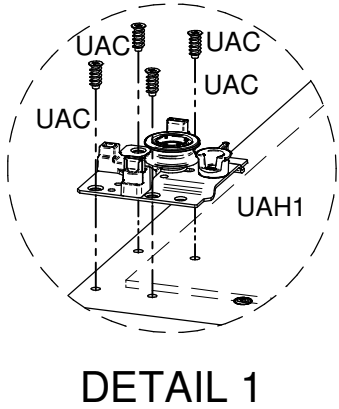
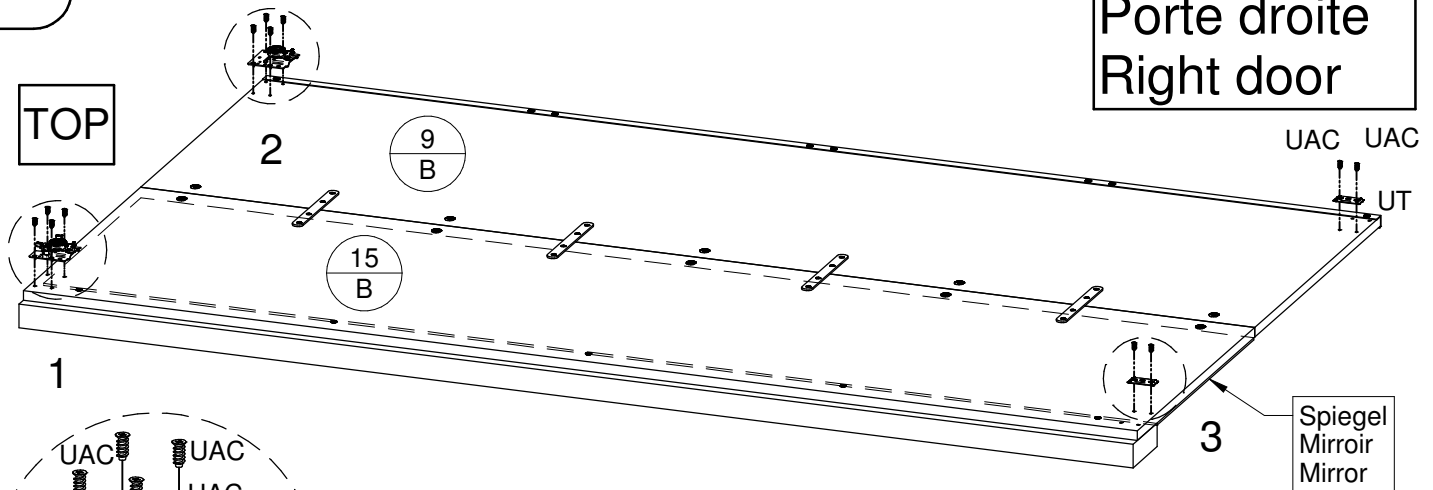

<p><b>UAC</b></p> <p>12x</p>	<p><b>UAH1</b></p> <p>1x</p>
<p><b>UAH2</b></p> <p>1x</p>	<p><b>UT</b></p> <p>2x</p>

42

Rechtse deur  
Porte droite  
Right door

TOP

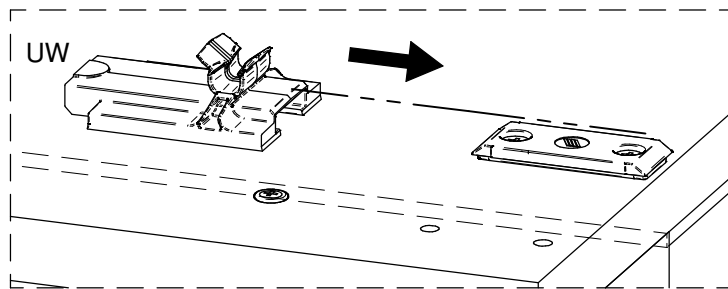
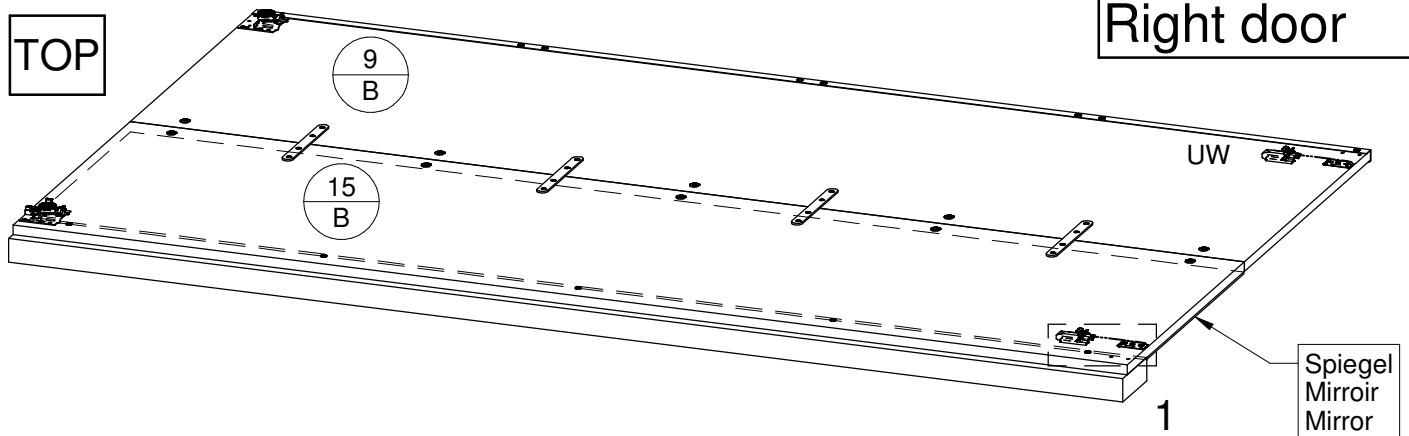

DETAIL 1

<p><b>UW</b></p> <p>2x</p>
----------------------------

43

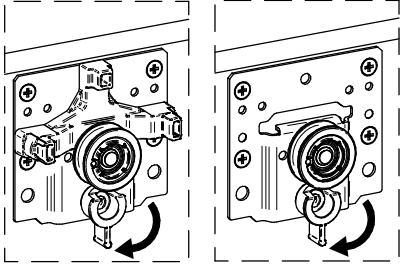

Open

Ouvert 1

Open

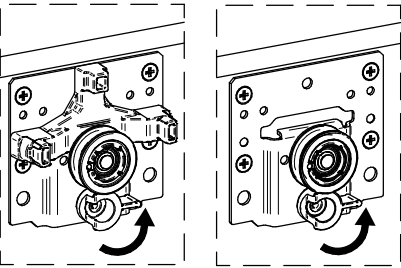

Gesloten

Fermé 4

Closed

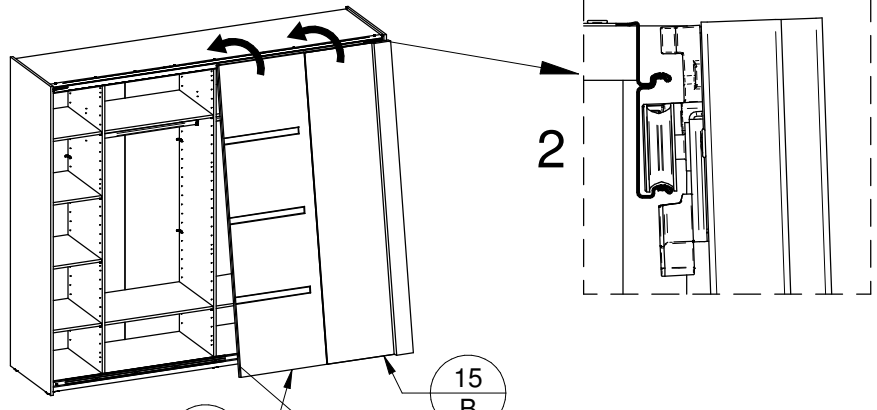

15 B

9 B

3

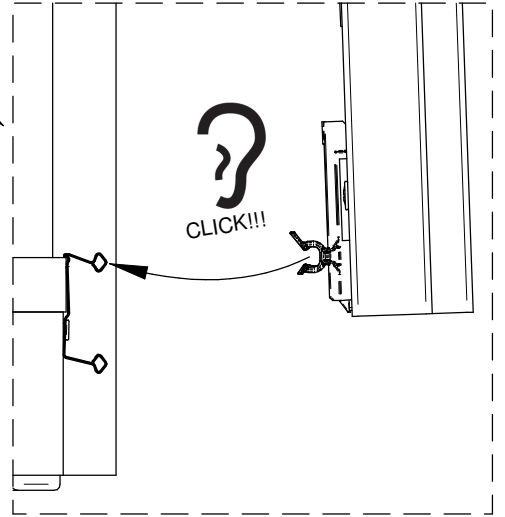

44

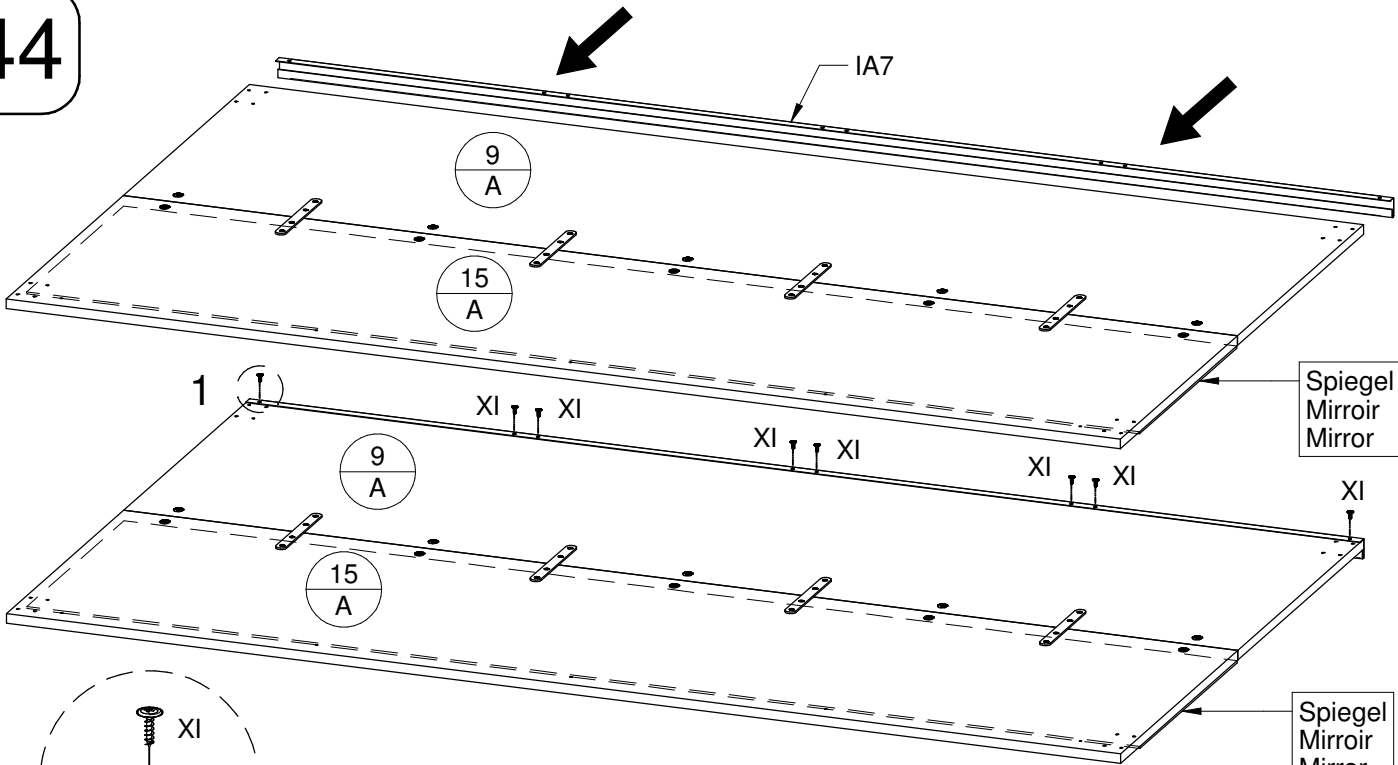

Spiegel  
Mirroir  
Mirror

Spiegel  
Mirroir  
Mirror

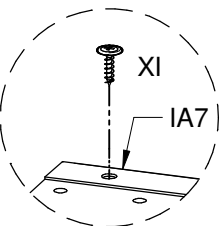

DETAIL 1

Linkse deur  
Porte gauche  
Left door

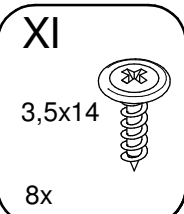
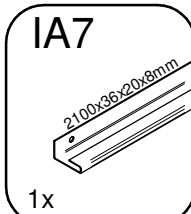

45

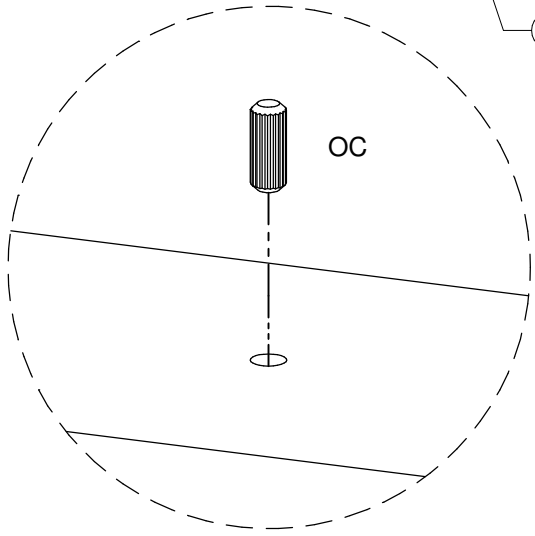
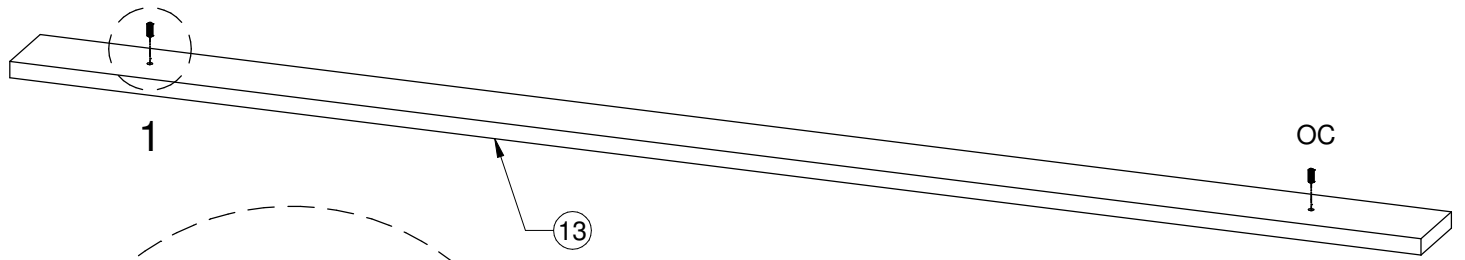

DETAIL 1

OC

8x20

2x

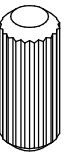

46

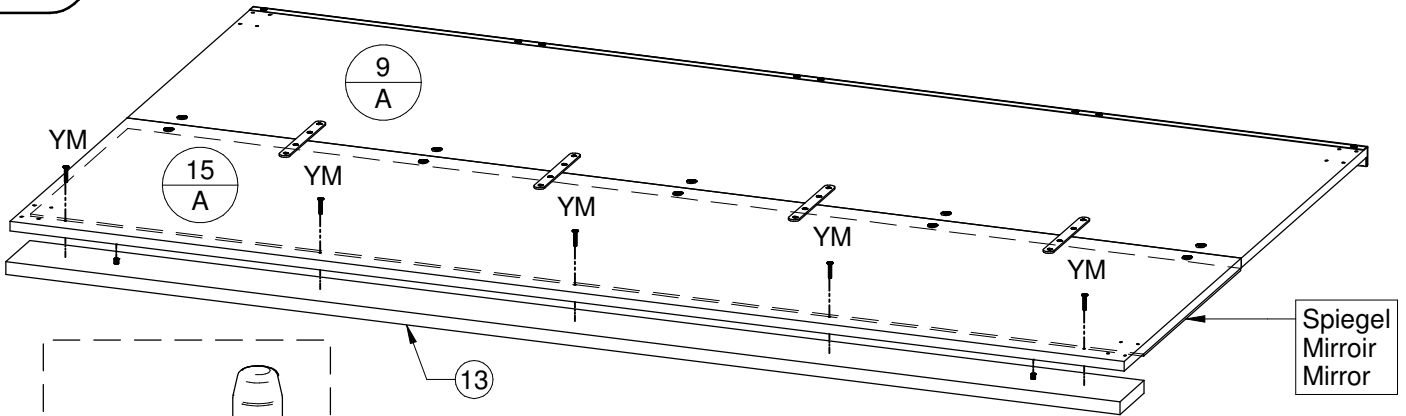

Spiegel  
Mirroir  
Mirror

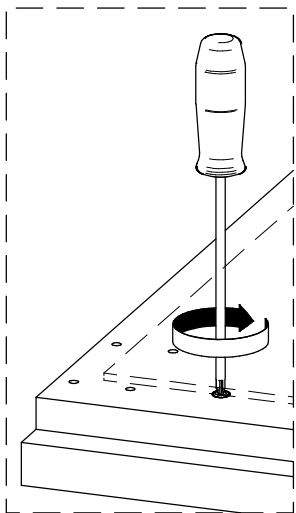

Linkse deur  
Porte gauche  
Left door

YM

4x30

5x

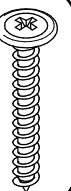

47

Linkse deur  
Porte gauche  
Left door

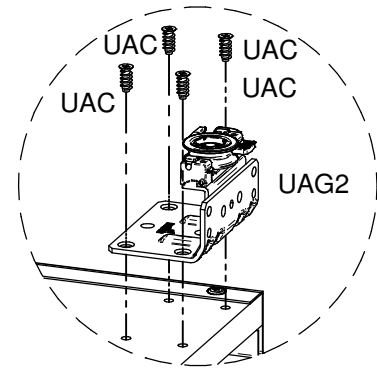
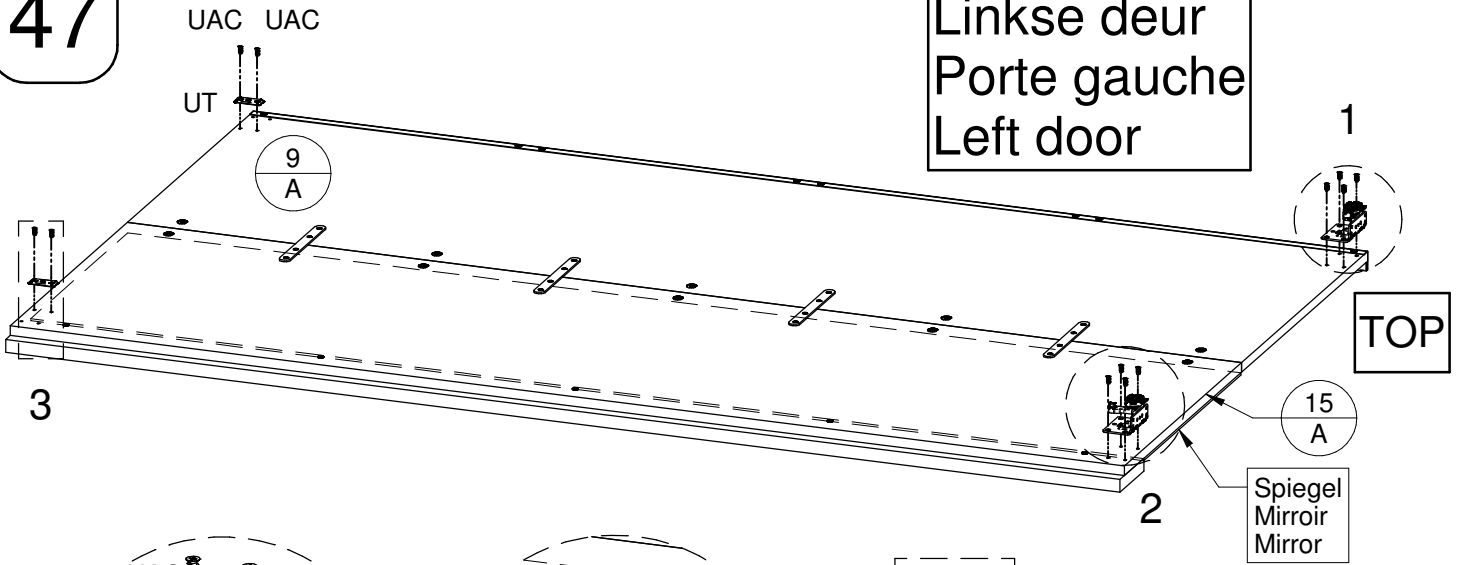

DETAIL 1

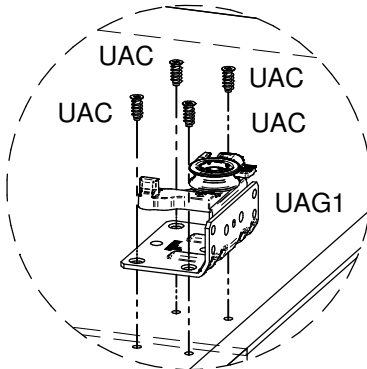

DETAIL 2

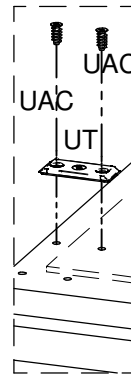

DETAIL 3

<p><b>UAC</b></p> <p>12x</p>	<p><b>UAG1</b></p> <p>1x</p>
<p><b>UAG2</b></p> <p>1x</p>	<p><b>UT</b></p> <p>2x</p>

48

Linkse deur  
Porte gauche  
Left door

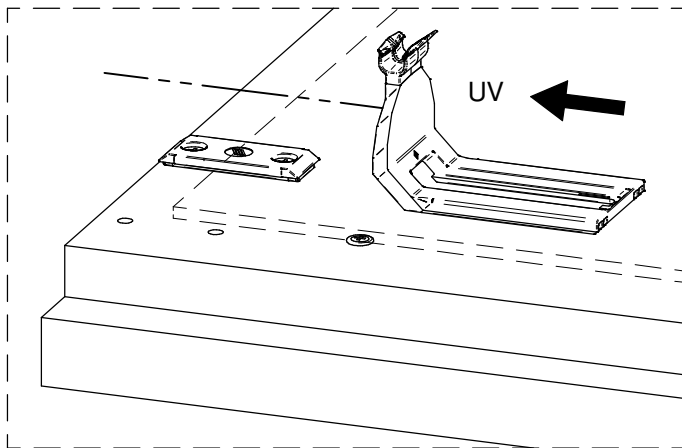
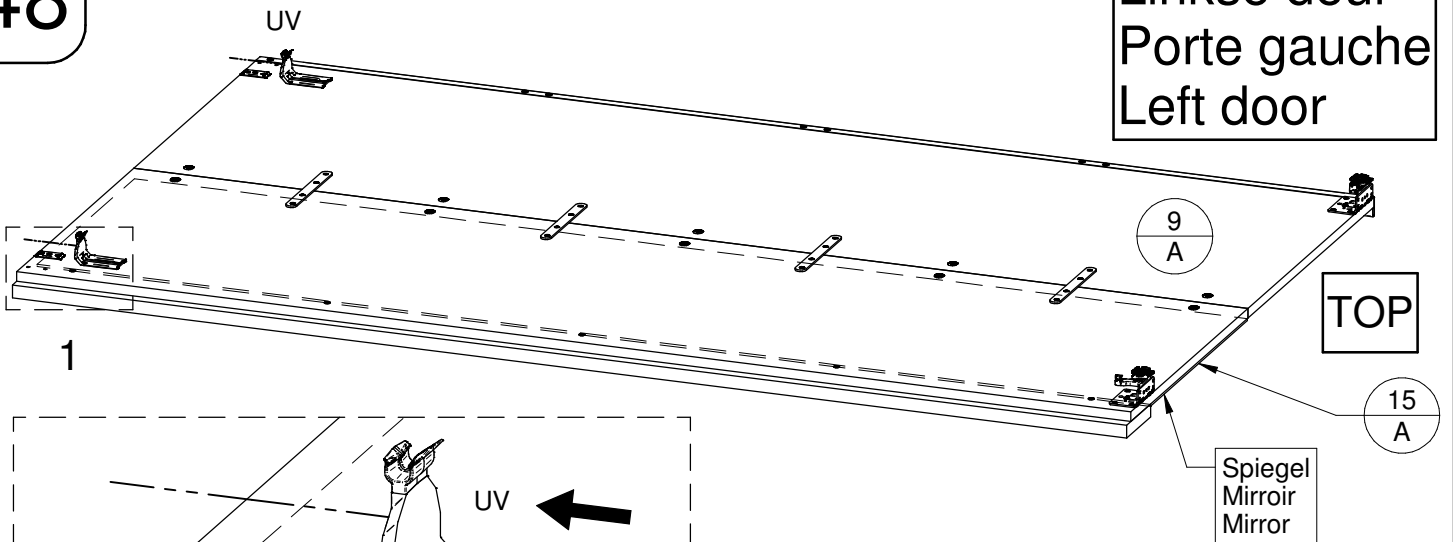



DETAIL 1

<p><b>UV</b></p> <p>2x</p>
----------------------------

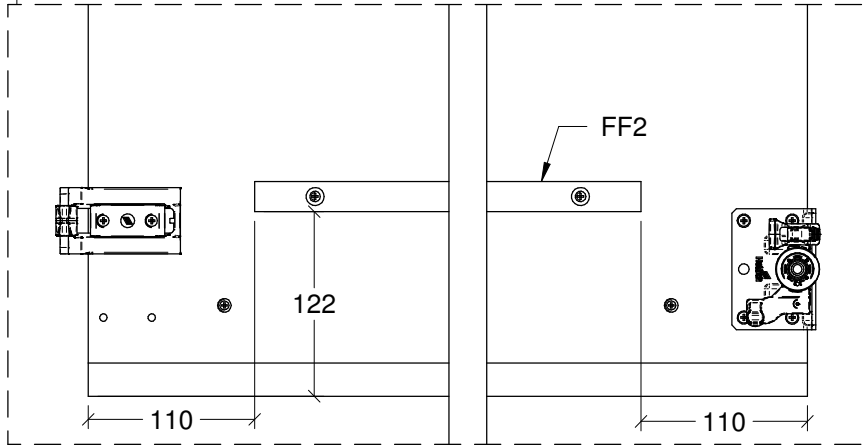
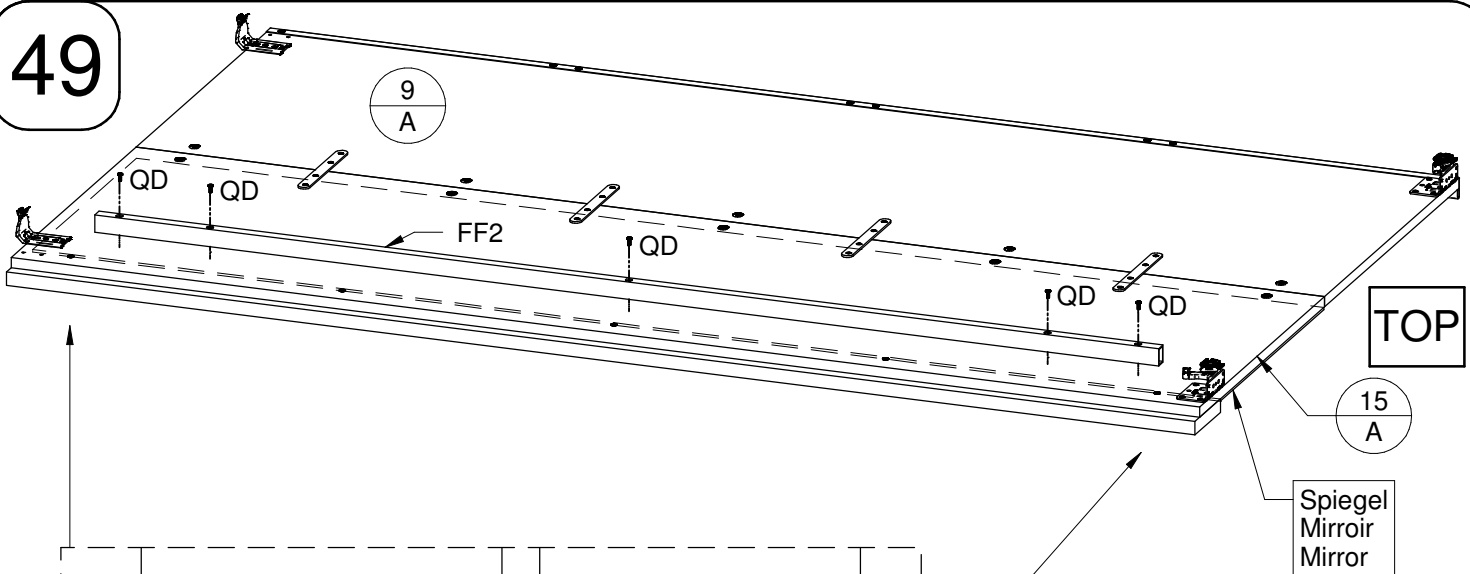
49

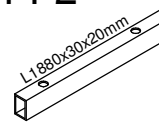

Linkse deur  
Porte gauche  
Left door

<p><b>FF2</b></p>  <p>L 1890x30x20mm</p> <p>1x</p>	<p><b>QD</b></p>  <p>3.5x16</p> <p>5x</p>
--	---

50

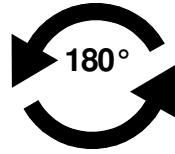

Linkse deur  
Porte gauche  
Left door

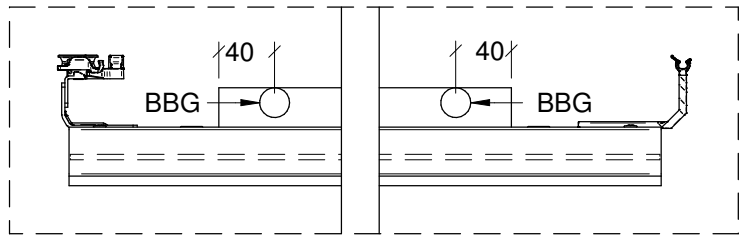
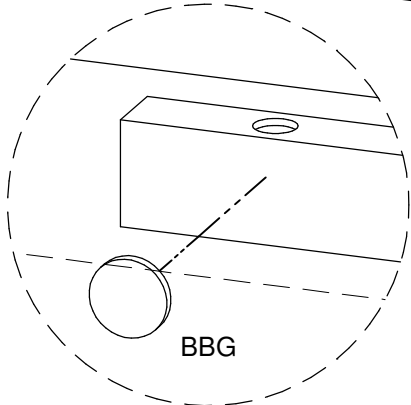
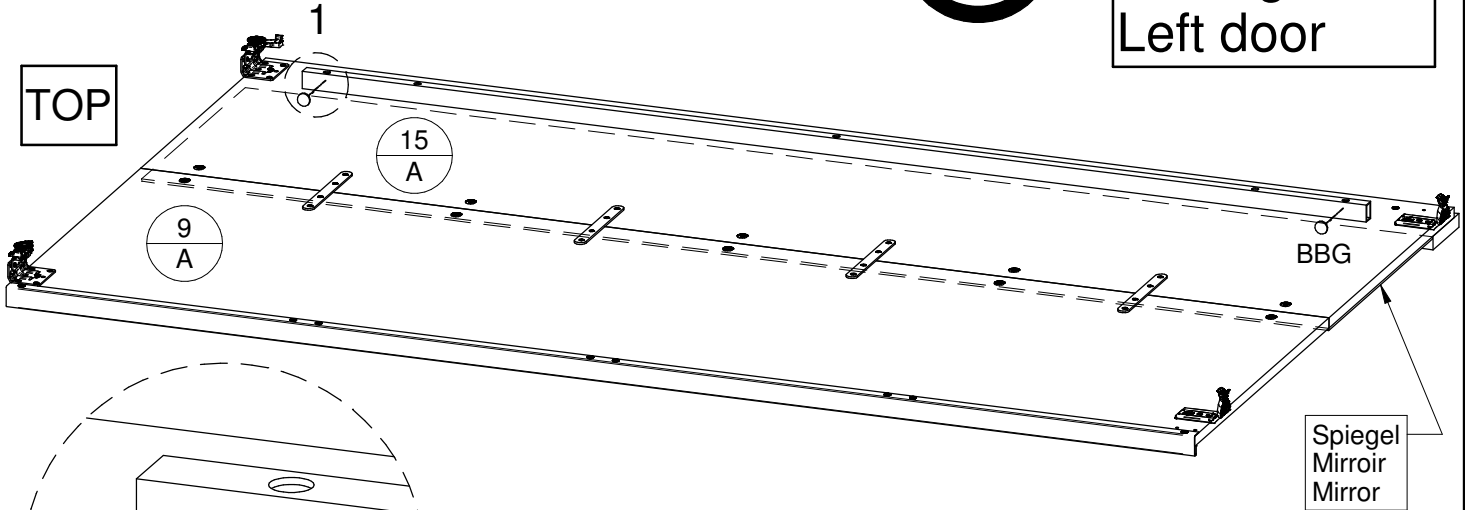

**BBG**

22mm D3

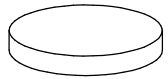

2x

51

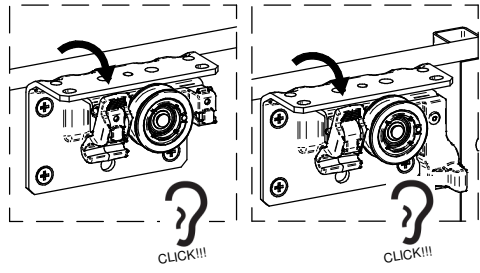

Open

Ouvert 1

Open

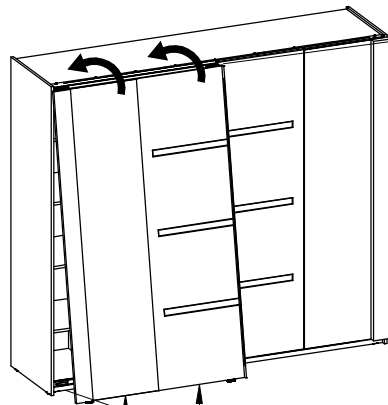

2

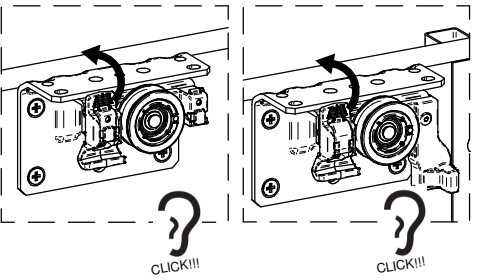
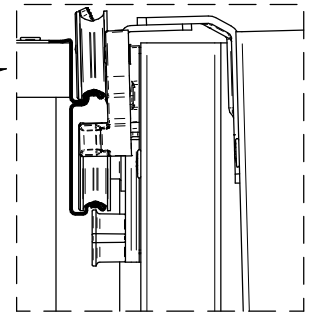

Gesloten

Fermé 4

Closed

3

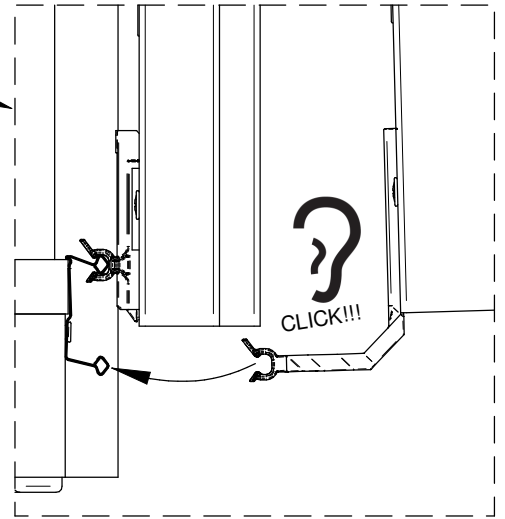

52

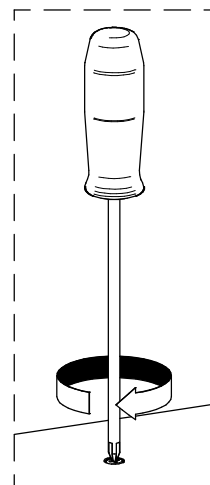
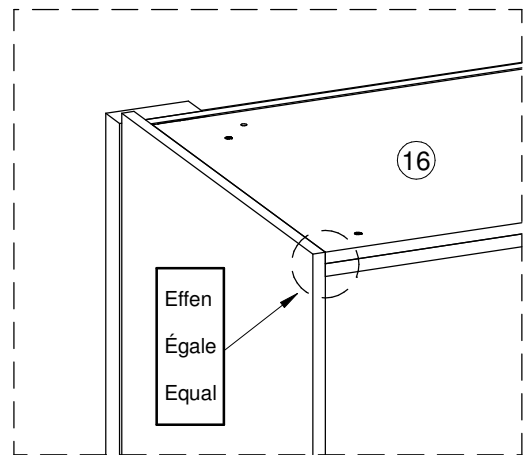
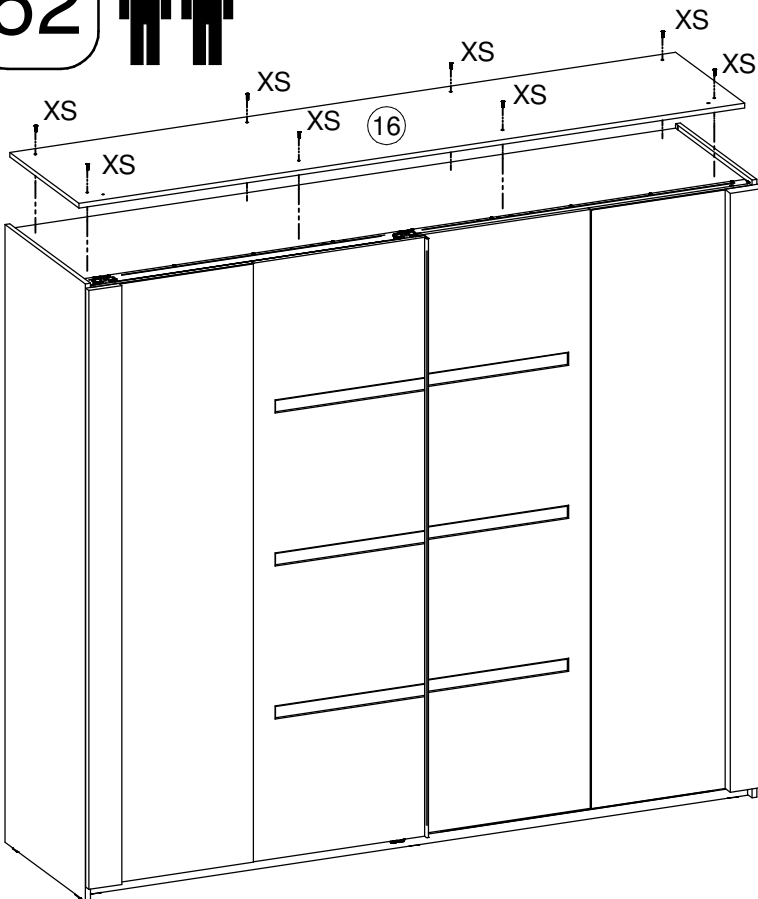
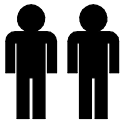

XS

4x25

8x





53

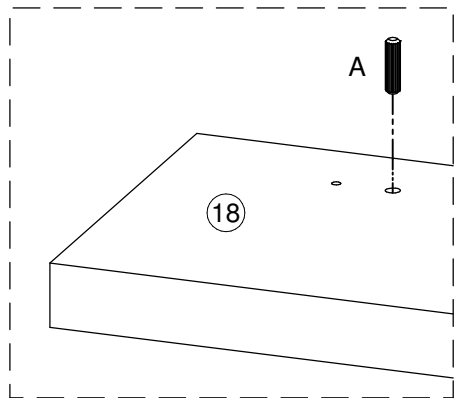
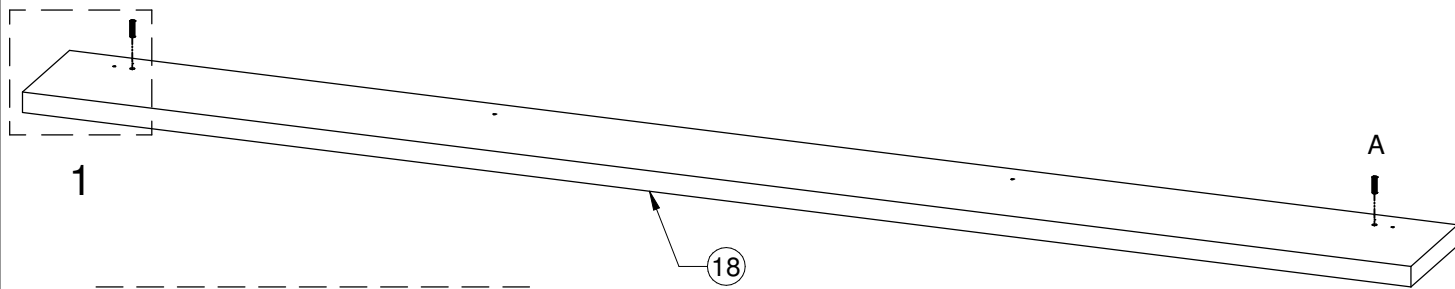

DETAIL 1

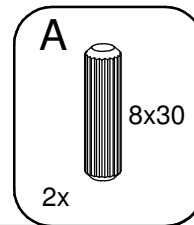

54



55

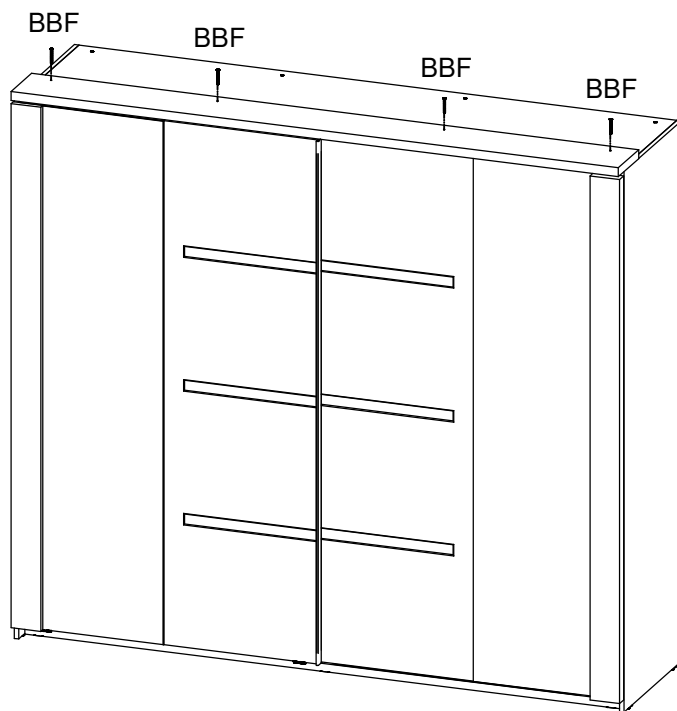
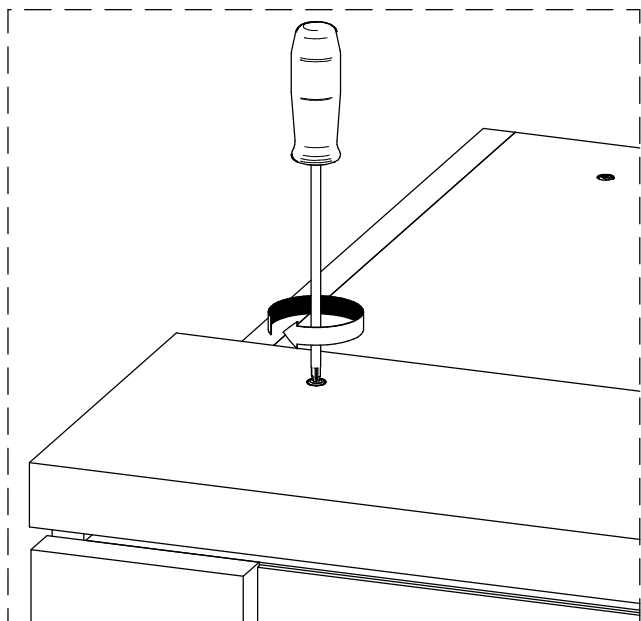

BBF

4,5x60

4x



56

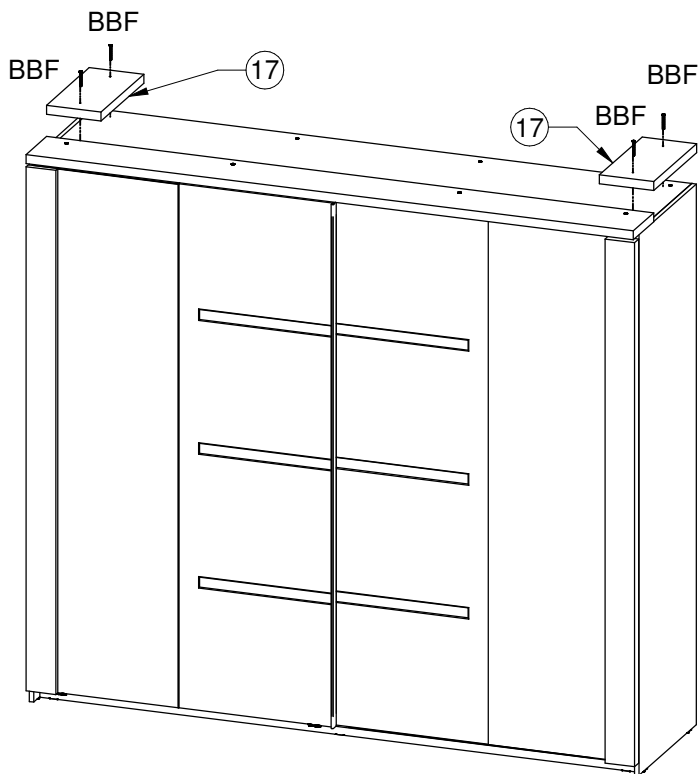
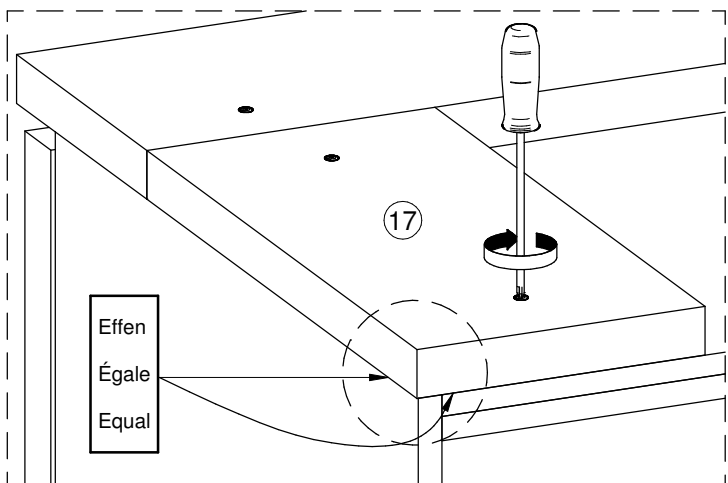

BBF

4,5x60

4x



57

1

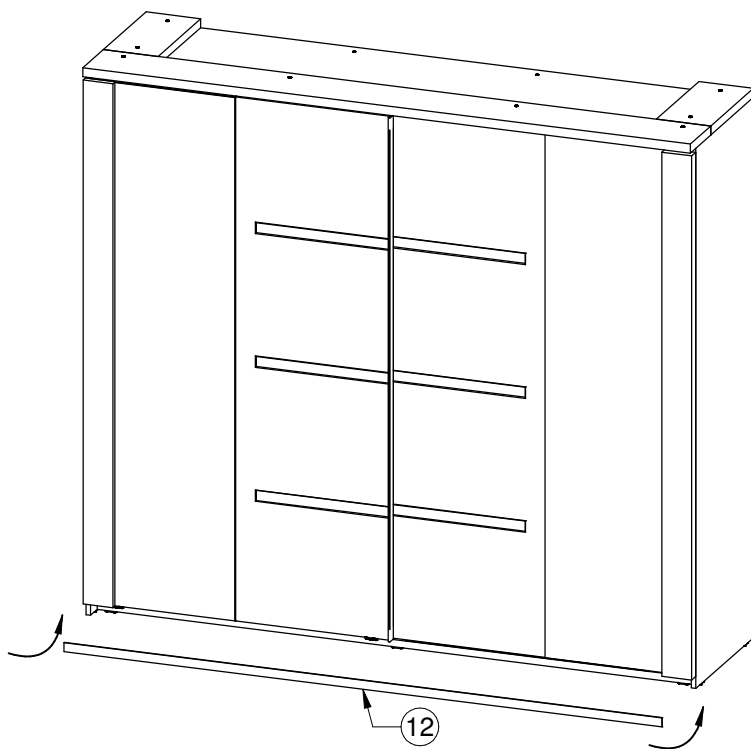
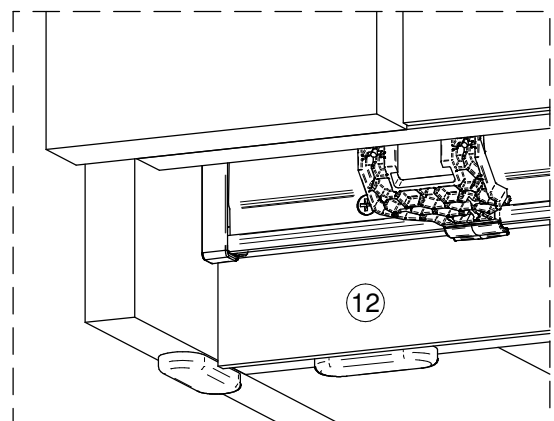
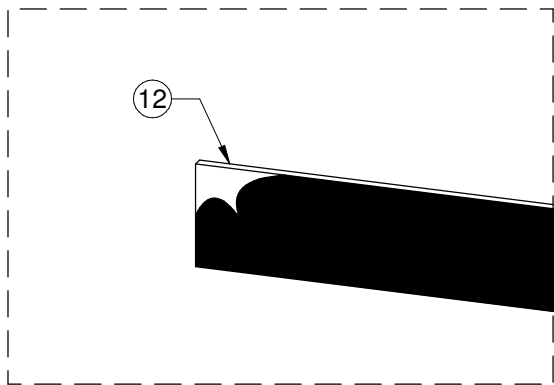

2

58

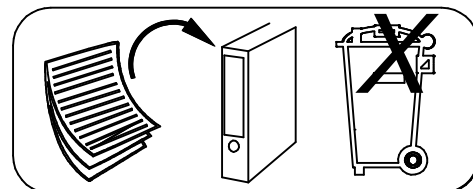
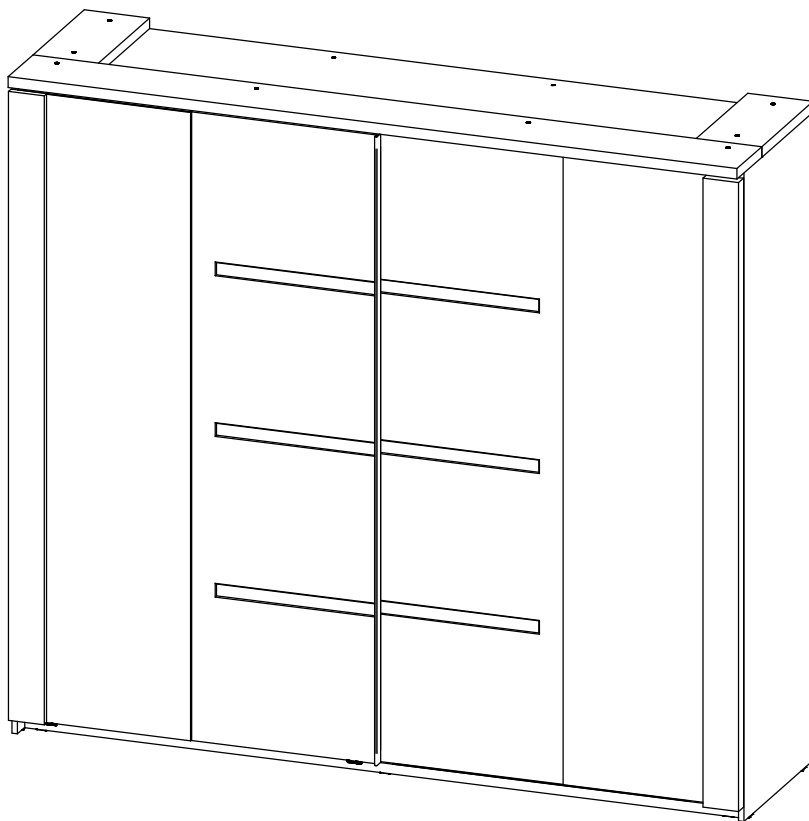



# Demontage deuren Démontage des portes Disassembly of doors

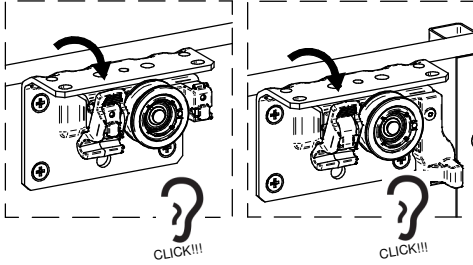

Open

Ouvert **1**

Open

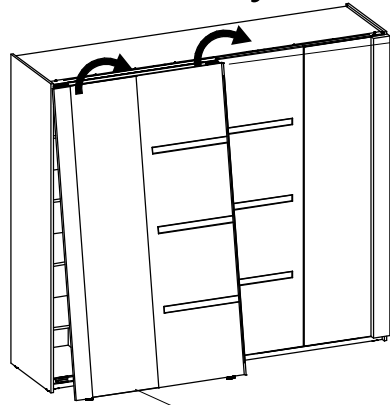

3

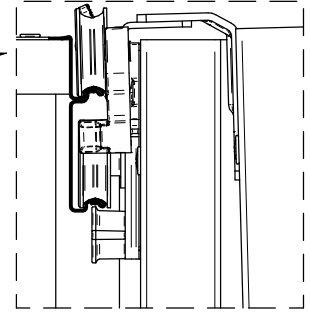

2

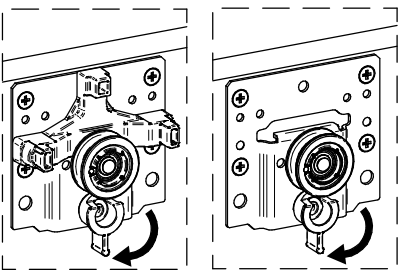
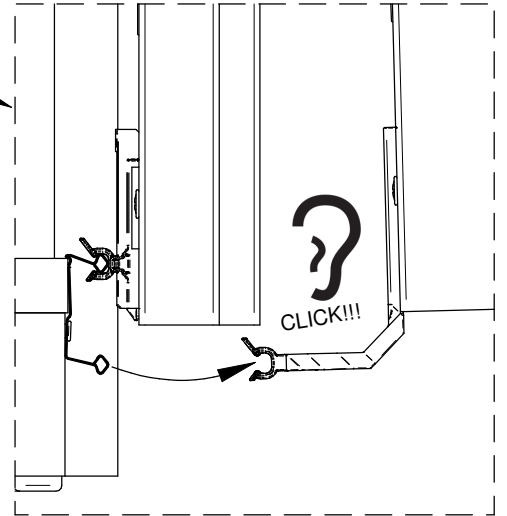

Open

Ouvert **4**

Open

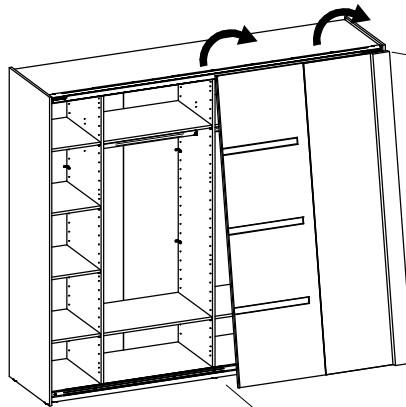

6

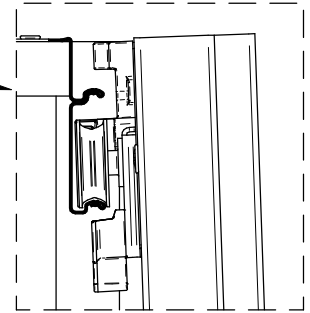

5

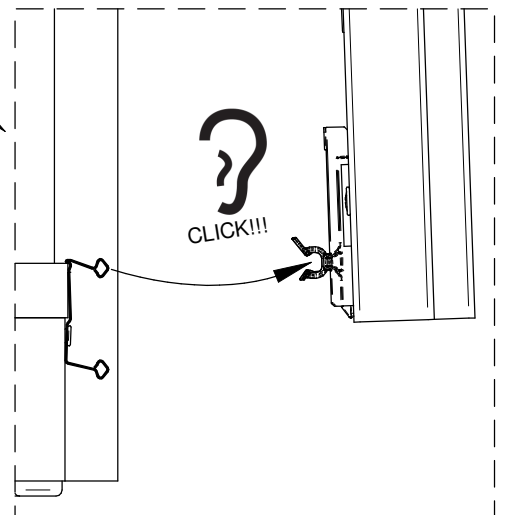

# Onderhoud - Entretien - Maintenance

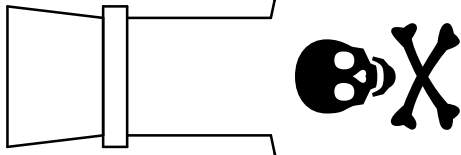

Oplosmiddel  
Reinigingsmiddel  
Verdunner  
Chemische producten  
Boenwas

NL

Solvant  
Détergent  
Diluant  
Produits chimiques  
Cirage

FR

Solvent  
Cleaner  
Thinner  
Chemical products  
Wax

GB

NL

**Algemene informatie:** Voor tafels geldt geen hete pannen, theeglazen en waxinelichtjes op de ondergrond plaatsen. Gebruik hiervoor altijd een onderzetter. Het meubel leegmaken en niet verslepen op de vloer bij eventuele verplaatsing.

**Onderhoud:** Met licht vochtige doek reinigen en hierna direct droog wrijven. Vocht op het bovenblad direct opnemen. De meubels zijn niet voor vochtige ruimten bestemd. Gebruik nooit een schuurspons, schuurmiddel, amoniak, oplosmiddel, reinigingsmiddel, verdunner, chemische producten, boenwas of producten zoals Pledge-was of dergelijke. Montage tekening opbergen.

**Service na verkoop:** Voor service na verkoop, ga naar uw leverancier met deze montage tekening.

**Garantie:** Het niet naleven van deze onderhoudsvoorschriften doet de garantie met onmiddellijke ingang verloren gaan.

**L'information générale:** Ne mettez jamais des casseroles chaudes, des verres à thé sur la surface des tables. Veuillez utiliser des sous verres. Videz le meuble avant tout déplacement. Portez le meuble et non pas le pousser sur le sol!

**Entretien:** Utilisez un chiffon légèrement humide et sèche aussitôt. Toute trace de liquide doit être enlevé immédiatement.

Les meubles ne sont pas adaptés aux pièces humides. N'utilisez jamais des éponges abrasives, amoniac, solvant, détergent, diluant, produits chimiques, cirage, des produits d'entretien comme Pledge etc.... . Notice de montage à conserver.

**Service après-vente:** Pour tout service après-vente, rendez vous au magasin avec cette notice.

**Garantie:** Nous vous informons qu'en cas de non respect aux prescriptions sus - mentionnés que la garantie expire immédiatement.

FR

GB

**General information:** Never put hot items on the table tops!

Empty furniture before moving it and do not drag the furniture over the floor.

**Maintenance:** Clean with slightly wet moistened cloth, wipe dry immediately. Wipe off wetness at once.

Not suited for humid locations. Never use solvent, cleaner, thinner, chemical products or wax. Retain manual instruction.

**For the after sales:** For the after sales, go back to the shop with this assembly instruction.

**Guarantee:** Attention in case of non respect to the above prescriptions the warranty expires immediately.

# Dienst na verkoop

Beste klant,

Wij danken u voor de aankoop van dit meubel. Ondanks de zorg die wij besteden aan de productie en verpakking van onze meubelen, kan het voorkomen dat er iets ontbreekt of beschadigd is.

Is dit het geval vragen wij u om via bijgaand formulier uw DNV te melden aan de winkel waar u uw meubel heeft aangekocht.

Volg volgende onderstaande stappen in geval van schade:

1. Een foto van het complete meubel (onderdeel)
2. Een detailfoto van het probleem

Op die manier kunnen wij u zo vlug mogelijk helpen om uw probleem op te lossen.

Met vriendelijke groeten,

# Service après vente

Cher client,

Nous vous remercions pour l'achat de ce meuble. Malgré tout les soins que nous consacrons à la production et le conditionnement de nos meubles, il est possible que quelque chose est manqué ou endommagé.

Si c'est le cas, nous vous demandons d'utiliser le formulaire ci-joint pour déclarer votre plainte au magasin où vous avez acheté vos meubles.

En cas de dommages, nous vous demandons également de prendre les photos suivants et de nous les envoyer:

1. Une photo du mobilier complet (partie)
2. Une photo de détail du problème

De cette façon, nous pouvons vous aider le plus vite possible afin de résoudre votre problème.

Sincèrement,

# Service after sale

Dear customer,

Thank you for purchasing this piece of furniture. Despite the care we take in the production and packaging of our furniture, it is possible that something is missing or damaged.

If this is the case, we ask you to use the enclosed form to report your SAS to the store where you purchased your furniture.

Follow the steps below in case of damage:

1. A photo of the complete furniture (part)
2. A detailed photo of the problem

In this way we can help you solve your problem as quickly as possible.

With best regards,

# Formulier DNV - Formulaire SAV - Form SAS

**Terug te sturen naar uw winkel / A renvoyer à votre magasin**

**/ Send back to the shop**

Datum / Date :

## Uw gegevens / Vos donnees / Your data

Naam / Nom / Name :

Adres / Adresse / Address :

E-mail :

Tel. / GSM / Mobile :

## Gegevens over het probleem / Donnees sur le problème / Information about the problem

Datum aankoop / Date d'achat / Date of purchase :

Naam model en meubelonderdeel :

Nom modèle et partie du meuble:

Name model and piece of furniture:

Onderdeelnr. of colli nr. (zie montageplan) :

N° de pièce ou coli (voir le plan de montage):

Number piece or coli number (view assemble plan):

Kleur of stof / Couleur ou tissu / Color or cloth:

Digitale foto's in bijlage / Photos digitales en annexe / Digital photos attached: **YES/ NO**

Gedetailleerde omschrijving van het probleem:

Description détaillée du problème:

Detailed description of the problem: