

EN AZ İKİ KİŞİ İLE KURUNUZ!

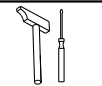

TWO PERSON ASSEMBLY REQUIRED!



Rev. 01 / 25.02.2020

TR: Keyifli ve kolay bir montaj için:

Garanti şartlarının geçerli olması için kurulum şemasındaki sıraya uygun olarak montaj yapılması gerekmektedir. Hatasız ve daha kolay montaj için tüm parçaları önce geniş ve düz zemine diziniz. Şemada gösterilen parça listesi ile ürün kutusundan çıkan parçaları karşılaştırınız. Montajı ürün kolisi üzerinde veya sert ve çizici olmayan bir zeminde, parça kutusundan çıkan "L" şeklindeki demir çubuk (alyan anahtarı), yıldız tornavida ve çekiç kullanara yapınız. Kurulumu tamamladıktan sonra montaj şemasını saklayınız.

EN: For an easy and enjoyable assembly: Please read the assembly chart completely. Remove all the parts from the carton box and place them on a smooth surface. Make sure you have exactly all the parts and tools listed in on the chart ready. Start assembling the products following the steps on the chart. Use only the tools provided within the product, a screwdriver and a hammer. Please keep the assembly chart for future reference.

DE: Für eine einfache und unterhaltsame Montage:

Bitte lesen Sie die Montagetablelle vollständig durch. Entfernen Sie alle Teile aus der Kartonverpackung und legen Sie sie auf eine glatte Oberfläche. Stellen Sie sicher, dass Sie genau alle Teile und Werkzeuge bereit haben, die in der Tabelle aufgeführt sind. Beginnen Sie mit der Montage der Produkte gemäß den Schritten in der Tabelle. Verwenden Sie nur die im Produkt enthaltenen Werkzeuge sowie einen Schraubendreher und einen Hammer. Bitte bewahren Sie die Montagetablelle zu späteren Nachschlagen auf.

FR: Pour un montage simple et facile: Veuillez lire l'intégralité du manuel de montage. Retirez toutes les pièces de l'emballage et placez-les sur une surface lisse. Assurez-vous d'avoir toutes les pièces et tous les outils répertoriés dans le manuel de montage. Commencez à assembler les pièces en suivant les étapes du manuel. Utilisez uniquement les outils fournis avec le produit, un tournevis et un marteau. Veuillez conserver précieusement le manuel de montage.

ES: Para un montaje fácil y agradable:

Por favor, lea la tabla de montaje por completo. Retire todas las piezas del embalaje de la caja de cartón y colóquelas sobre una superficie lisa. Asegúrese de tener listas todas las piezas y herramientas enumeradas en la tabla. Comience a ensamblar los productos siguiendo los pasos en la tabla. Use solo las herramientas proporcionadas dentro del producto y un destornillador y un martillo. Guarde la tabla de ensamblaje para referencia futura.

IT: Per un assemblaggio facile e divertente. Si prega di leggere completamente la tabella di montaggio. Rimuovere tutte le parti dall'imballaggio della scatola di cartone e posizionarle su una superficie liscia. Assicurarsi di avere esattamente tutte le parti e gli strumenti elencati nella tabella pronti. Inizia ad assemblare i prodotti seguendo i passaggi sulla tabella. Utilizzare solo gli strumenti forniti all'interno del prodotto e un cacciavite e un martello. Conservare la tabella di assemblaggio per riferimenti futuri.

GR: Για εύκολη και ευχάριστη συναρμολόγηση:

Παρακαλούμε διαβάστε πλήρως το διάγραμμα συναρμολόγησης. Αφαιρέστε όλα τα εξαρτήματα από τη συσκευασία του κιβωτίου και τοποθετήστε τα σε μια ομαλή επιφάνεια. Βεβαιωθείτε ότι έχετε έτοιμα όλα τα μέρη και τα εργαλεία που αναφέρονται στο γράφημα. Ξεκινήστε τη συναρμολόγηση των προϊόντων ακολουθώντας τα βήματα του γραφήματος. Χρησιμοποιείτε μόνο τα εργαλεία που παρέχονται μέσα στο προϊόν και ένα κατασβίδι και ένα σφυρί. Διατηρήστε το διάγραμμα συναρμολόγησης για μελλοντική αναφορά.

RO: Pentru o asamblare ușoară și plăcută: Vă rugăm să citiți graficul de asamblare complet. Scoateți toate părțile din ambalajul cutiei de carton și așezați-le pe o suprafață netedă. Asigurați-vă că aveți exact toate piesele și instrumentele enumerate în grafic. Începeți asamblarea produselor urmând pașii din grafic. Folosiți numai instrumentele furnizate în interiorul produsului și o surubelniță și o ciocan. Vă rugăm să păstrați diagrama de asamblare pentru referințe viitoare.





RU: Для легкого и приятного монтажа:

Пожалуйста, прочитайте инструкции по установке полностью. Удалите все части из картонной коробки и поместите их на ровную поверхность. Пожалуйста, убедитесь, что у вас есть ровно все указанных части и инструменты на инструкции по установке готовы. Начните сборку деталей выполнив следующие действия на инструкции по установке. Используйте только входящий в комплект инструментов с помощью отвертки и молотка. Пожалуйста, держите инструкцию по установке для дальнейшего использования.

ARB: من أجل تركيب بسيط و ممتع الرجاء قراءة ورقة التركيب بكاملها تخليص جميع القطع من العلبة الكرتون و وضعهم على سطح أملس. حضر جميع القطع و الأجزاء المطلوبة في القائمة بكاملها. المستعمل فقط الأجزاء المتوفرة مع المنتج بلاضافة الى المطرقة و مفك البراغي الرجاء الاحتفاظ بأوراق التركيب لاستعمالها في وقت لاحق

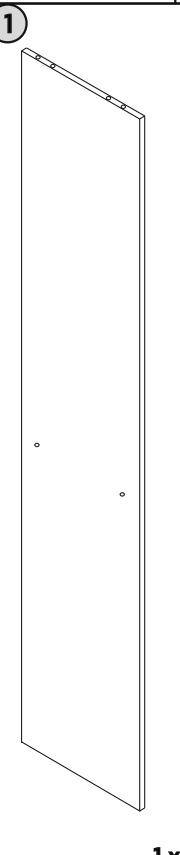
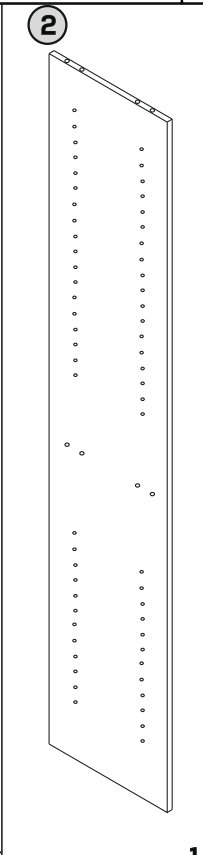
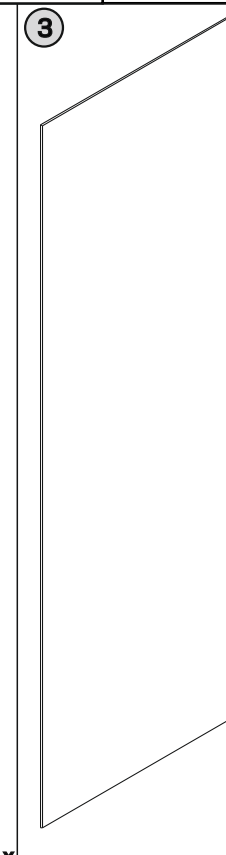
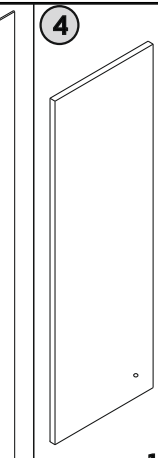
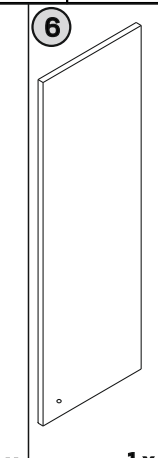
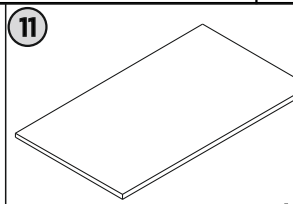
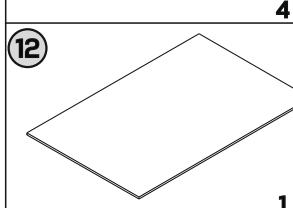
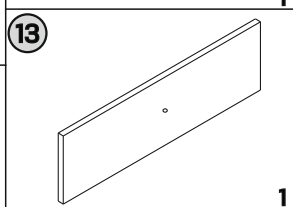
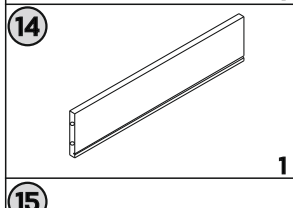
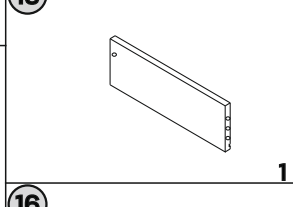
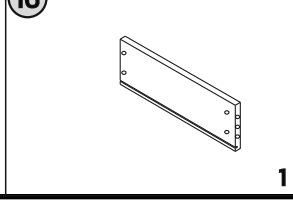
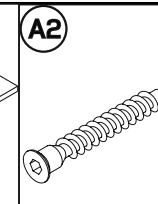
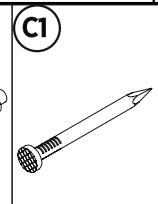
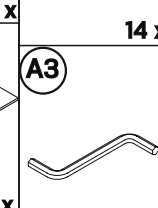
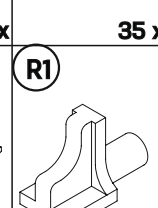
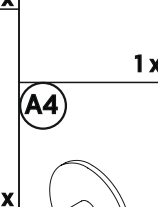
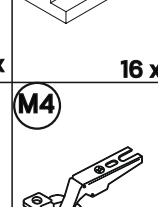
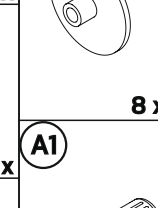
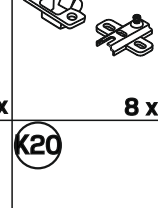
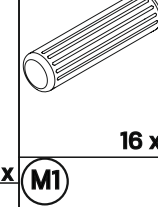
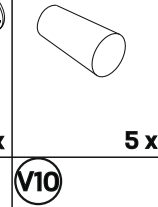
QC 0310221324 - 05

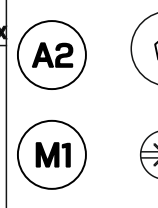
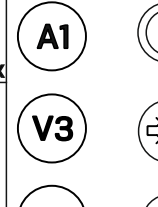
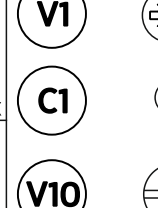
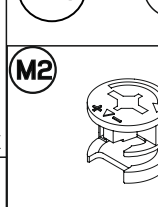
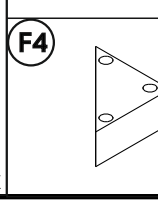
ADR-441

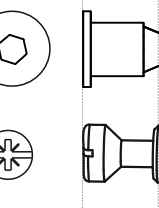
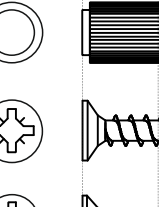
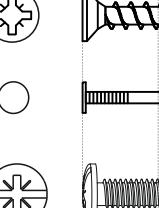
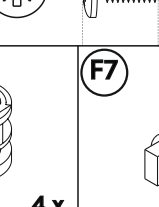
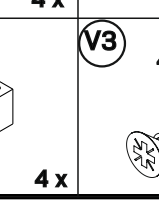
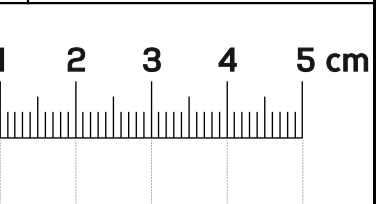
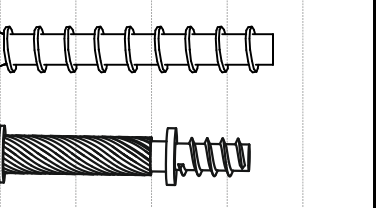
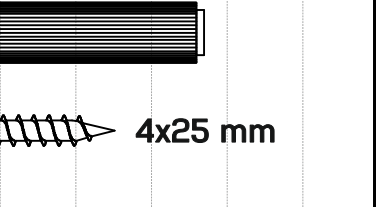
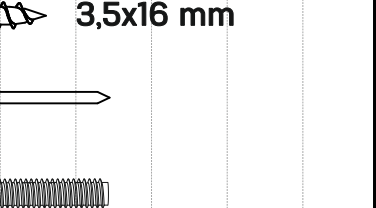
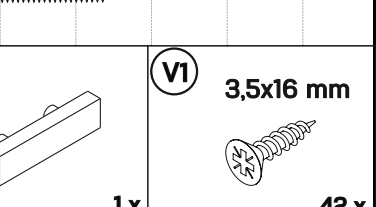
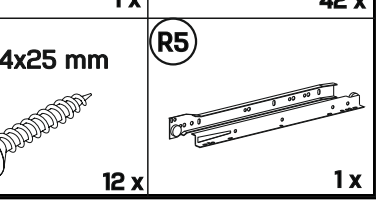
 1x	 1x	 1x	 1x	 1x	 4x	 1x	 1x	 1x	 1x	 1x	 14x	 35x	 1x	 16x	 8x	 8x	 16x	 5x	 4x	 5x	 4x	 1x	 3,5x16 mm	 4x	 4x25 mm	 12x	 42x	 1x	 3,5x16 mm	 1x	 3,5x16 mm	 1x	 0 1 2 3 4 5 cm	 4x25 mm	 3,5x16 mm	 3,5x16 mm	 3,5x16 mm	 3,5x16 mm
---	--	--	---	---	--	--	--	---	--	--	--	--	---	--	---	---	---	--	---	---	---	---	--	--	--	--	--	---	--	--	--	---	---	--	--	---	--	--

1

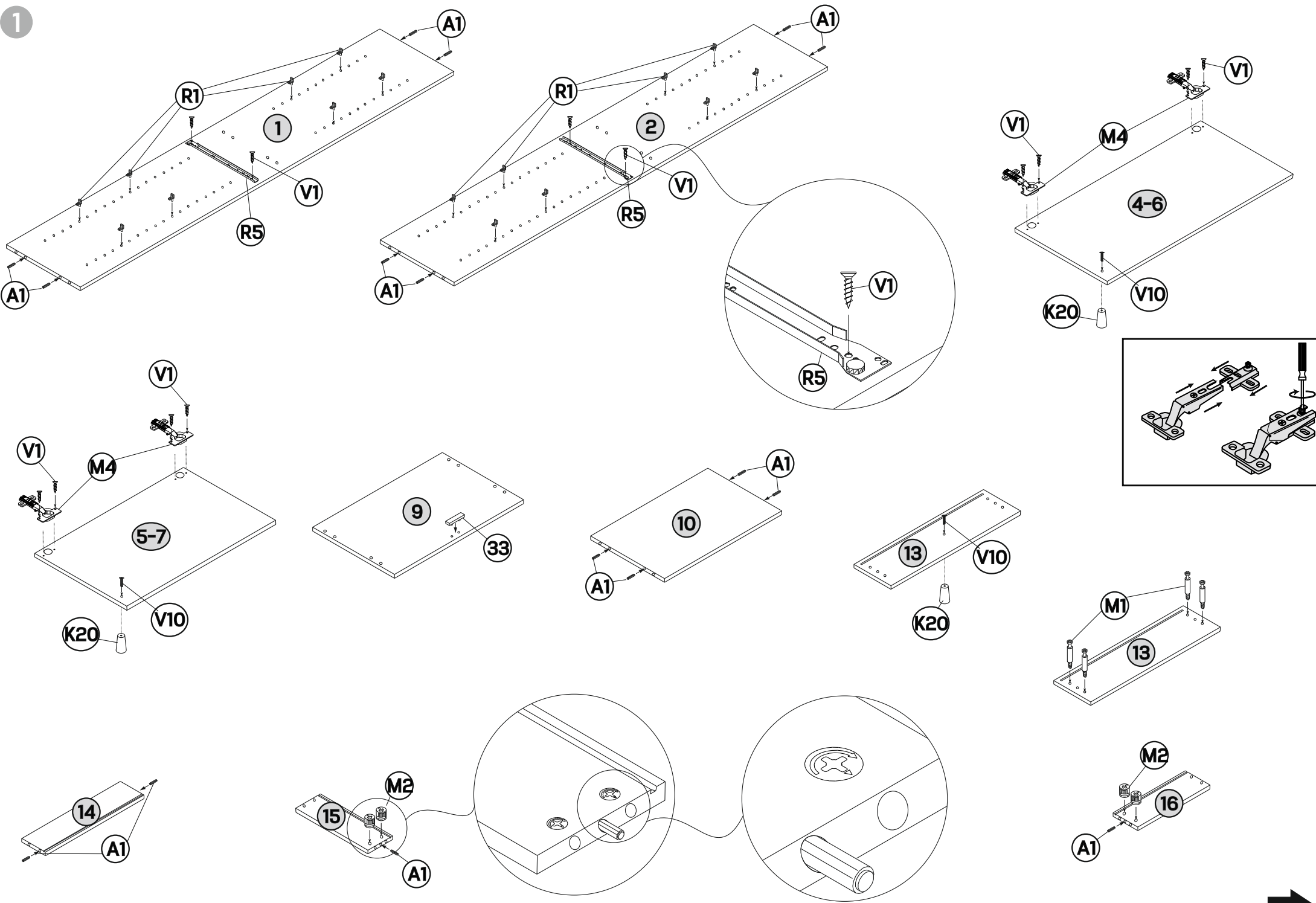

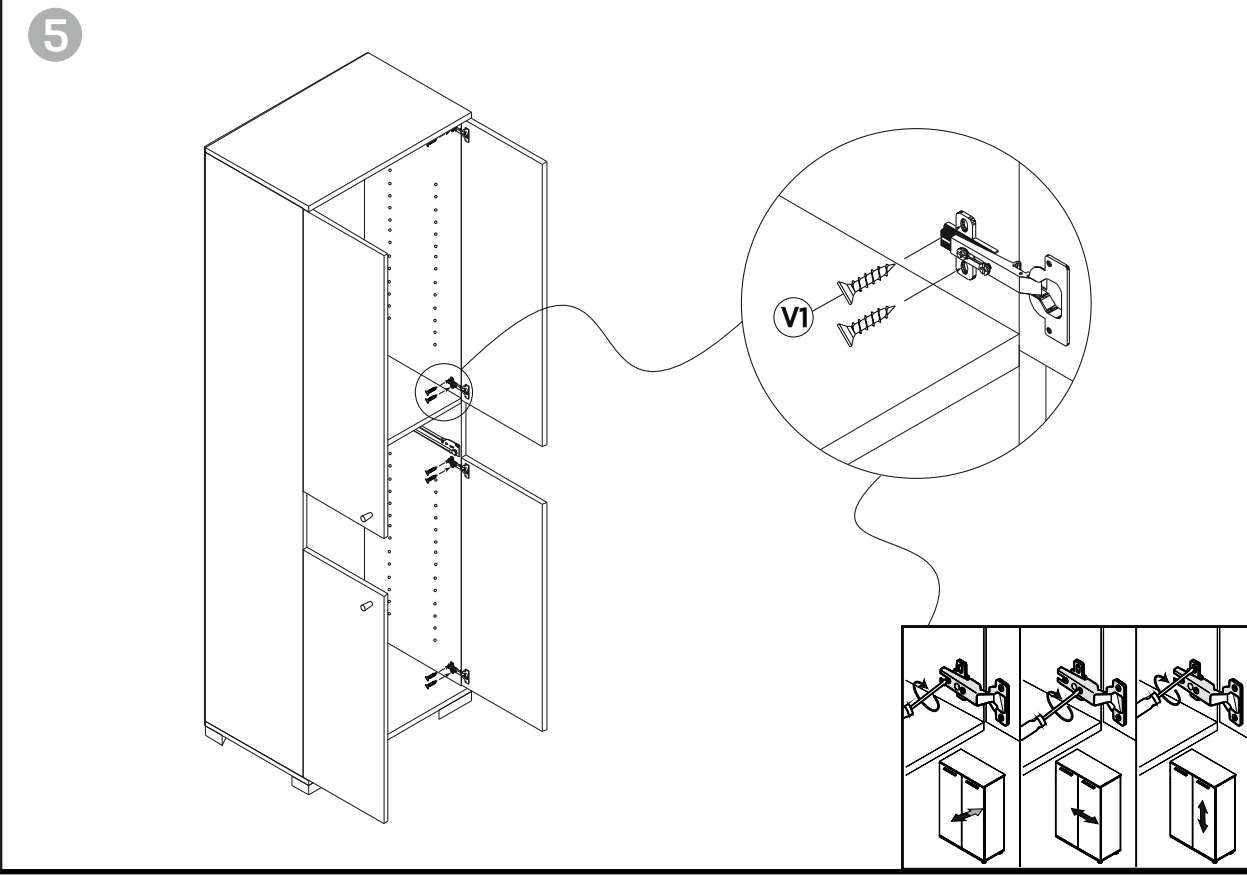
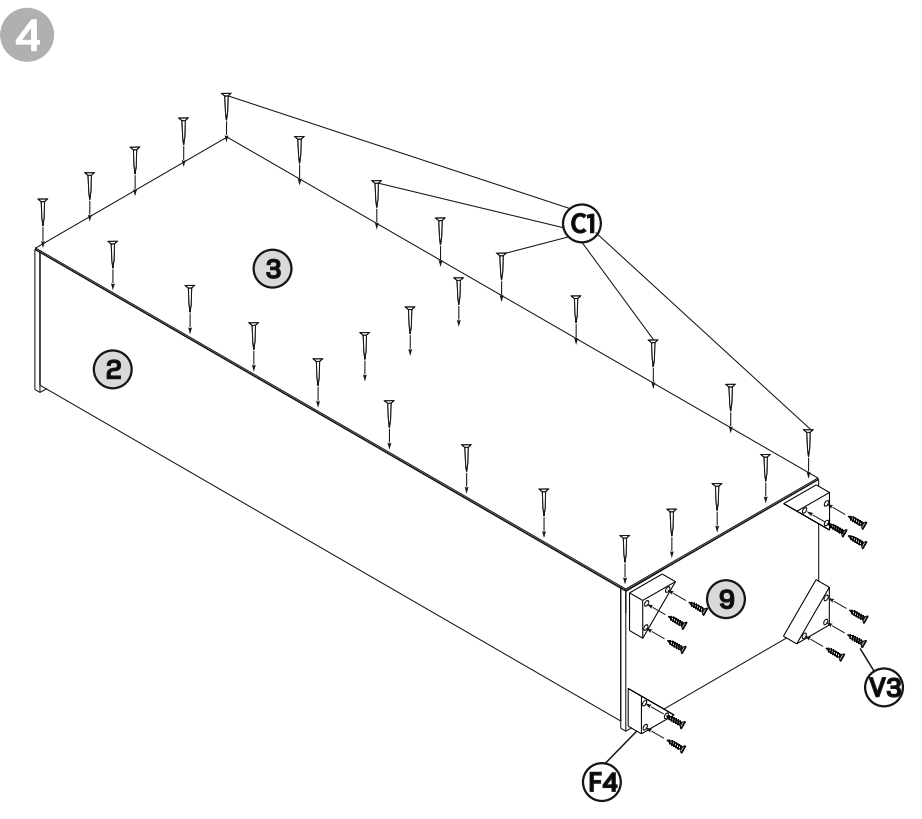
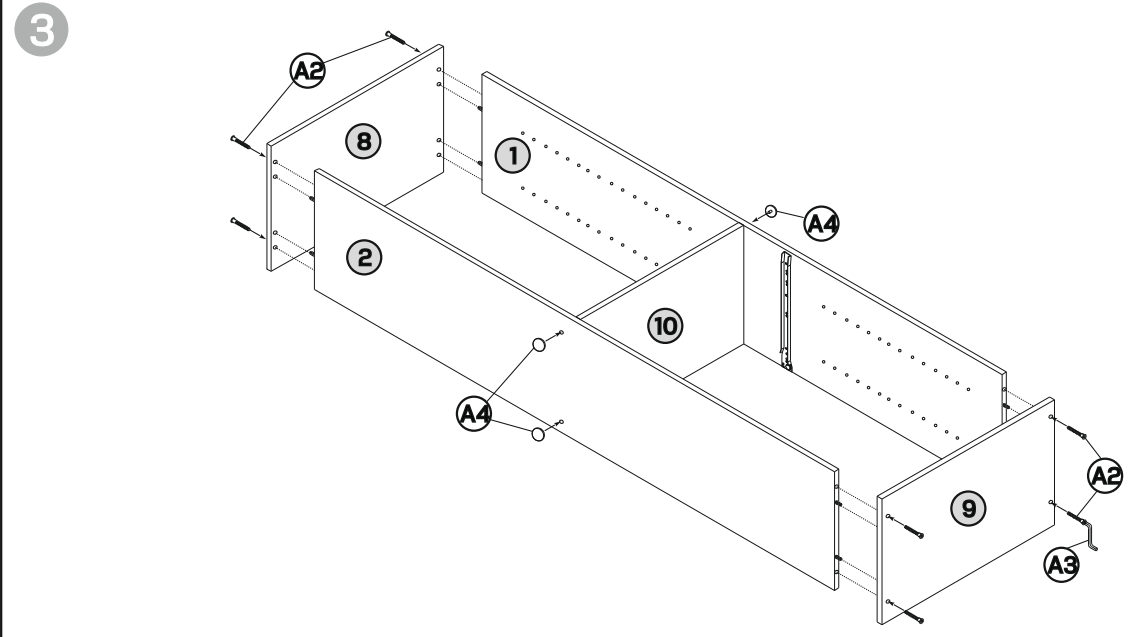
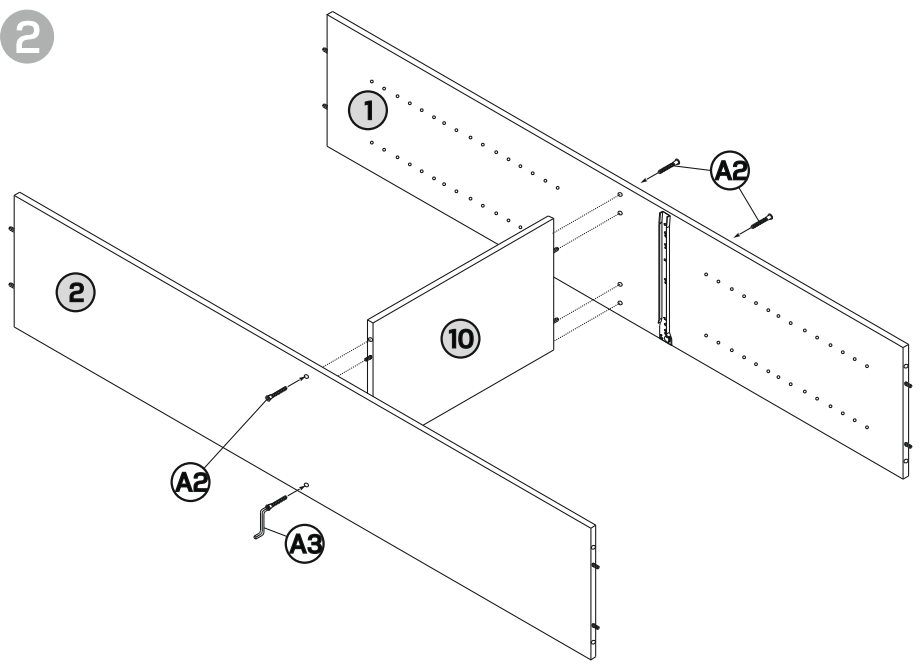

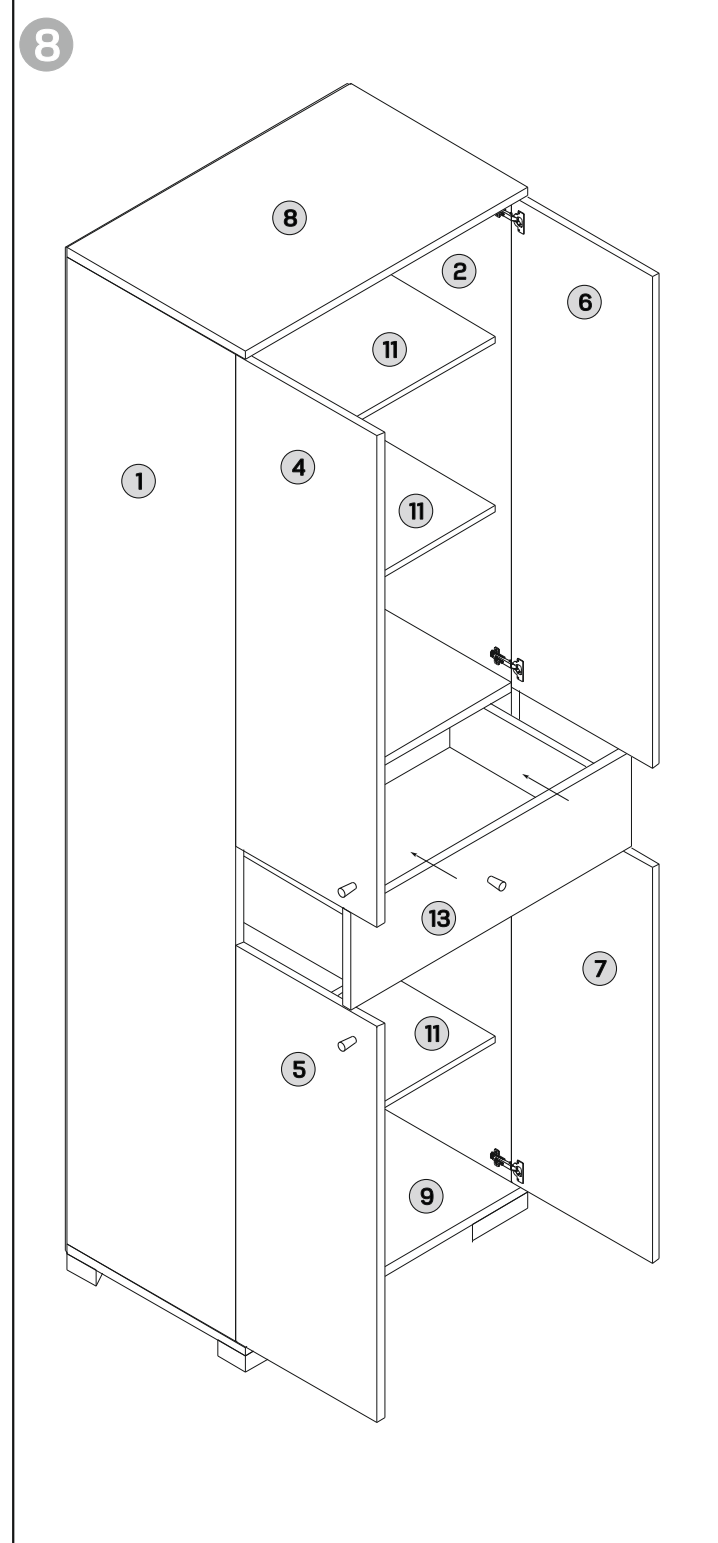
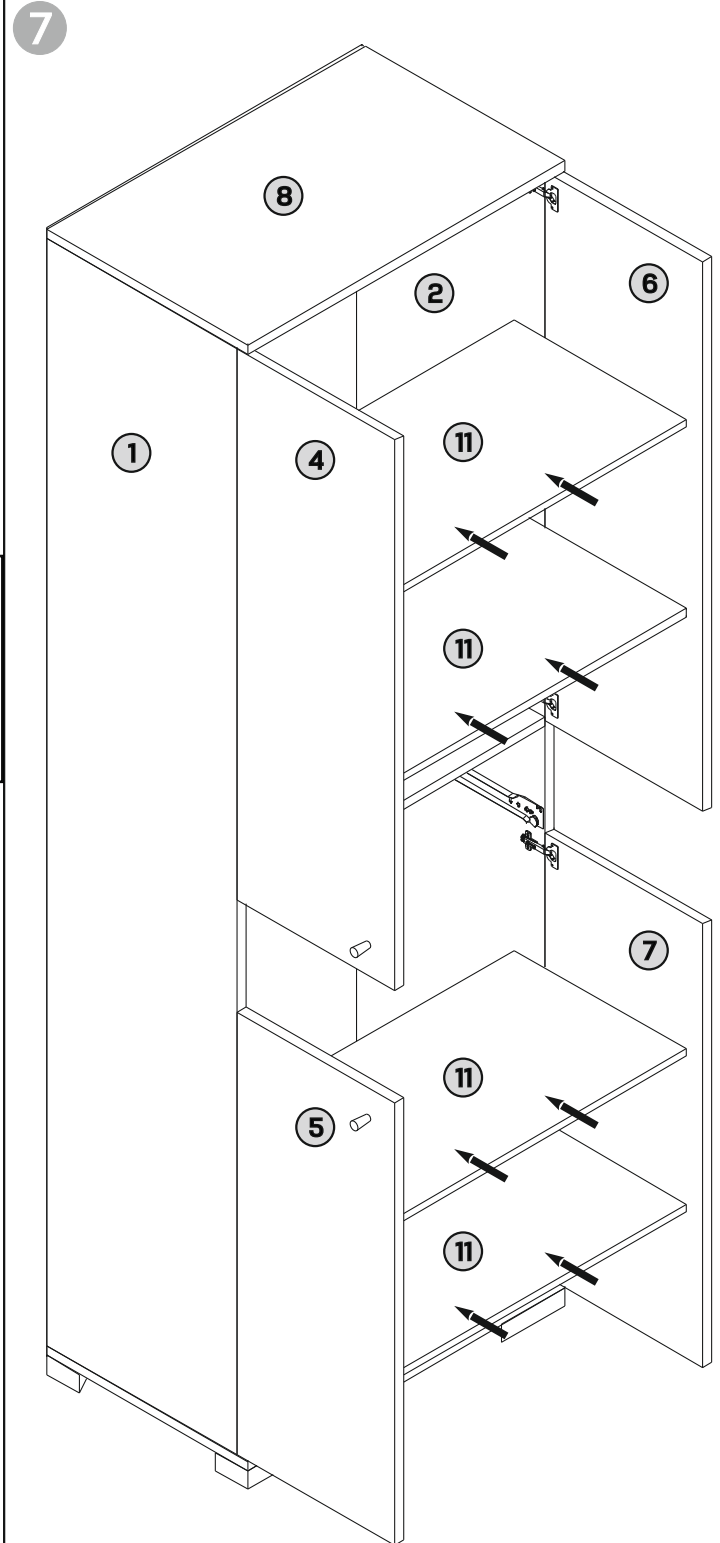
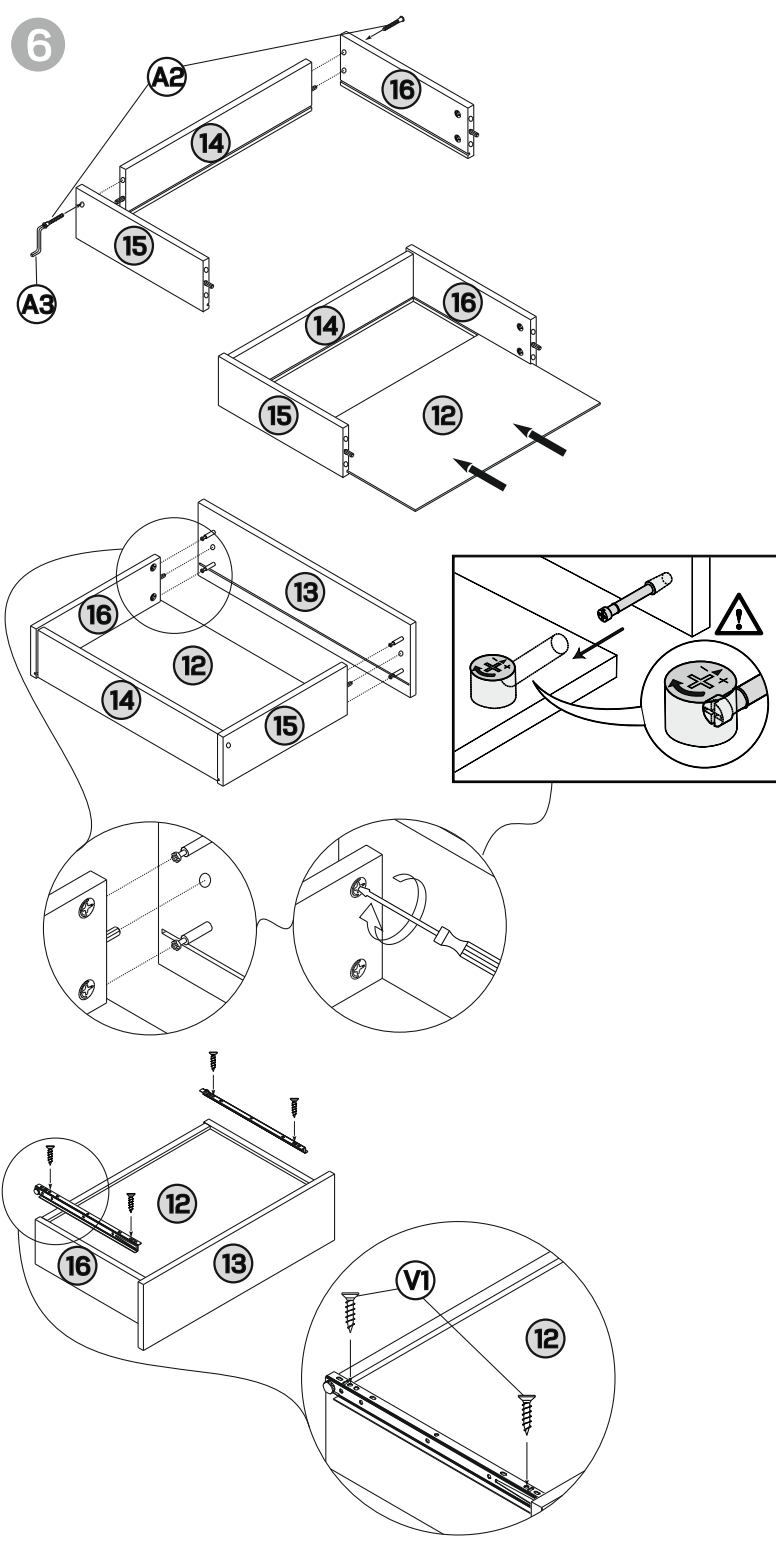

①

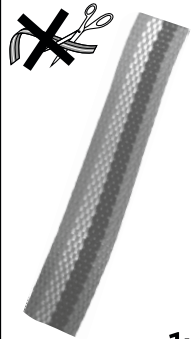

1x

②



3x

③



2x



1.

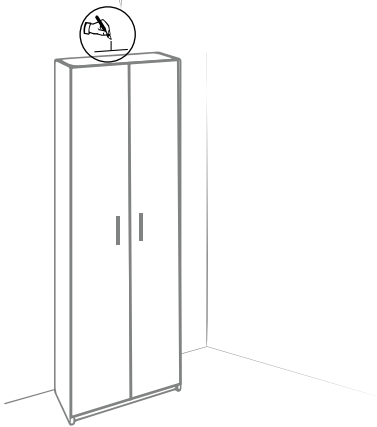
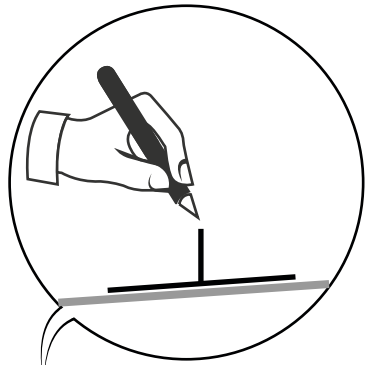

2.

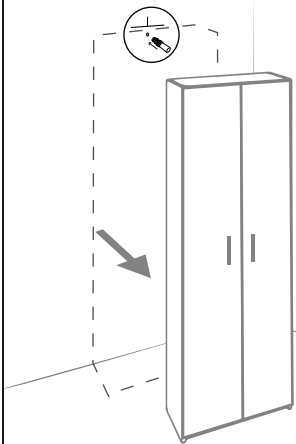
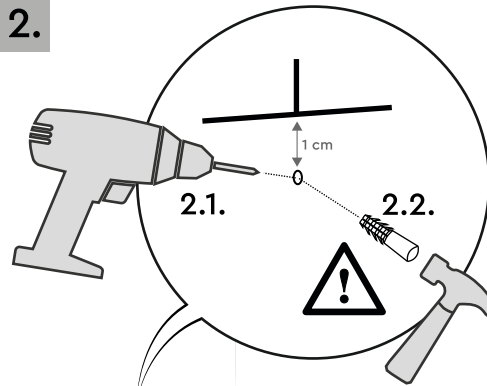

3.

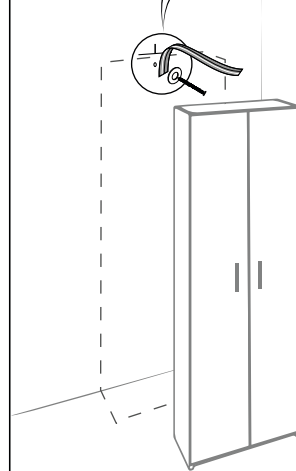
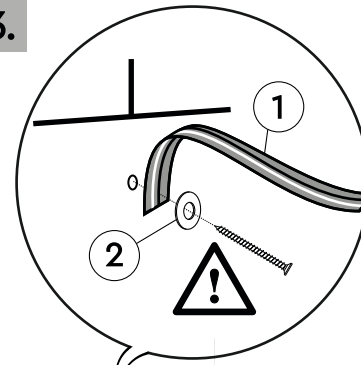

4.

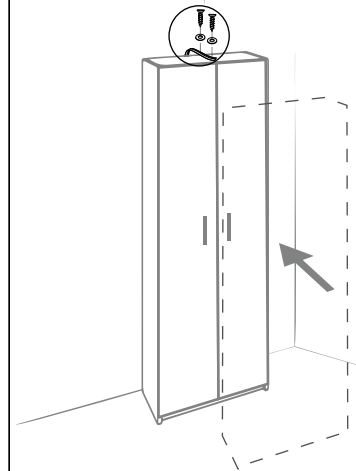
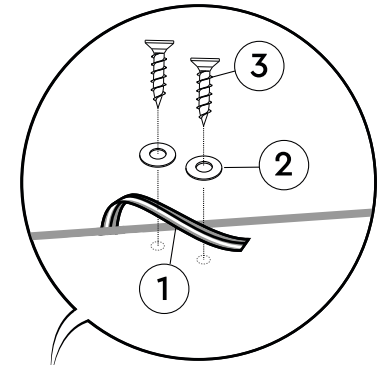
**UYARI**

Güvenliğiniz için ürünü duvara sabitlemeden önce duvar tipini belirleyiniz ve ürünü sabitlemek için buna en uygun dübel ve vidayı temin ediniz. Ardından, montaj şemasında gösterilen adımları izleyerek ürünü duvara sabitleyiniz.

WARNING

For your safety: Check and identify your wall type before fixing the product to the wall. Depending on your wall type, use the most appropriate dowel and screw. Then, fix the product to the wall by following the steps in the product assembly chart.

WARNUNG

Zu Ihrer Sicherheit: Überprüfen und identifizieren Sie Ihren Wandtyp, bevor Sie das Produkt an der Wand befestigen. Verwenden Sie je nach Wandtyp den am besten geeigneten Dübel und die am besten geeignete Schraube. Befestigen Sie dann das Produkt an der Wand, indem Sie die Schritte in der Produktmontagetabelle befolgen.

ATTENTION

Pour votre sécurité: Vérifiez et identifiez votre type de mur avant de fixer le produit au mur. En fonction de votre type de mur, utilisez la cheville et la vis les plus appropriées. Ensuite, fixez le produit au mur en suivant les étapes de la fiche de montage du produit.

ADVERTENCIA

Por su seguridad: Compruebe e identifique su tipo de pared antes de fijar el producto a la pared. Dependiendo de su tipo de pared, utilice la clavija y el tornillo más adecuados. Luego, fije el producto a la pared siguiendo los pasos de la hoja de montaje del producto.

Προειδοποίηση

Για την ασφάλειά σας, πριν τοποθετήσετε το προϊόν στον τοίχο, καθορίστε τον τύπο τοίχου και χρησιμοποιήστε το καταλληλότερο καρφί και βίδα για να στερεώσετε το προϊόν. Στη συνέχεια, τοποθετήστε το προϊόν στον τοίχο ακολουθώντας τα βήματα στο διάγραμμα συναρμολόγησης.

ATENȚIE

Pentru siguranța dvs. : Verificați și identificați tipul de perete înainte de a fixa produsul pe perete. În funcție de tipul de perete, utilizați cel mai potrivit diblu și șurub. Apoi, fixați produsul pe perete urmând pașii din tabelul de asamblare al produsului.

ATTENZIONE

Per sicurezza, verificate il tipo di parete prima di fissare il prodotto alla parete stessa. Secondo il tipo di parete, utilizzate il tipo di tassello e di vite più idonei e fissate il prodotto alla parete, secondo le istruzioni di montaggio allegate.

من أجل سلامتك: تحقق من نوع الحائط وحدده قبل تثبيت المنتج على الحائط. اعتمادًا على نوع الحائط الخاص بك، استخدم المسامير واللولب الأنسب. ثم ثبت المنتج على الحائط باتباع الخطوات الواردة في مخطط تجميع المنتج

تحذير