

# ALSAPAN

ZI du Petit Breuil  
23100 LA COURTINE

**NOTICE DE MONTAGE**  
**ASSEMBLING INSTRUCTIONS**  
**MONTAGEANLEITUNG**  
**ISTRUZIONI DI MONTAGGIO**  
**INSTRUCCOES DE MONTAGEM**  
**INSTRUCCIONES DE MONTAJE**  
**UPUTE ZA MONTAZU**  
**MONTAJ TALIMATI**

## Caisson 1 tiroir + penderie

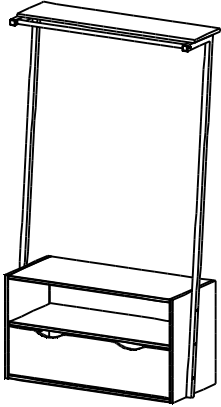

1:00

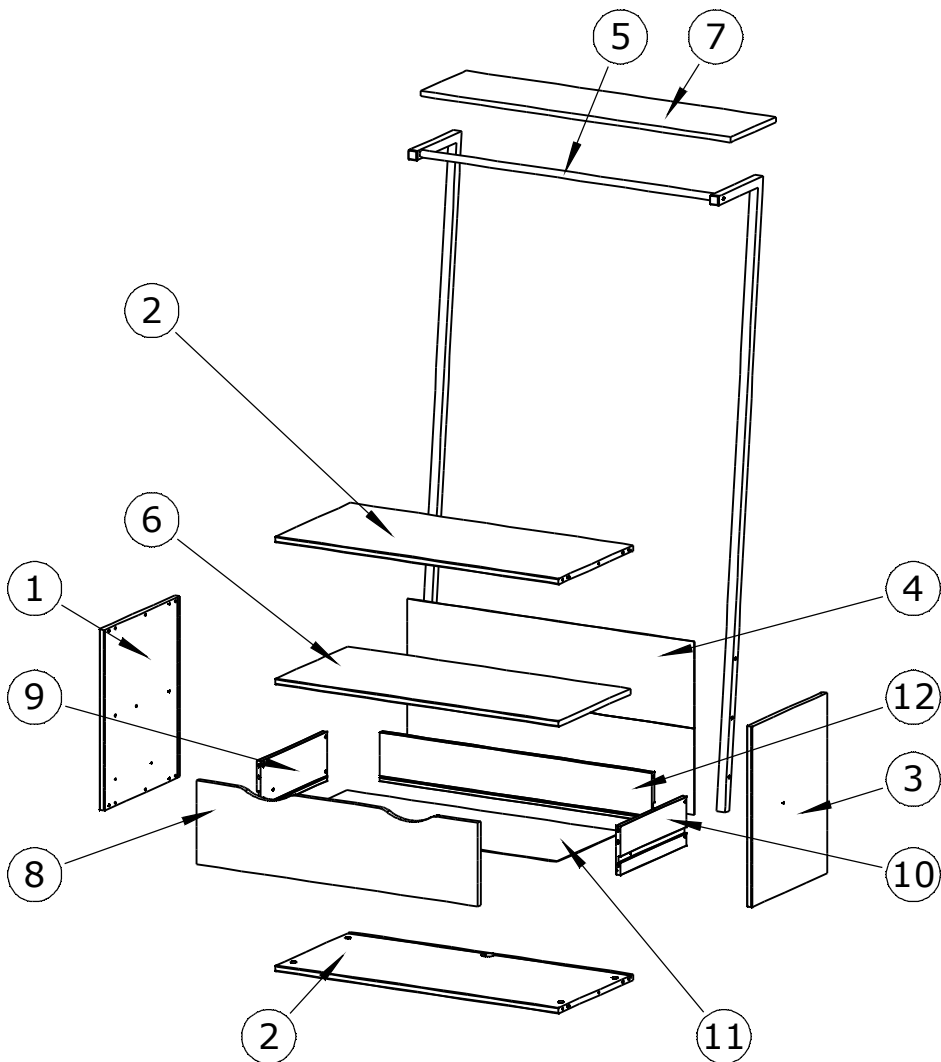
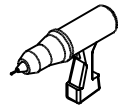
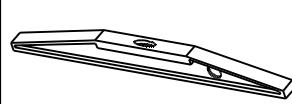
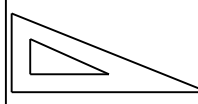
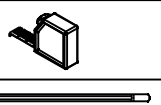
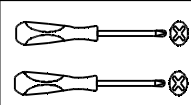
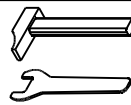

N°	Dimensions
1	497x400x15 mm
2	868x398x15 mm
3	497x400x15 mm
4	881x477x3 mm
5	1714x240x25 mm
6	868x384x15 mm
7	950x240x15 mm
8	864x230x15 mm
9	351x135x12 mm
10	351x135x12 mm
11	847x350x3 mm
12	835x135x12 mm



<b>A</b>		<b>8x</b> (504029)
<b>B</b>		<b>12x</b> ø5x30 mm (12928)
<b>C</b>		<b>4x</b> M6x25 mm (433584)
<b>D</b>		<b>4x</b> ø4x15 mm (452468)
<b>E</b>		<b>2x</b> ø8x30 mm (12920)
<b>F</b>		<b>2x</b> M4x35 mm (38648)
<b>G</b>		<b>2x</b> M4x15 mm (38655)
<b>H</b>		<b>4x</b> ø4x35 mm (38621)
<b>I</b>		<b>7x</b> ø3,5x15 mm (31602)
<b>J</b>		<b>2x</b> M4x9 mm (38646)
<b>K</b>		<b>4x</b> (2001195)
<b>L</b>		<b>4x</b> ø6,6x40 mm (482719)
<b>T</b>		52140 <b>1x 2 pièces</b>
		<b>M</b> 500617 <b>8x</b>
		<b>N</b> 22391 <b>4x</b>
		<b>O</b> 452549 <b>2x</b>
		<b>P</b> 2063331 <b>4x</b>
		<b>Q</b> 430654 <b>1x</b>
		<b>R</b> 52259 <b>16x</b>
		<b>S</b> 28403 <b>2x</b>

# 1

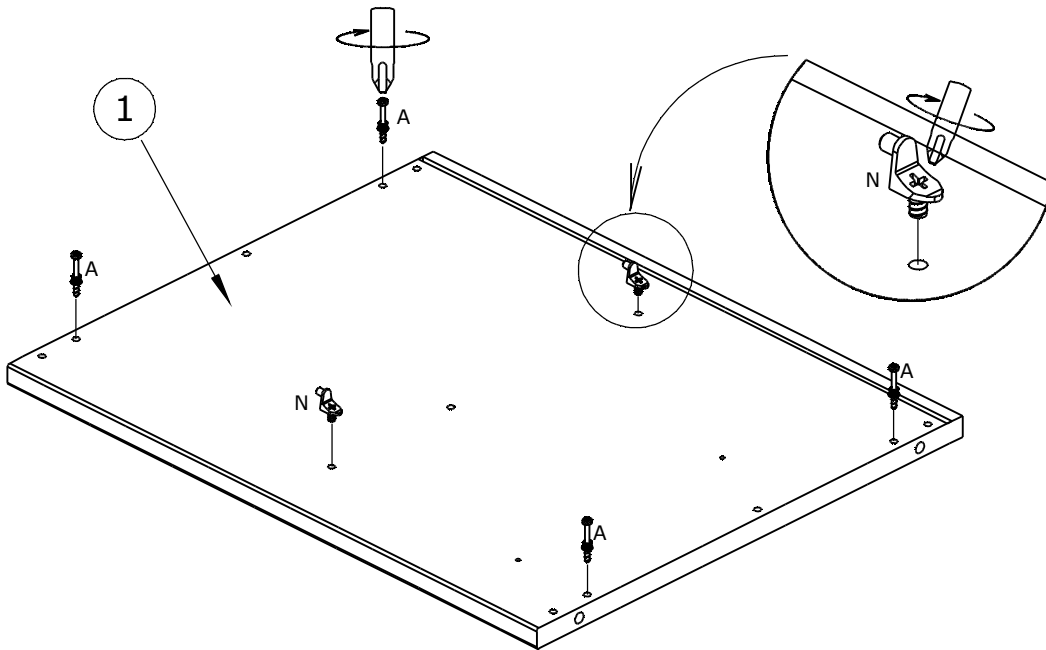
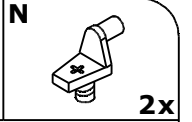
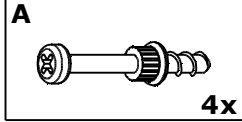
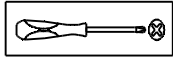

# 2

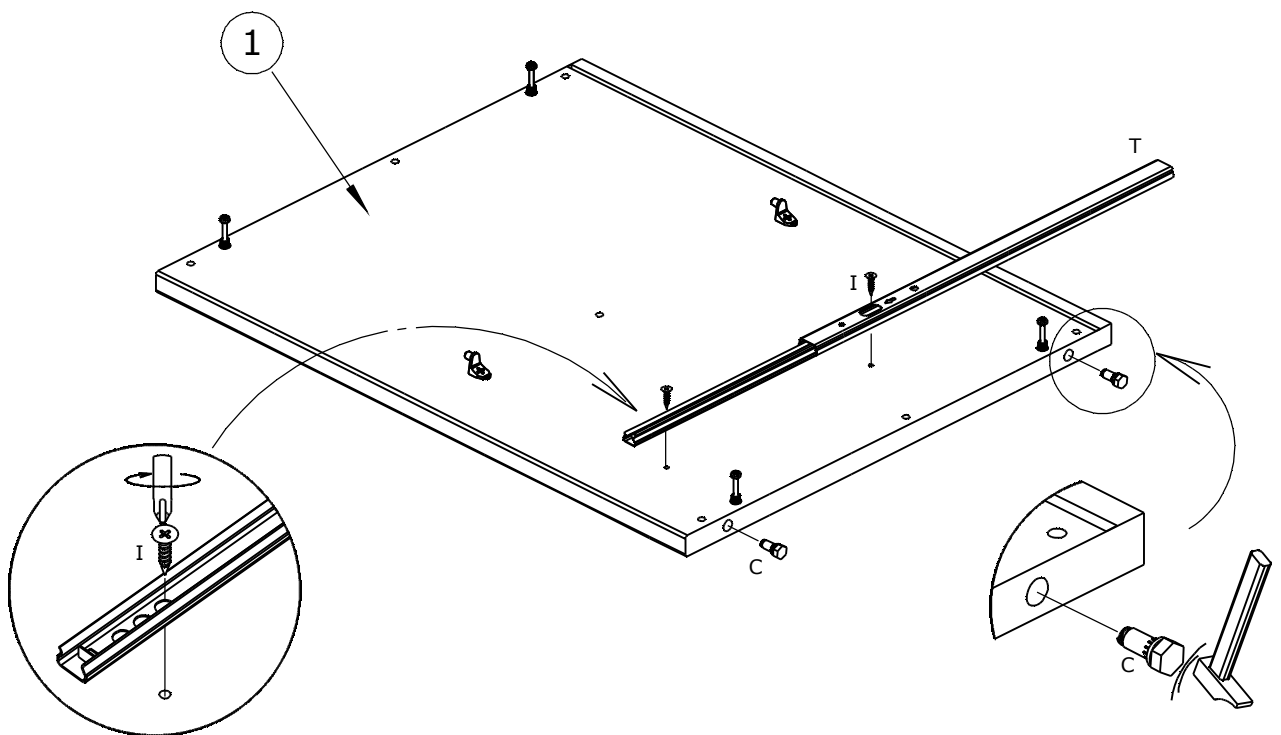
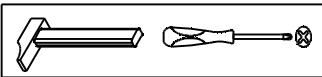
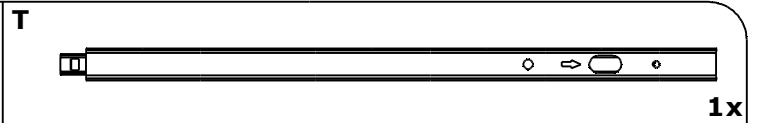
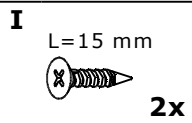
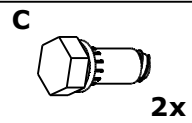

# 3

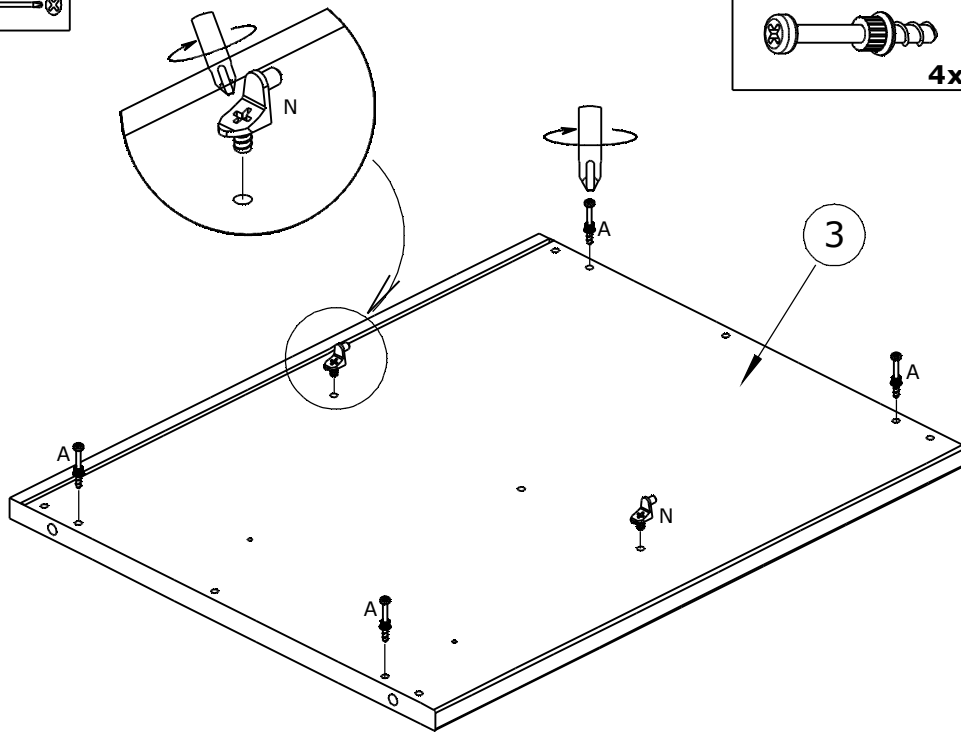
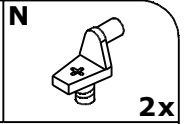
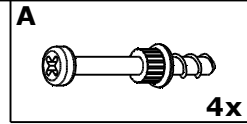
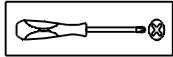

# 4

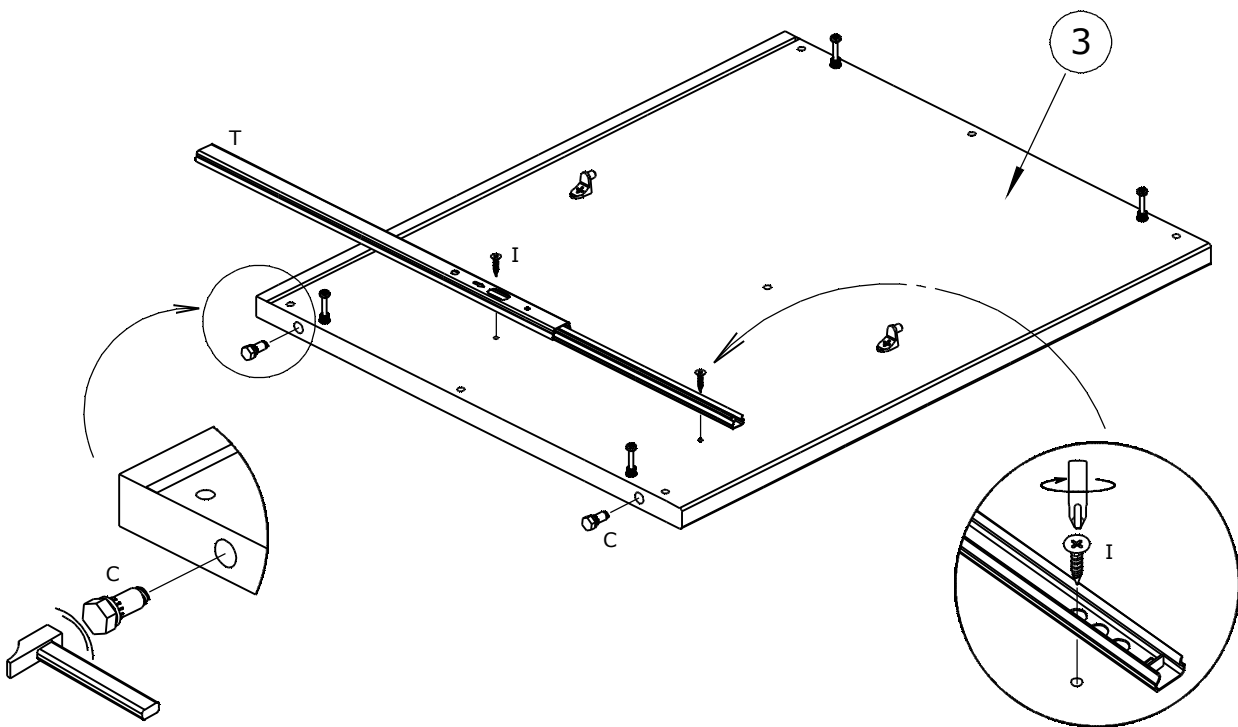
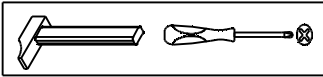
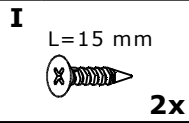
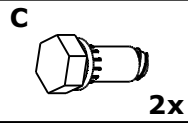

**5**

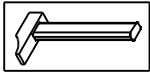

**B**  $\varnothing 5 \times 30$  mm  
12x

**M**  
8x

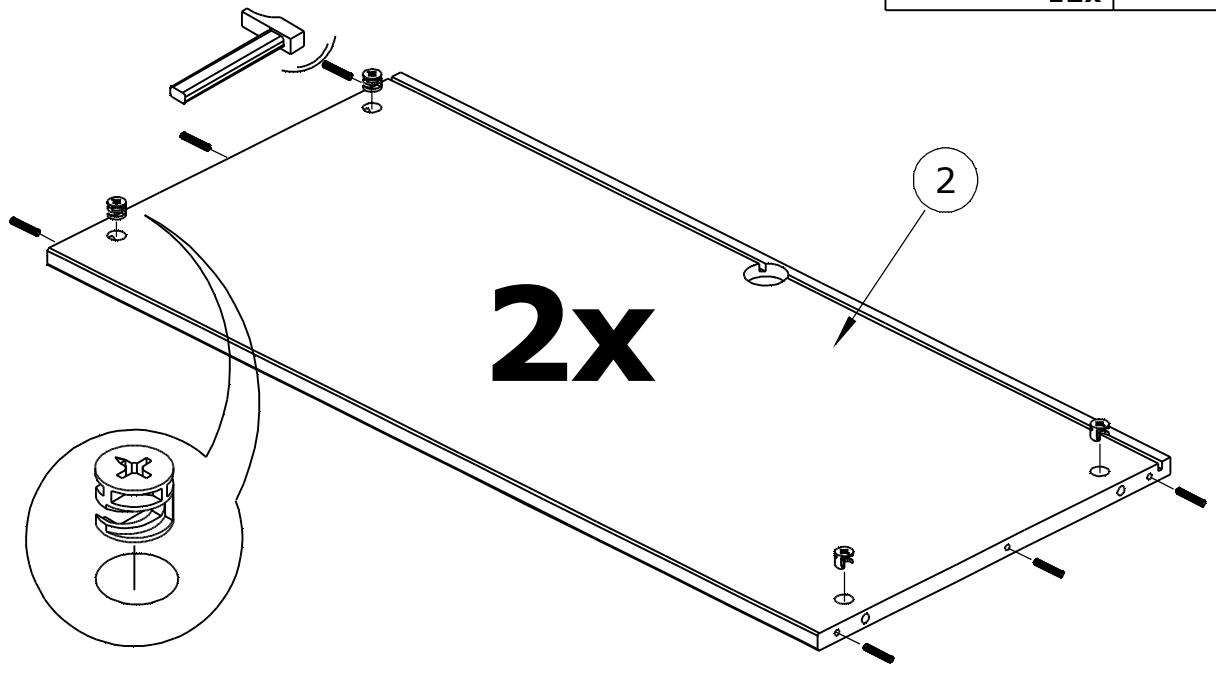

**6**

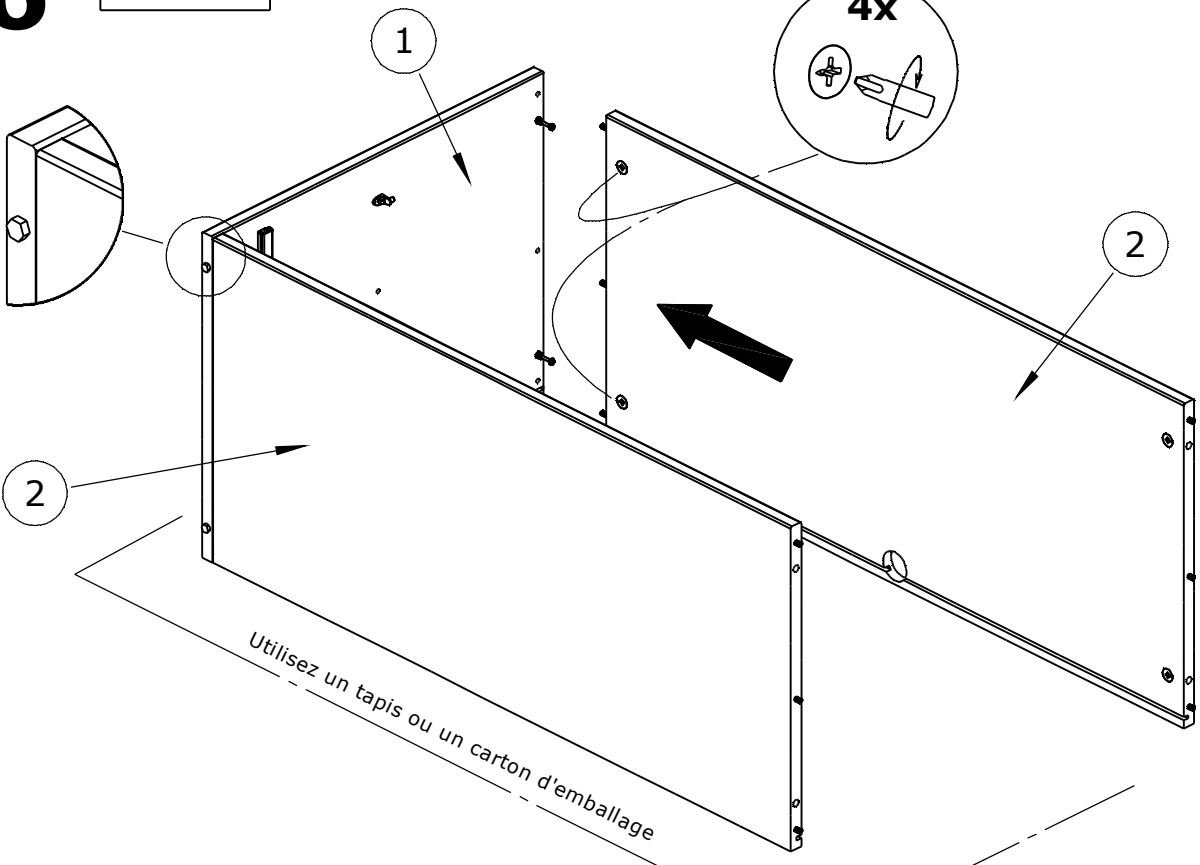
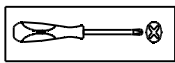

Utilisez un tapis ou un carton d'emballage

# 7

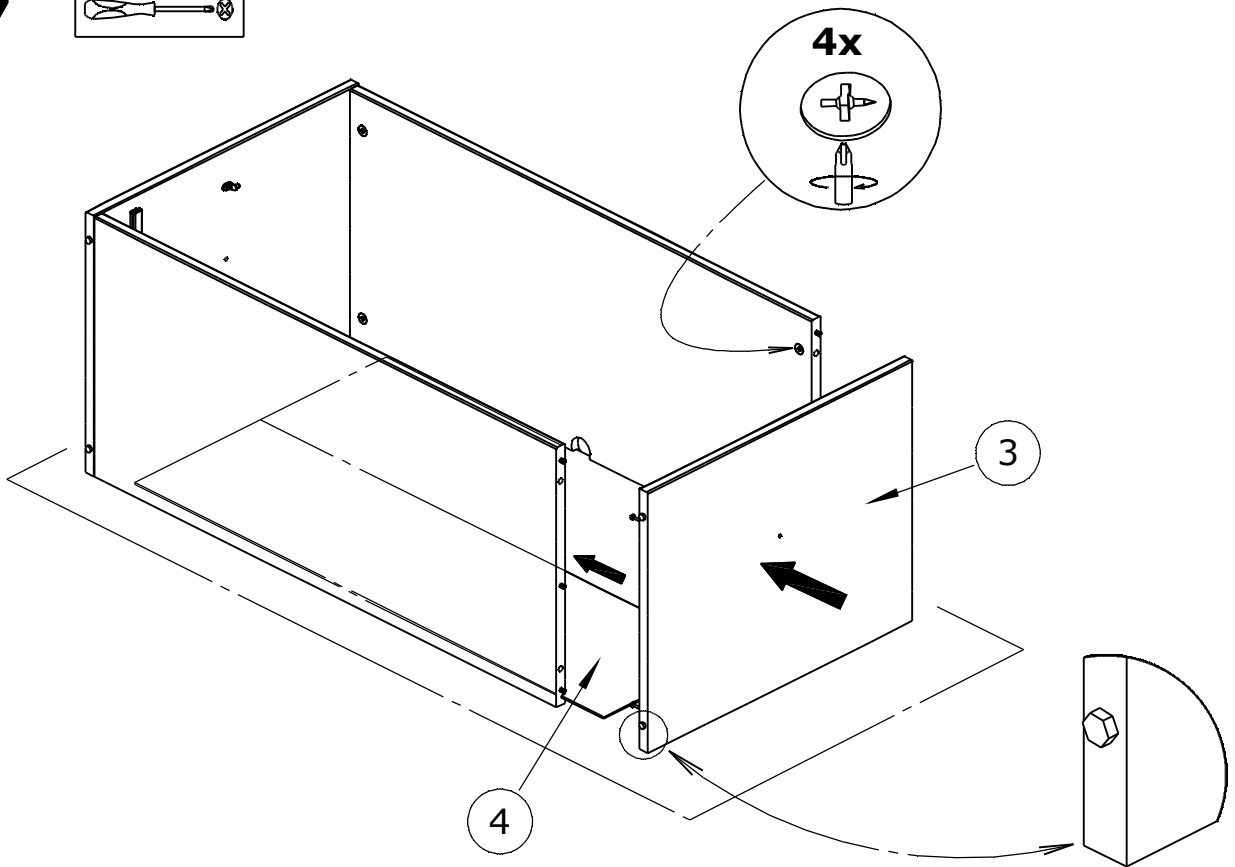
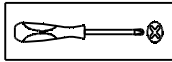

# 8

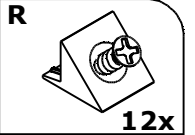
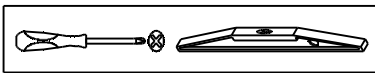

90°

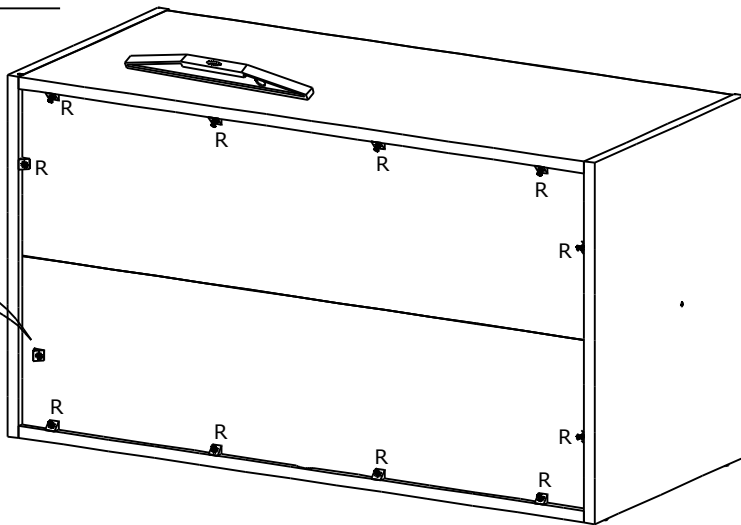

**1 Insérer** dans la rainure  
**2 Fixer**

# 9a

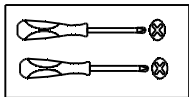

Quincaillerie 5a et 5b  
livrée avec penderie.

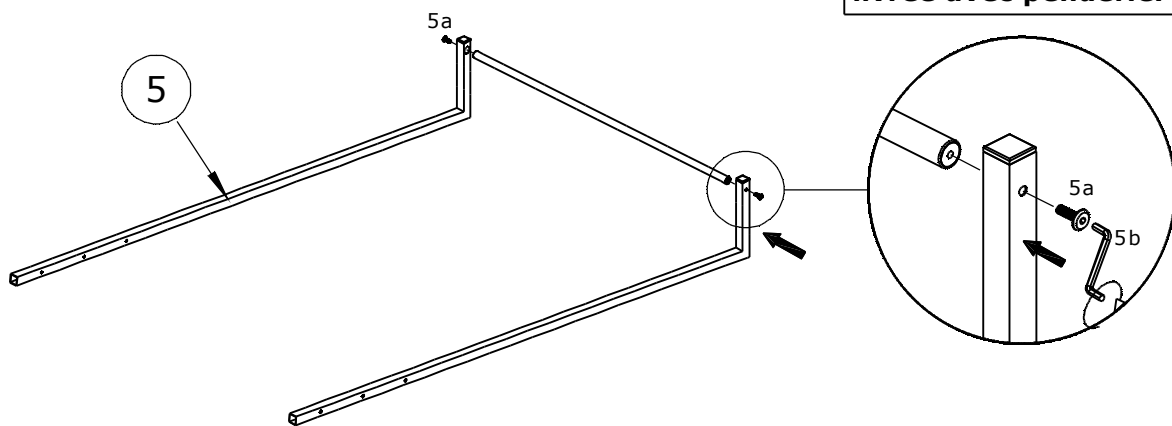

# 9b

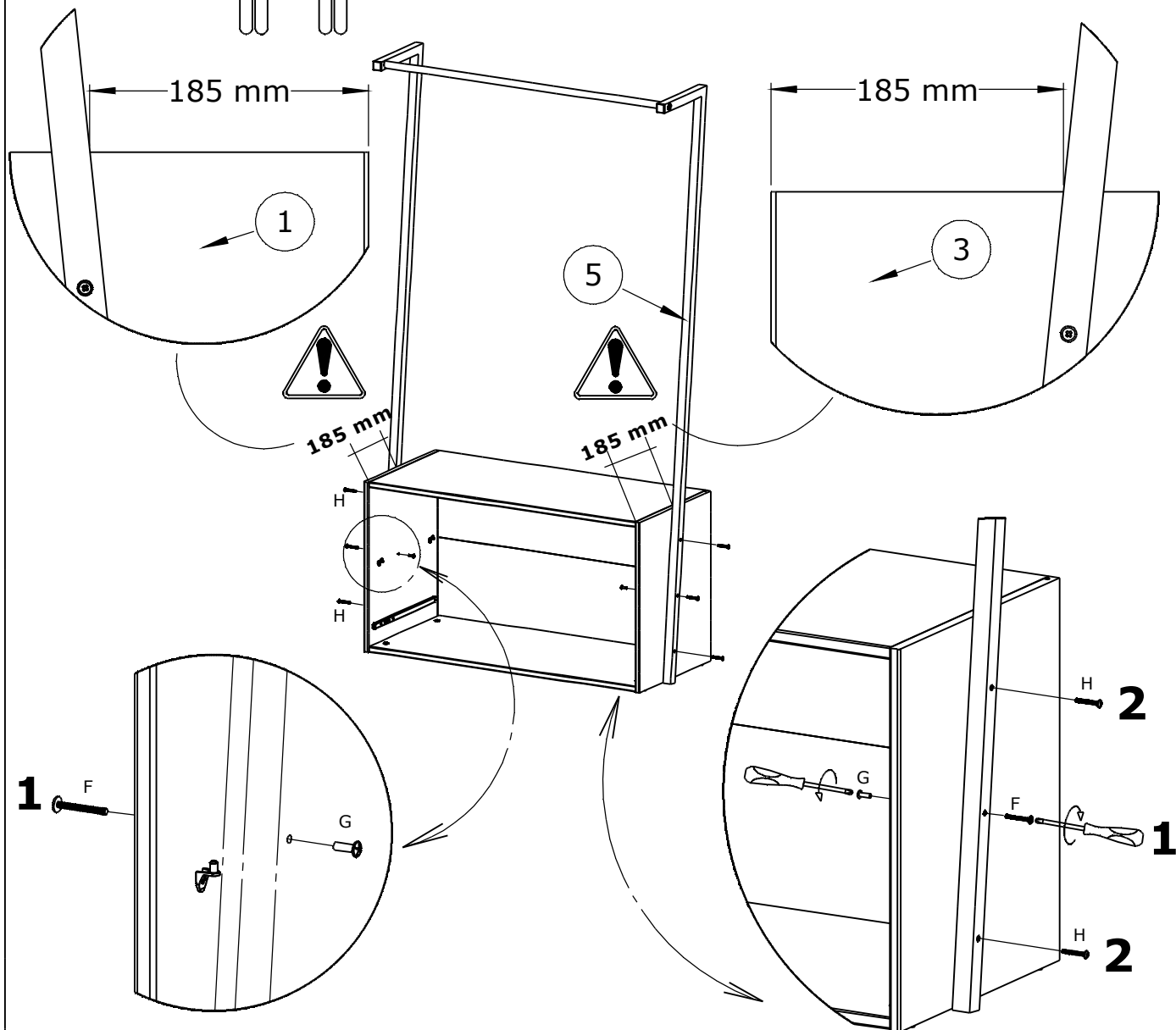
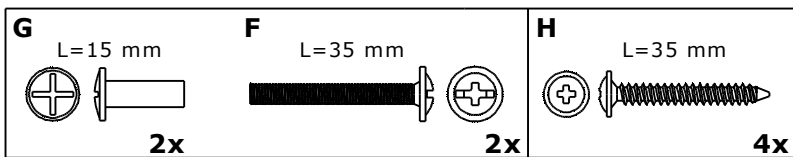
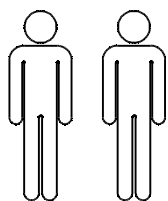

# 10

**I** L=15 mm  
  
**3x**

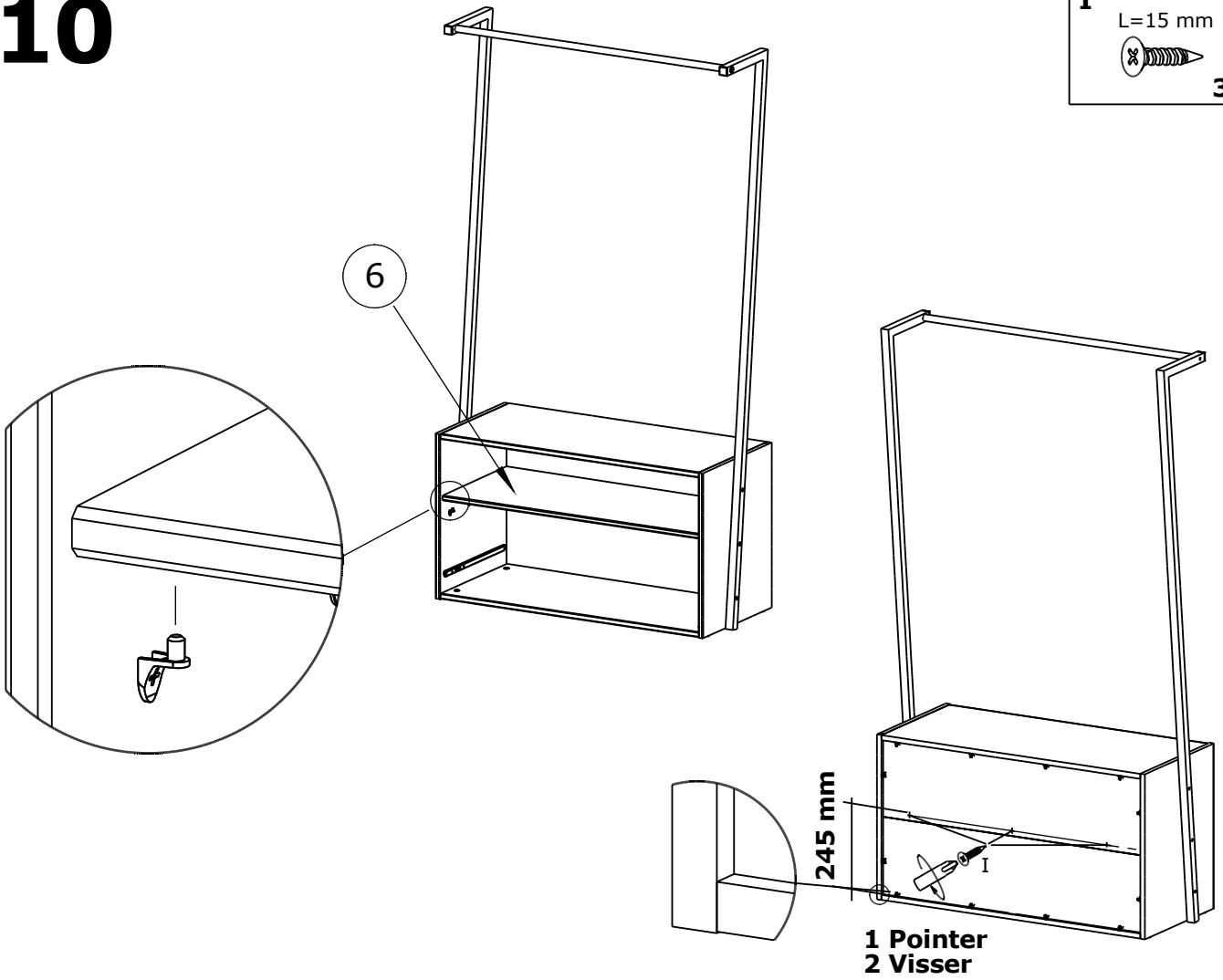

# 11

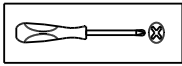

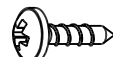
**D** L=15 mm  
  
**4x**

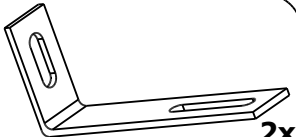
**O**  
  
**2x**

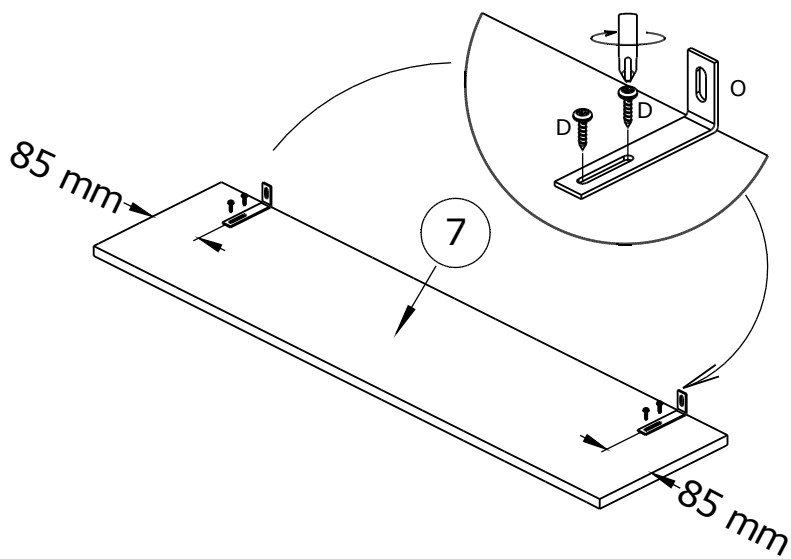



# 12

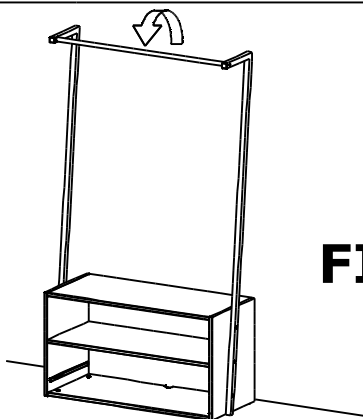
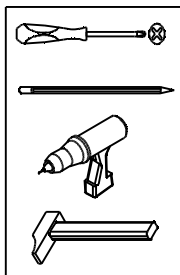

Q Sangle anti-basculement

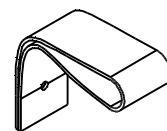

1x

## FIXATION MURALE

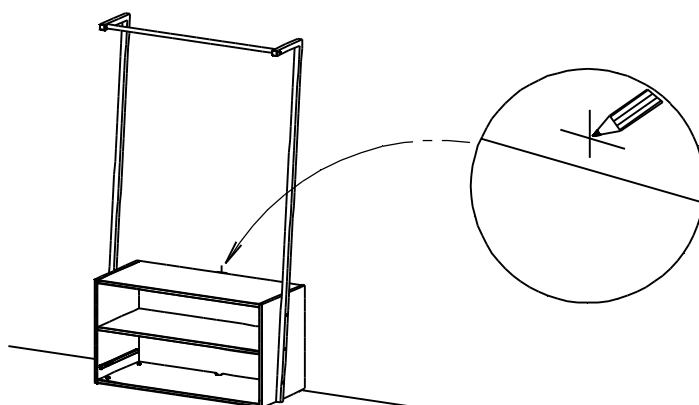

**1 TRACER**

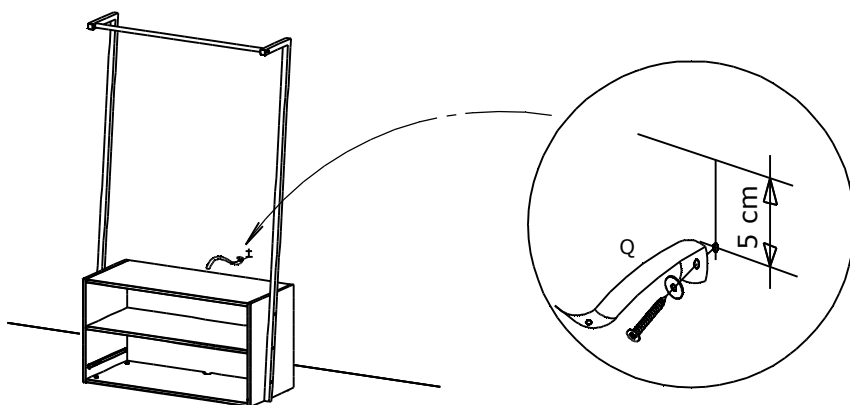

**2 FIXER AU MUR**  
5 cm en dessous du traçage

**ATTENTION !**  
Cheville et vis de fixation murale **NON FOURNIES.**

*Vous devez les choisir en fonction du matériau de votre mur.*

*Si besoin adressez-vous à un magasin spécialisé.*

# 13

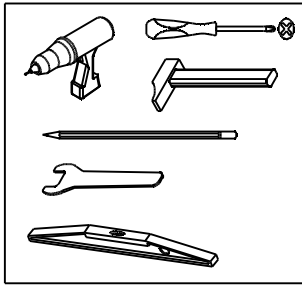

## FIXATION MURALE

- 1 Traçage de la position du perçage de fixation sur votre mur
- 2 Montage cheville et vis de fixation murale

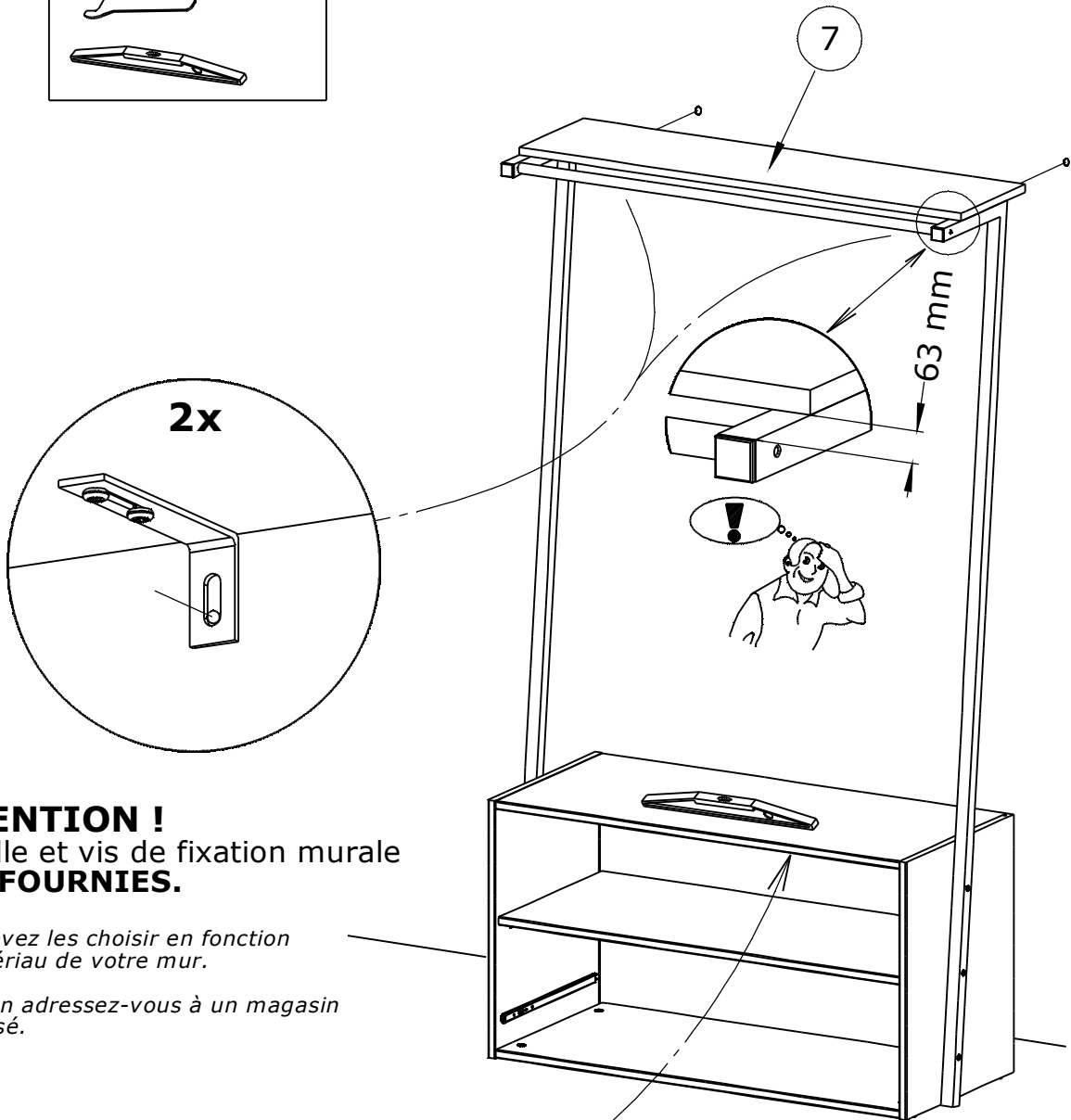

**ATTENTION !**  
Cheville et vis de fixation murale  
**NON FOURNIES.**

*Vous devez les choisir en fonction  
du matériau de votre mur.*

*Si besoin adressez-vous à un magasin  
spécialisé.*

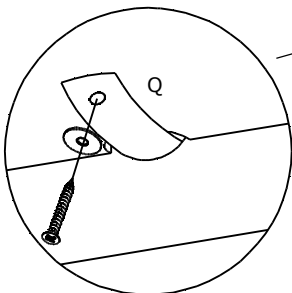

**Fixer la sangle au meuble**

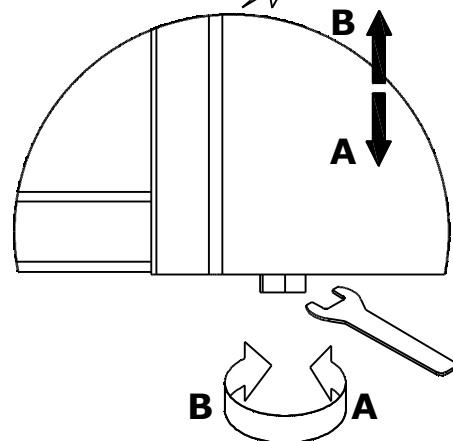

# 14

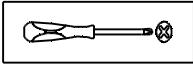
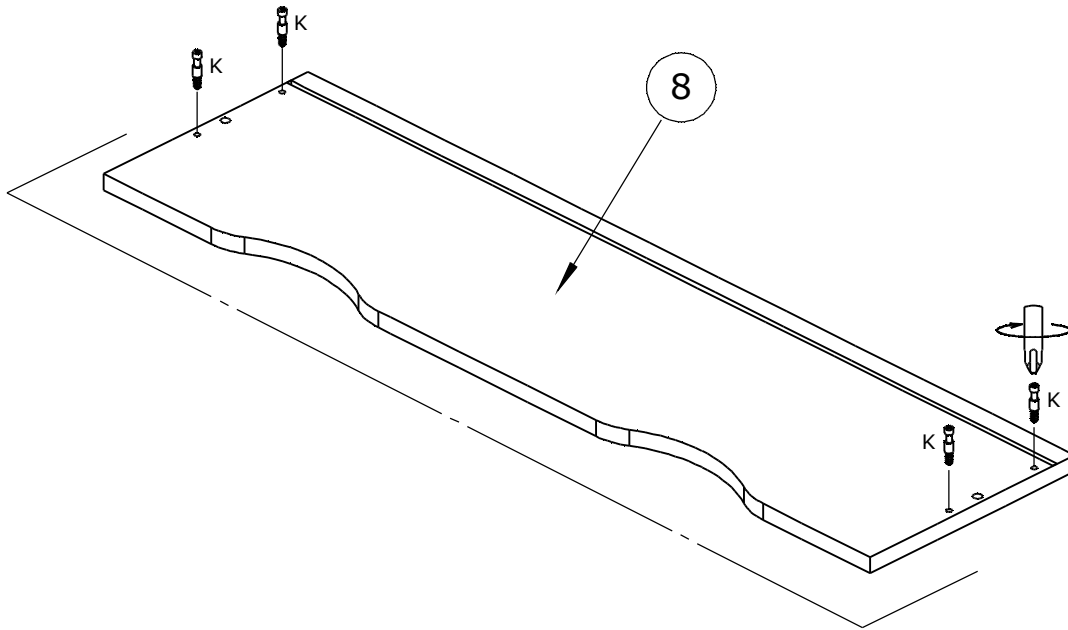
**K****4x**

# 15

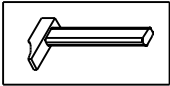
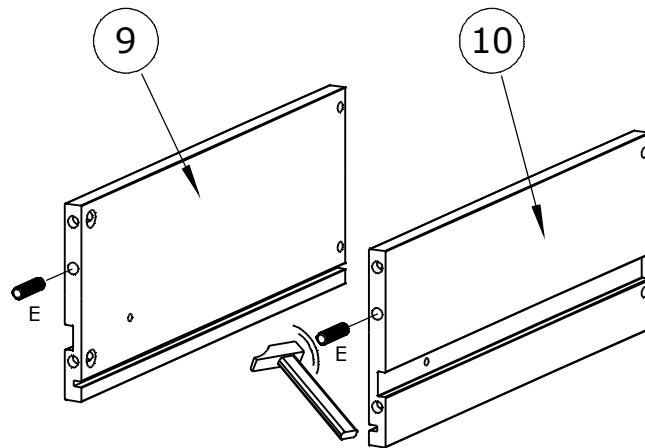
**E****ø8x30 mm****2x**

# 16

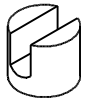
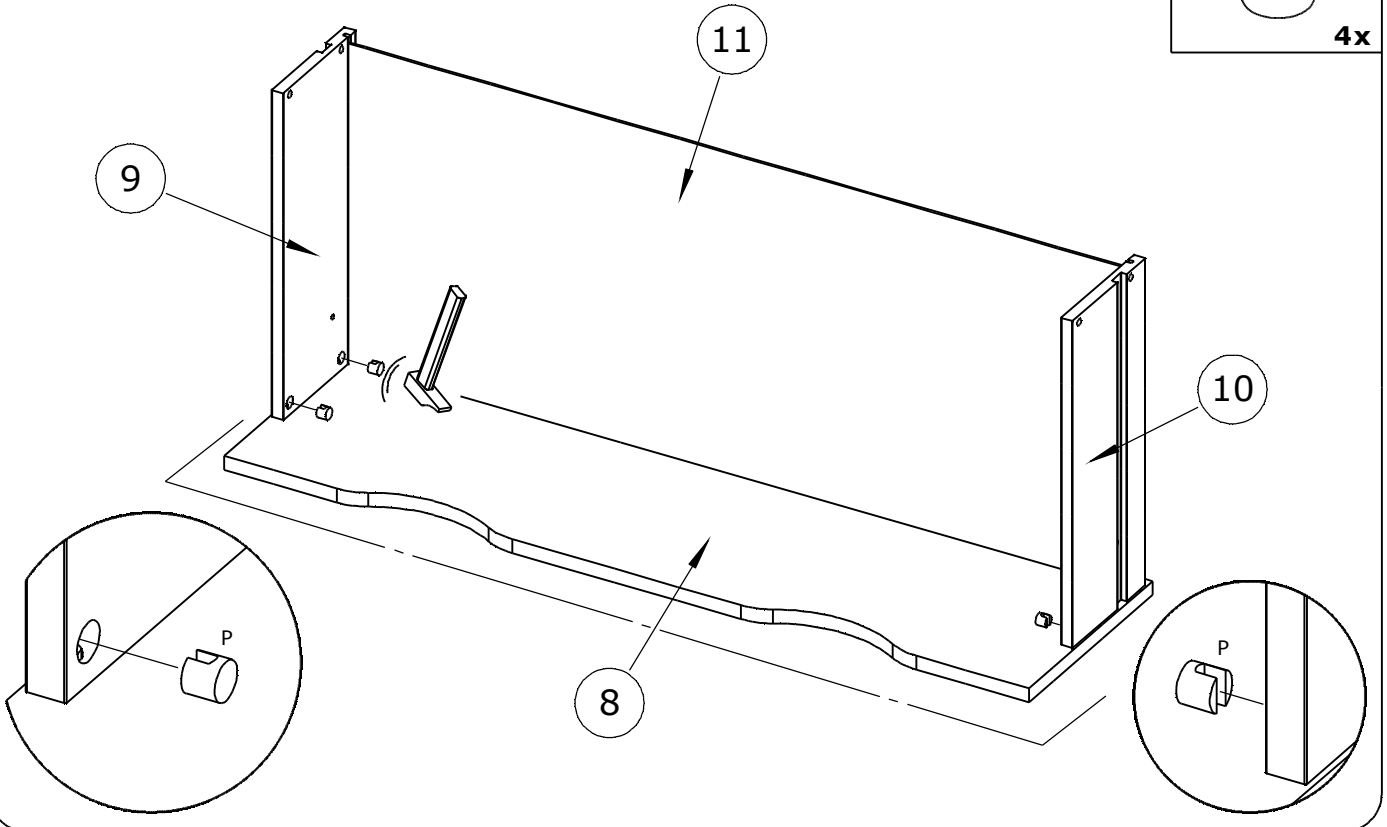
**P****4x**

# 17

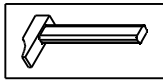
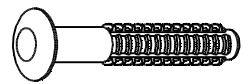
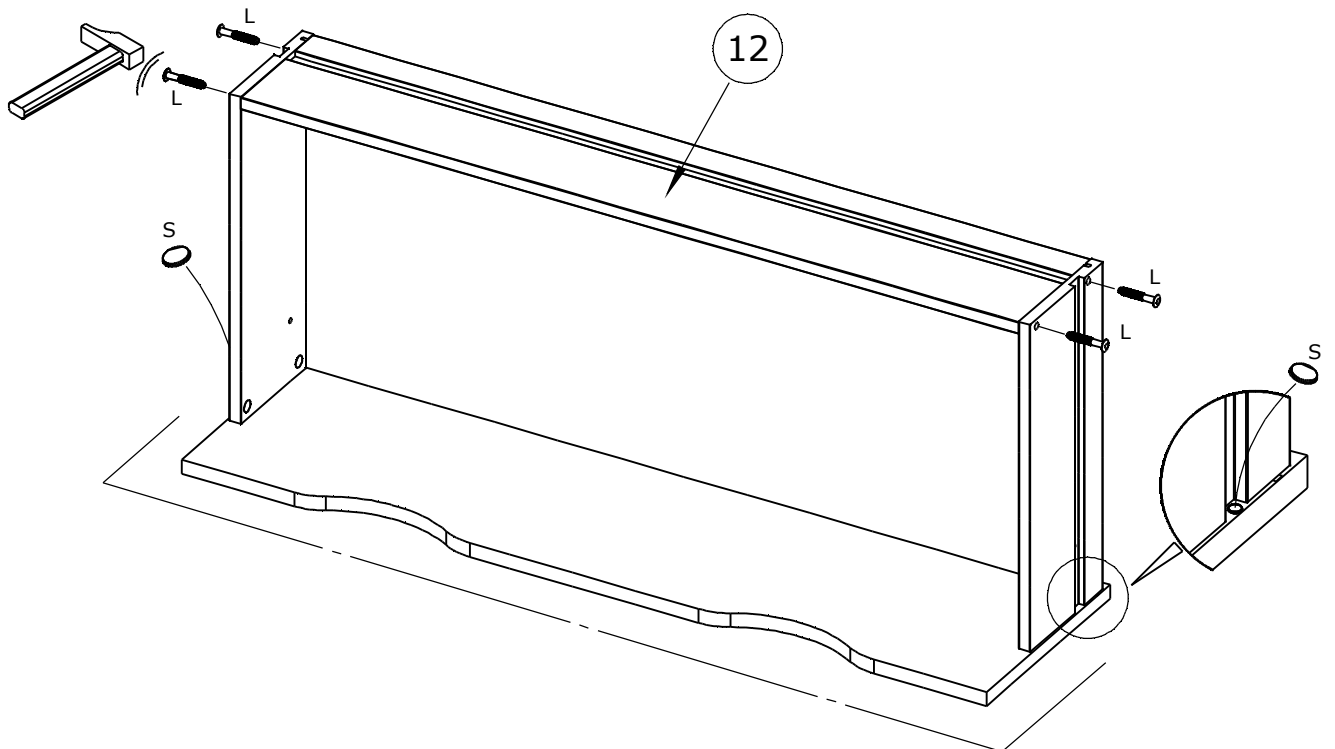
**S****2x****L****4x**

# 18

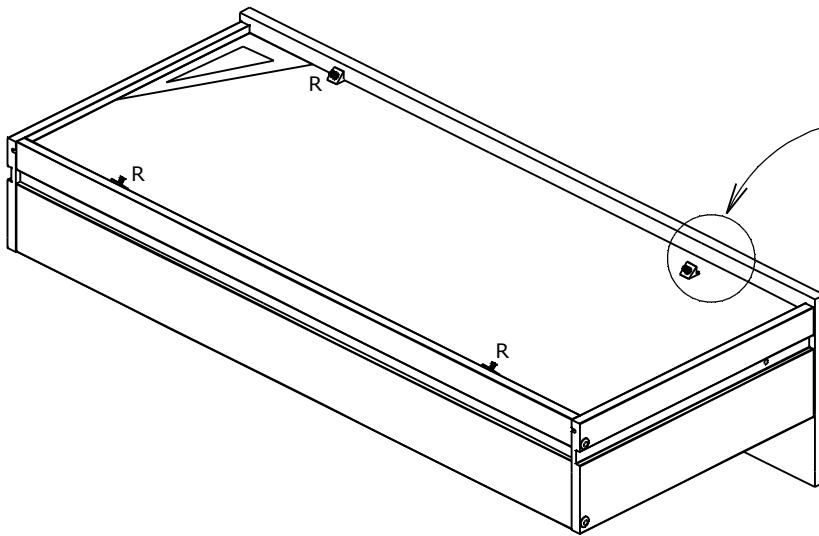
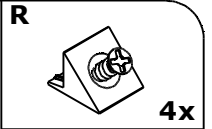
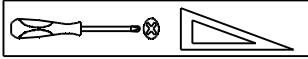

**1** Insérer dans la rainure  
**2** Fixer

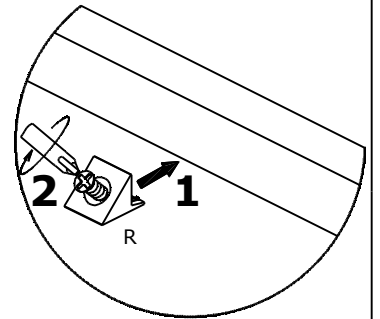

# 19

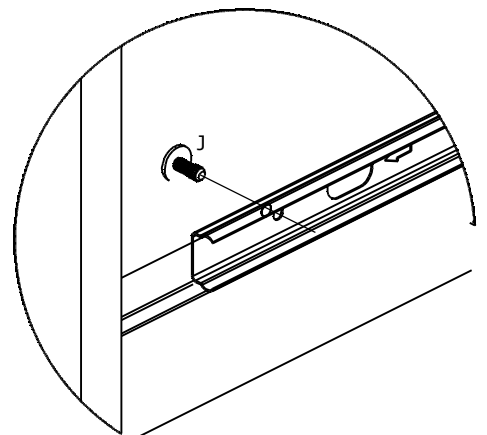
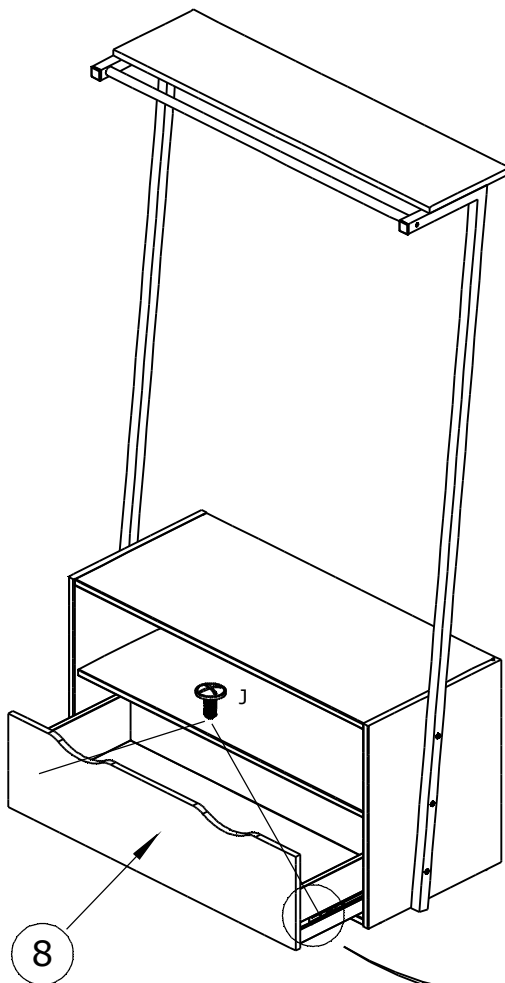
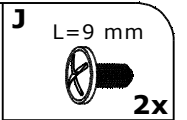
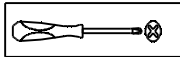

**F CONSEILS D'ENTRETIEN :**

- 1) Dépoussiérez soigneusement.
- 2) Humectez un chiffon doux et propre, d'eau légèrement savonneuse.  
Ne jamais utiliser de produits abrasifs : poudre, laine d'acier, solvants.  
Ne pas mouiller copieusement.



**NE JAMAIS FORCER LES ASSEMBLAGES  
RESSERRER LES VIS APRES QUELQUES TEMPS D'USAGE  
GARDER VOTRE NOTICE DE MONTAGE, SI UNE PIECE  
VENAIT A MANQUER, ELLE SERAIT LE PLUS CLAIR MOYEN  
DE COMMUNIQUER AVEC VOTRE MAGASIN.**

**GB NOTICE FOR MAINTENANCE :**

- 1) Dust of carefully.
- 2) Use a soft, proper and humid duster and light soap solution to clean the furniture.  
Please do not use any scouring agent like powder, steel wool, solvents.  
Do not wet too much.



**NEVER FORCE THE CONNECTIONS  
RE-TIGHTEN THE SCREWS AFTER FEW DAYS.  
PLEASE RETAIN THE AI LEAFLET FOR FUTURE REFERENCE,  
THE AI CONTAINS INFORMATION WHEN CLAIMING  
FOR MISSING PARTS.**

**D PFLEGEHINWEISE :**

- 1) Sorgfältig entstauben.
- 2) Mit einem weichen, sauberen und feuchten Tuch und leichter Seifenlauge reinigen.  
Benutzen Sie keine Scheuermittel wie Pulver, Stahlwolle, Lösungsmittel.  
Nicht zu nass abwischen.



**NIEMALS DIE VERBINDUNGEN ZU STARCK ANZIEHEN  
DIE SCHRAUBEN NACH EINIGER ZEIT DES GEBRAUCHS  
ERNEUT FESTZIEHEN. DIE MONTAGEANLEITUNG GUT  
AUFBEWAHREN, SOLLTE EIN TEIL FEHLEN , IST SIE DAS  
BESTE VERSTÄNDIGUNGSMITTEL MIT IHREM GESCHÄFT.**

**I CONSIGLI PER LA MANUTENZIONE :**

- 1) Spolverate accuratamente.
- 2) Inumidire con acqua leggermente insaponata uno straccio morbido e pulito.  
Non utilizzare mai prodotti abrasivi : polvere, lana di acciaio, solventi.  
Non bagnare troppo.



**NON FORZARE MAI GLI ASSEMBLAGGI  
RISTRINGERE LE VITI DOPO UN PERIODO D'USO  
CONSERVARE QUESTE ISTRUZIONI DI MONTAGGIO, SE  
UN PEZZO VENISSE A MANCARE SAREBBE IL MIGLIORE  
MEZZO DI COMUNICAZIONE CON IL RIVENDITORE.**

**E RECOMENDACIONES PARA EL MANTENIMIENTO :**

- 1) Despolvorear cuidadosamente.
- 2) Humedecer un pano suave y limpio con agua ligeramente enjabonada.  
No use nunca productos abrasivos tales como : polvo de limpiar, lana de acero, solventes.  
No mojar exageradamente.



**NO FUERCE NUNCA EN LAS UNIONES . APRIETE LOS  
TORNILLOS DESPUES DE CIERTO TIEMPO DE UTILIZACION  
CONSERVE SU MANUAL DE MONTAJE, SI FALTARA UNA  
PIEZA, SERIA LA MANERA MAS FACIL DE COMUNICAR  
CON LA TIENDA.**

**P NORMAS DE MANUTENCAO :**

- 1) Eliminar bem o po.
- 2) Umedecer um pano suave e limpo com agua e um pouco de sabao.  
Nunca utilizar produtos abrasivos : pos, la de aço, solventes.  
Nao molhar demasiado.



**NUNCA FORCAR OS ENCAIXES.REAPERTAR OS  
PARAFUSOS APOS UM TEMPO DE UTILIZACAO.  
GUARDAR AS INSTRUCOES DE MONTAGEM.  
CASO FALTE ALGUMA PECA , O MAIS A CONSELHABEL  
E CONTATAR O REVENDEDOR.**

**TR BAKIM TALIMATLARI :**

- 1) Tozunu dikkatlice aliniz.
- 2) Yumusak bir bezi temiz su ve az miktarda sabunla (deterjan) nemlendiriniz  
- Asla asındirici ürünler kullanmayiniz : Celik yünü, solvent  
- Bol suyla yikamayiniz.



**MONTAJLARI ZORLAMAYINIZ.  
BIRKAC KULLANIMDAN SONRA VIDALARI SIKISTIRINIZ.  
BIR PARCANIN KAYBOLMASI DURUMUNDA MAGAZANIZ-  
LADAH KOLAY ILETISIME GECEBILMENIZ ICIN MONTAJ  
KULLANIM TALIMATINIZI SAKLAYINIZ.**

**HR UPUTE ZA ODRZAVANJE :**

- 1) Pazljivo obrisati prasinu.
- 2) Koristite suhu krpu.  
- Zabranjena je upotreba kemikalija ili bilo kakvih pomocnih sredstava za ribanje jakih sredstava za ciscenje ili celigne vune  
- Ne mokra.



**NEMOJTE UPOTREBLJAVATI SILU PRILIKOM SKLAPANJA  
NAKON NEKOG VREMENA PONOVRNO PRITEGNITE VIJKE  
CUVAJTE UPUTE ZA MONTAZU  
U SLUCAJU NEDOSTATKA NEKOG DIJELA NAJBOJE CE BITI  
DA KONTAKIRATE PRODAJNO MJESTO.**