

**NOTICE DE MONTAGE  
ASSEMBLING INSTRUCTIONS  
MONTAGEANLEITUNG  
ISTRUZIONI DI MONTAGGIO  
INSTRUCOES DE MONTAGEM  
INSTRUCCIONES DE MONTAJE  
UPUTE ZA MONTAZU  
MONTAJ TALIMATI  
MONTAGE-INSTRUCTIES**

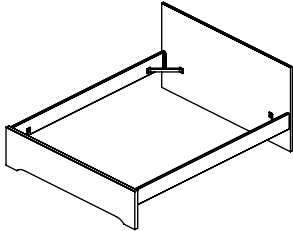

**Lits 140x190 - Bedden van 140x190 - Betten 140x190**

<b>Réf. 561775</b> <b>Réf. 523766</b> décor imitation chêne clair Licht eiken Nachbildung Eiche hell	<b>Réf. 561776</b> <b>Réf. 523767</b> décor imitation chêne argile Grijsst eiken Nachbildung Eiche lehm	<b>Réf. 561777</b> <b>Réf. 523768</b> décor imitation chêne nature Natural eiken Nachbildung Eiche natur	<b>Réf. 561778</b> <b>Réf. 523769</b> décor imitation noyer brun Bruin notenhout Nachbildung Nussbaum dunkel	<b>Réf. 545038</b> décor blanc brillant kleur glanzend wit Weiss glänzend
--	---	--	---	--

**Lits 140x200 - Bedden van 140x200 - Betten 140x200**

<b>Réf. 545081</b> décor imitation chêne clair Licht eiken Nachbildung Eiche hell	<b>Réf. 545082</b> décor imitation chêne argile Grijsst eiken Nachbildung Eiche lehm	<b>Réf. 545083</b> décor imitation chêne nature Natural eiken Nachbildung Eiche natur	<b>Réf. 545084</b> décor imitation noyer brun Bruin notenhout Nachbildung Nussbaum dunkel	<b>Réf. 545085</b> décor blanc brillant kleur glanzend wit Weiss glänzend
--	---	--	---	--

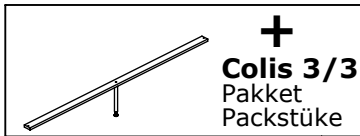

**Lits 160x200 - Bedden van 160x200 - Betten 160x200**

<b>Réf. 561779</b> <b>Réf. 523770</b> décor imitation chêne clair Licht eiken Nachbildung Eiche hell	<b>Réf. 561780</b> <b>Réf. 523771</b> décor imitation chêne argile Grijsst eiken Nachbildung Eiche lehm	<b>Réf. 561781</b> <b>Réf. 523772</b> décor imitation chêne nature Natural eiken Nachbildung Eiche natur	<b>Réf. 561782</b> <b>Réf. 523773</b> décor imitation noyer brun Bruin notenhout Nachbildung Nussbaum dunkel	<b>Réf. 545039</b> décor blanc brillant kleur glanzend wit Weiss glänzend
--	---	--	---	--

**Réf. 547342 Réf. 547343 Réf. 547344 Réf. 547345**

décor imitation chêne clair Licht eiken Nachbildung Eiche hell	décor imitation chêne argile Grijsst eiken Nachbildung Eiche lehm	décor imitation chêne nature Natural eiken Nachbildung Eiche natur	décor imitation noyer brun Bruin notenhout Nachbildung Nussbaum dunkel	décor blanc brillant kleur glanzend wit Weiss glänzend
--	---	--	---	--

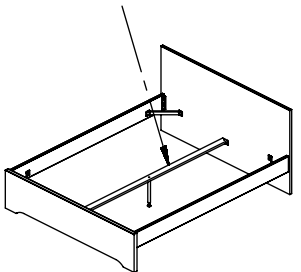

**Lits 180x200 - Bedden van 180x200 - Betten 180x200**

<b>Réf. 561783</b> <b>Réf. 523775</b> décor imitation chêne clair Licht eiken Nachbildung Eiche hell	<b>Réf. 561784</b> <b>Réf. 523776</b> décor imitation chêne argile Grijsst eiken Nachbildung Eiche lehm	<b>Réf. 561785</b> <b>Réf. 523777</b> décor imitation chêne nature Natural eiken Nachbildung Eiche natur	<b>Réf. 561786</b> <b>Réf. 523778</b> décor imitation noyer brun Bruin notenhout Nachbildung Nussbaum dunkel	<b>Réf. 545040</b> décor blanc brillant kleur glanzend wit Weiss glänzend
--	---	--	---	--

**Réf. 547346 Réf. 547347 Réf. 547348 Réf. 547349**

décor imitation chêne clair Licht eiken Nachbildung Eiche hell	décor imitation chêne argile Grijsst eiken Nachbildung Eiche lehm	décor imitation chêne nature Natural eiken Nachbildung Eiche natur	décor imitation noyer brun Bruin notenhout Nachbildung Nussbaum dunkel	décor blanc brillant kleur glanzend wit Weiss glänzend
--	---	--	---	--



**0:30**

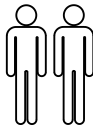

<b>LIT 140x190 BED VAN 140x190 BETT 140x190</b>		<b>Colis Pakket Packstücke</b>	<b>LIT 140x200 BED VAN 140x200 BETT 140x200</b>		<b>Colis Pakket Packstücke</b>	<b>LIT 160x200 BED VAN 160x200 BETT 160x200</b>		<b>Colis Pakket Packstücke</b>	<b>LIT 180x200 BED VAN 180x200 BETT 180x200</b>		<b>Colis Pakket Packstücke</b>
<b>1</b>	1486x900x25 mm	<b>2/2</b>	<b>1</b>	1486x900x25 mm	<b>2/2</b>	<b>1</b>	1686x900x25 mm	<b>2/2</b>	<b>1</b>	1886x900x25 mm	<b>2/2</b>
<b>2</b>	1900x166x25 mm	<b>1/2</b>	<b>2</b>	2000x166x25 mm	<b>1/2</b>	<b>2</b>	2000x166x25 mm	<b>1/2</b>	<b>2</b>	2000x166x25 mm	<b>1/2</b>
<b>3</b>	1486x406x38 mm	<b>1/2</b>	<b>3</b>	1486x406x38 mm	<b>1/2</b>	<b>3</b>	1686x406x38 mm	<b>1/2</b>	<b>3</b>	1886x406x38 mm	<b>1/2</b>

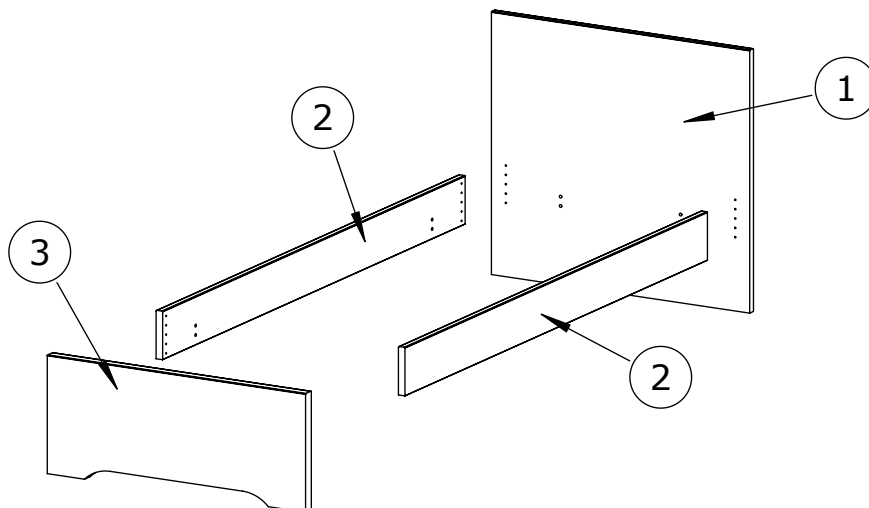

71276

**A**



**16x**

27356 boîte 8 équerres et vis  
Doosje met 8 haakjes en schroeven  
Schachtel mit 8 Winkeln und Schrauben

**B**

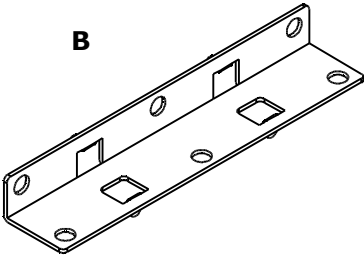

**4x**

**C**

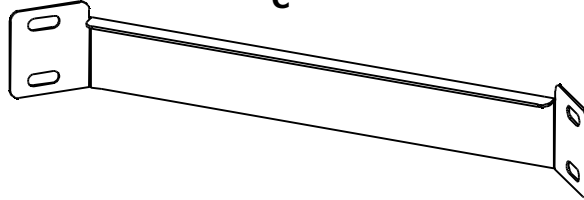

**4x**

**D**



**40x**

**1**

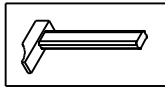

**A**



**8x**

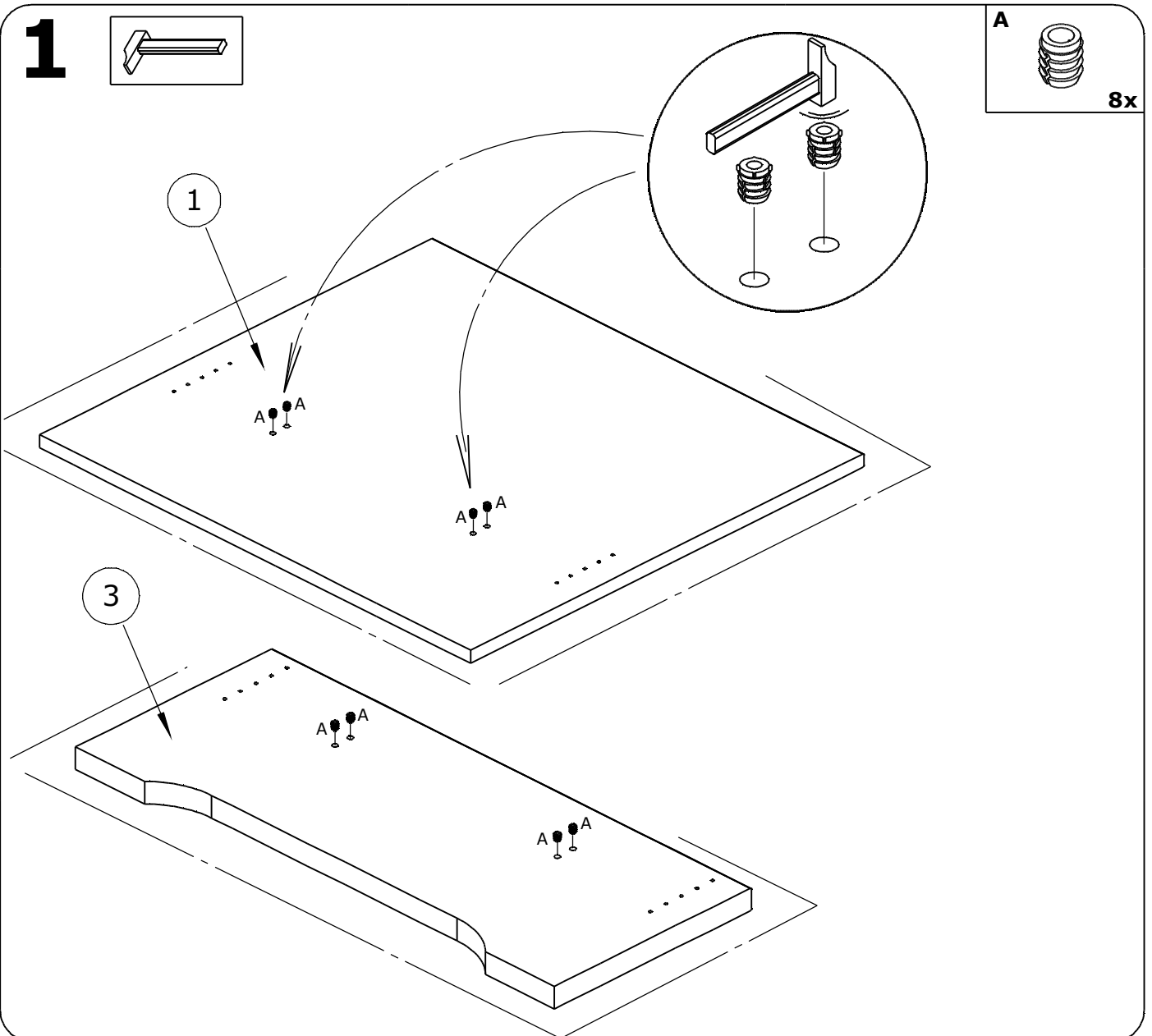

# 2

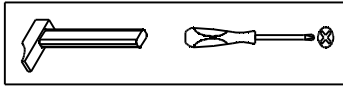
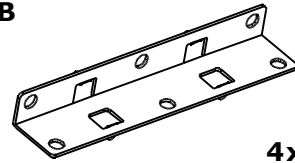
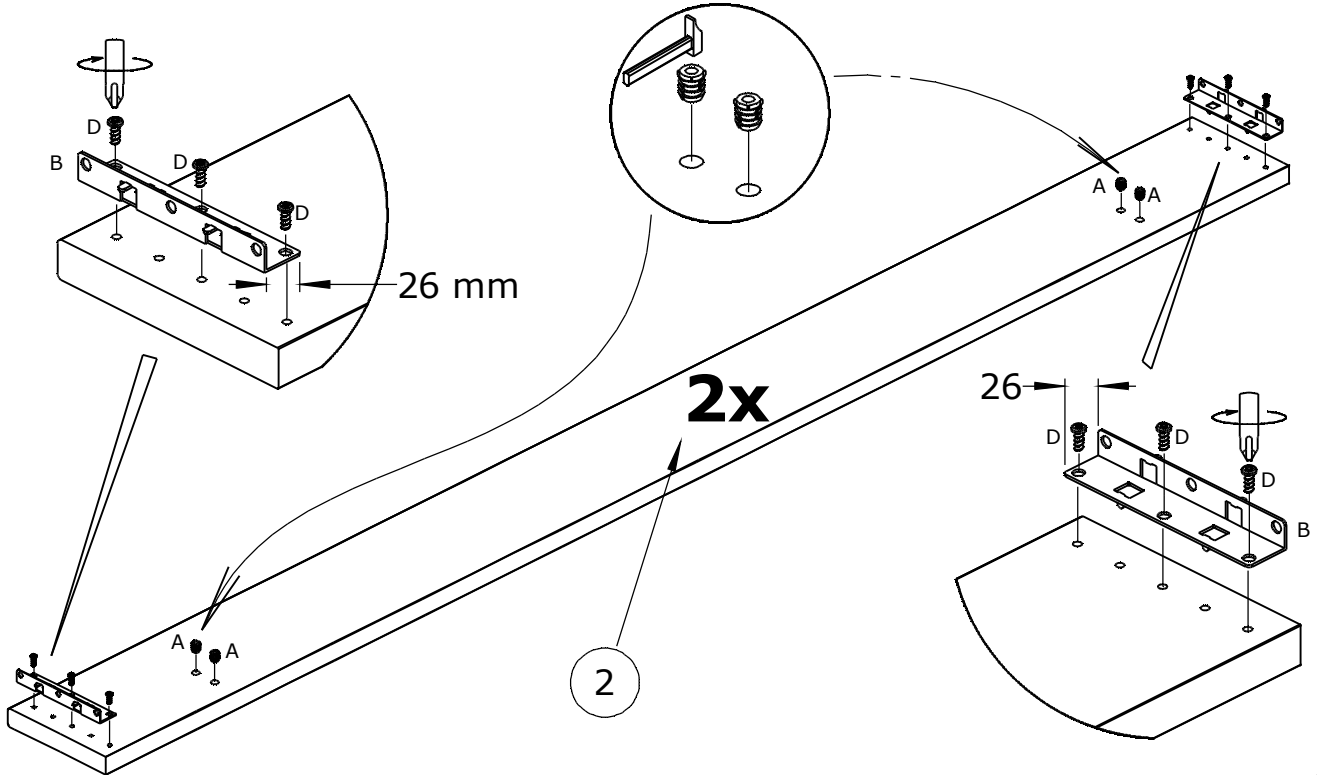
**A****8x****B****4x****D****12x**

## Aménagement haut 2 portes coulissantes Het monteren van 2 schuifdeurtjes aan bovenkant Obere Anbringung der 2 Schiebetüren



### ATTENTION !

Si vous avez opté pour l'aménagement haut 2 portes coulissantes, fixez d'abord la tête de lit n°1 à l'aménagement avant de procéder à l'assemblage de votre lit (lit 140-160-180).  
Démarrez avec étape 2 jusqu'à étape 24 notice de montage aménagement haut 2 portes coulissantes, puis continuez avec étape 3 de cette notice.

### ATTENTIE !

Indien u heeft gekozen voor het meubel met 2 schuifdeurtjes aan de bovenkant, dient u eerst het hoofdeinde van bed n°1 vast te maken aan het meubel voordat u het bed zelf (140-160-180) monteert. Start met etappe 2 tot etappe 24 in de montage-instructies betreffende het monteren van de bovenkant van 2 schuifdeurtjes, om vervolgens verder te gaan met etappe 3 in de montage-instructies.

### ACHTUNG !

Falls Sie sich für eine Obere Anbringung der 2 Schiebetüren entschieden haben, befestigen Sie zunächst das Kopenteil N°1 des Bettes, bevor Sie mit der Bettmontage fortfahren (Bett 140-160-180).  
Beginnen Sie mit dem 2.Schritt bis zum 24.Schritt der Montageanleitung "Obere Anbringung der 2 Schiebetüren" und fahren Sie im Anschluss mit Schritt 3 dieser Montageanleitung fort.

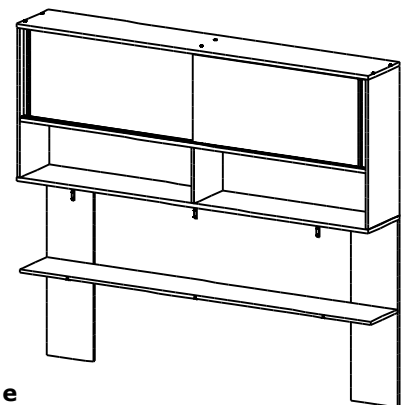

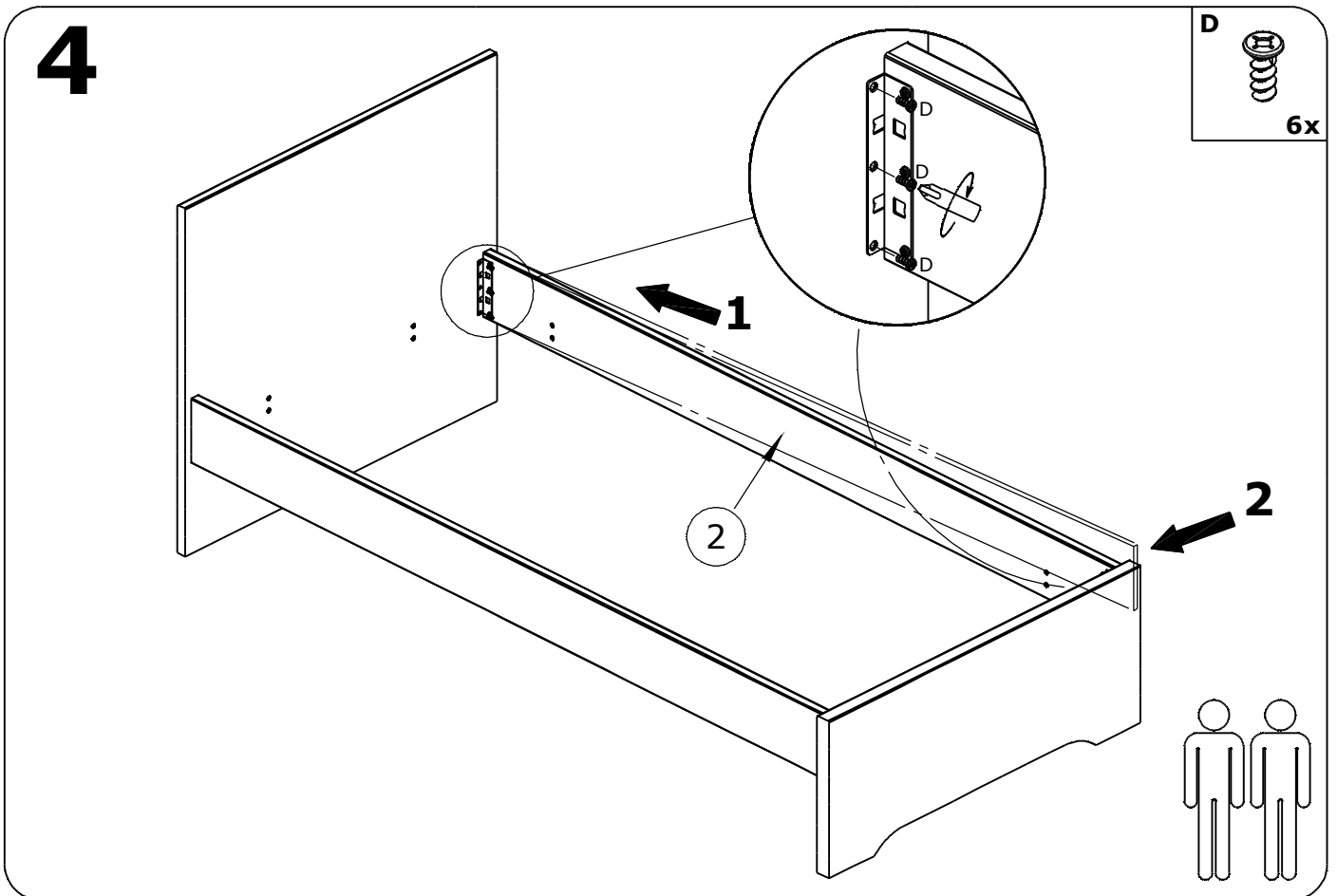
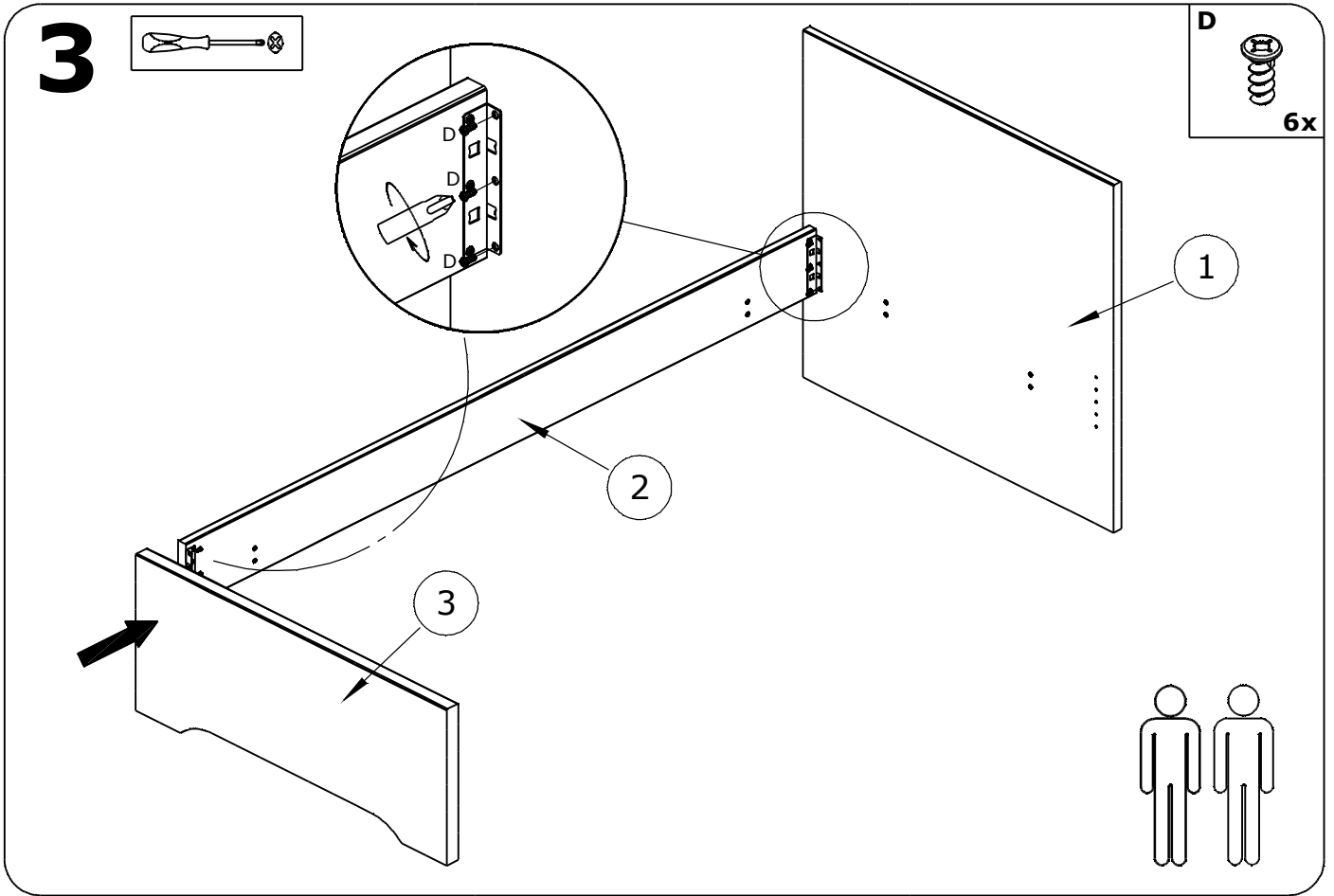

# 5

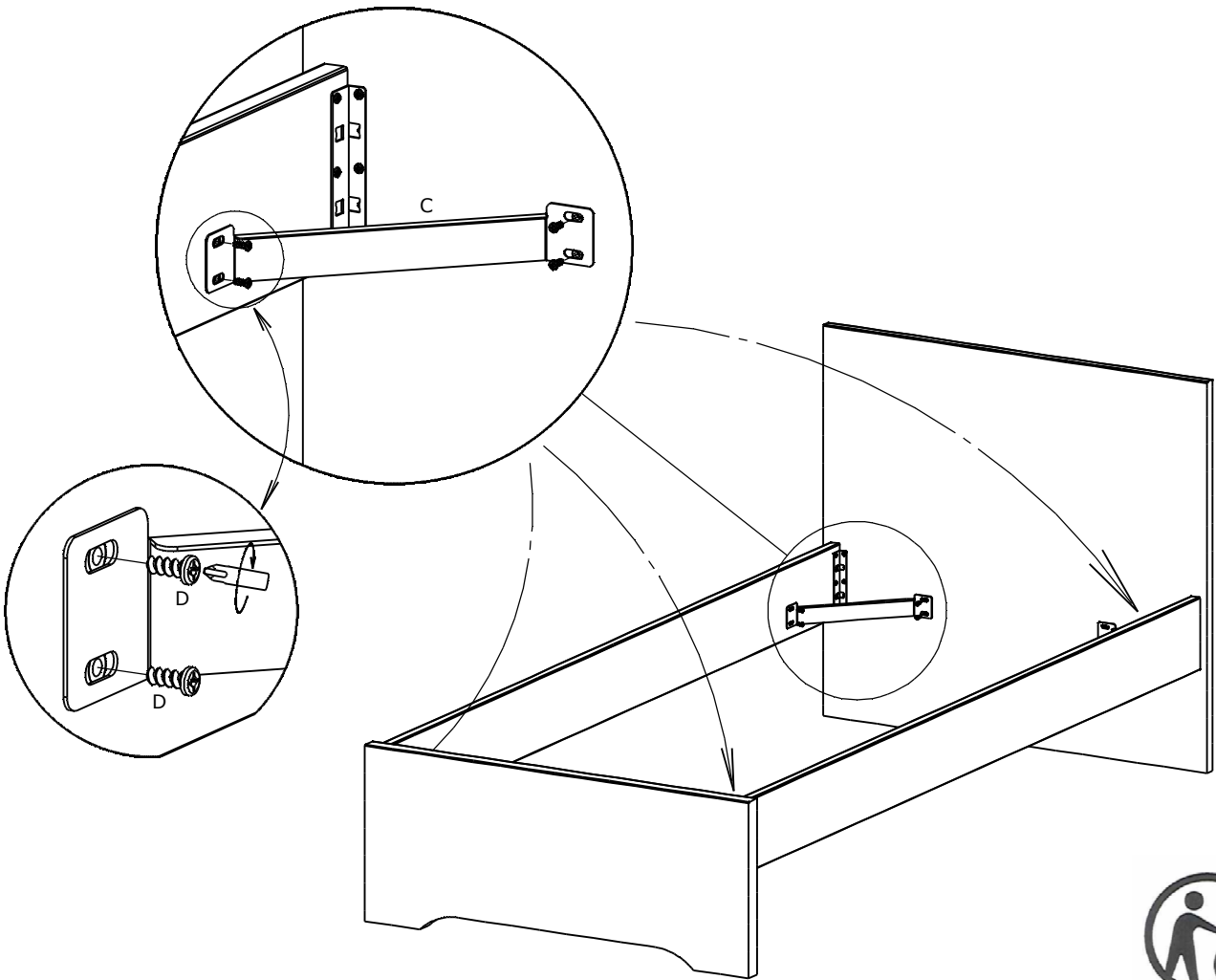
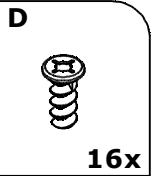
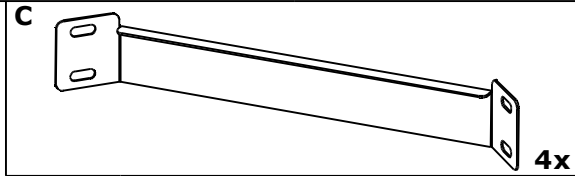
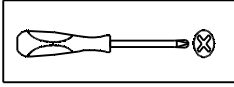

## Veiligheids maatregelen

- 1) Poets uw kast voorzichtig.
- 2) Nooit poetsen met veel water of met schurende produkten.  
Gebruik alleen een klamvochtige doek.  
**LET OP !** Nooit proberen te forceren tijdens de montage van uw kleerkast.  
Mocht er iets ontbreken neem dan de montagehandleiding mee naar uw verkooppunt.

**F CONSEILS D'ENTRETIEN :**

- 1) Dépoussiérez soigneusement.
- 2) Humectez un chiffon doux et propre, d'eau légèrement savonneuse.  
Ne jamais utiliser de produits abrasifs : poudre, laine d'acier, solvants.  
Ne pas mouiller copieusement.



**NE JAMAIS FORCER LES ASSEMBLAGES  
RESSERRER LES VIS APRES QUELQUES TEMPS D'USAGE  
GARDER VOTRE NOTICE DE MONTAGE, SI UNE PIECE  
VENAIT A MANQUER, ELLE SERAIT LE PLUS CLAIR MOYEN  
DE COMMUNIQUER AVEC VOTRE MAGASIN.**

**GB NOTICE FOR MAINTENANCE :**

- 1) Dust of carefully.
- 2) Use a soft, proper and humid duster and light soap solution to clean the furniture.  
Please do not use any scouring agent like powder, steel wool, solvents.  
Do not wet too much.



**NEVER FORCE THE CONNECTIONS  
RE-TIGHTEN THE SCREWS AFTER FEW DAYS.  
PLEASE RETAIN THE AI LEAFLET FOR FUTURE REFERENCE,  
THE AI CONTAINS INFORMATION WHEN CLAIMING  
FOR MISSING PARTS.**

**D PFLEGEHINWEISE :**

- 1) Sorgfältig entstauben.
- 2) Mit einem weichen, sauberen und feuchten Tuch und leichter Seifenlauge reinigen.  
Benutzen Sie keine Scheuermittel wie Pulver, Stahlwolle, Lösungsmittel.  
Nicht zu nass abwischen.



**NIEMALS DIE VERBINDUNGEN ZU STARCK ANZIEHEN  
DIE SCHRAUBEN NACH EINIGER ZEIT DES GEBRAUCHS  
ERNEUT FESTZIEHEN. DIE MONTAGEANLEITUNG GUT  
AUFBEWAHREN, SOLLTE EIN TEIL FEHLEN , IST SIE DAS  
BESTE VERSTÄNDIGUNGSMITTEL MIT IHREM GESCHÄFT.**

**I CONSIGLI PER LA MANUTENZIONE :**

- 1) Spolverate accuratamente.
- 2) Inumidire con acqua leggermente insaponata uno straccio morbido e pulito.  
Non utilizzare mai prodotti abrasivi : polvere, lana di acciaio, solventi.  
Non bagnare troppo.



**NON FORZARE MAI GLI ASSEMBLAGGI  
RISTRINGERE LE VITI DOPO UN PERIODO D'USO  
CONSERVARE QUESTE ISTRUZIONI DI MONTAGGIO, SE  
UN PEZZO VENISSE A MANCARE SAREBBE IL MIGLIORE  
MEZZO DI COMUNICAZIONE CON IL RIVENDITORE.**

**E RECOMENDACIONES PARA EL MANTENIMIENTO :**

- 1) Despolvorear cuidadosamente.
- 2) Humedecer un pano suave y limpio con agua ligeramente enjabonada.  
No use nunca productos abrasivos tales como : polvo de limpiar, lana de acero, solventes.  
No mojar exageradamente.



**NO FUERCE NUNCA EN LAS UNIONES . APRIETE LOS  
TORNILLOS DESPUES DE CIERTO TIEMPO DE UTILIZACION  
CONSERVE SU MANUAL DE MONTAJE, SI FALTARA UNA  
PIEZA, SERIA LA MANERA MAS FACIL DE COMUNICAR  
CON LA TIENDA.**

**P NORMAS DE MANUTENCAO :**

- 1) Eliminar bem o po.
- 2) Umedecer um pano suave e limpo com agua e um pouco de sabao.  
Nunca utilizar produtos abrasivos : pos, la de aço, solventes.  
Nao molhar demasiado.



**NUNCA FORCAR OS ENCAIXES.REAPERTAR OS  
PARAFUSOS APOS UM TEMPO DE UTILIZACAO.  
GUARDAR AS INSTRUCOES DE MONTAGEM.  
CASO FALTE ALGUMA PECA , O MAIS A CONSELHABEL  
E CONTATAR O REVENDEDOR.**

**TR BAKIM TALIMATLARI :**

- 1) Tozunu dikkatlice aliniz.
- 2) Yumusak bir bezi temiz su ve az miktarda sabunla (deterjan) nemlendiriniz  
- Asla asındirici ürünler kullanmayiniz : Celik yünü, solvent  
- Bol suyla yikamayiniz.



**MONTAJLARI ZORLAMAYINIZ.  
BIRKAC KULLANIMDAN SONRA VIDALARI SIKISTIRINIZ.  
BIR PARCANIN KAYBOLMASI DURUMUNDA MAGAZANIZ-  
LADAH KOLAY ILETISIME GECEBILMENIZ ICIN MONTAJ  
KULLANIM TALIMATINIZI SAKLAYINIZ.**

**HR UPUTE ZA ODRZAVANJE :**

- 1) Pazljivo obrisati prasinu.
- 2) Koristite suhu krpu.  
- Zabranjena je upotreba kemikalija ili bilo kakvih pomocnih sredstava za ribanje jakih sredstava za ciscenje ili celigne vune  
- Ne mokra.



**NEMOJTE UPOTREBLJAVATI SILU PRILIKOM SKLAPANJA  
NAKON NEKOG VREMENA PONOVRNO PRITEGNITE VIJKE  
CUVAJTE UPUTE ZA MONTAZU  
U SLUCAJU NEDOSTATKA NEKOG DIJELA NAJBOJE CE BITI  
DA KONTAKIRATE PRODAJNO MJESTO.**