

**NOTICE DE MONTAGE
ASSEMBLING INSTRUCTIONS
MONTAGEANLEITUNG
ISTRUZIONI DI MONTAGGIO
INSTRUCCIONES DE MONTAJE
INSTRUCCIONES DE MONTAJE
UPUTE ZA MONTAZU
MONTAJ TALIMATI**

Armoire 4 portes 2 tiroirs

Réf. 561803 Réf. 561804 Réf. 561805 Réf. 561806
Réf. 523757 Réf. 523760 Réf. 523761 Réf. 523762
 décor imitation chêne clair décor imitation chêne argile décor imitation chêne nature décor imitation noyer brun

Réf. 548831
 décor blanc brillant

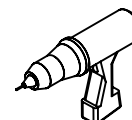
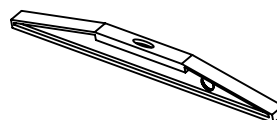
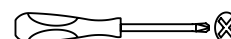
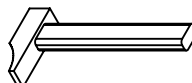
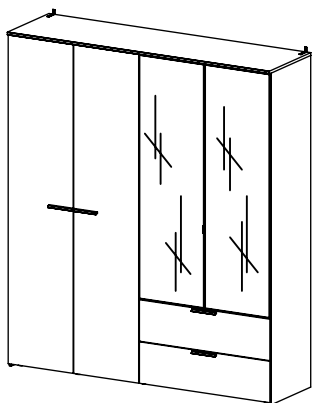

N°	Dimensions	Colis	N°	Dimensions	Colis	N°	Dimensions	Colis
1	1968x525x15 mm	2/4	19	2254x990x3 mm	4/4	13	401x165x13 mm	1/4
2	2271x525x15 mm	3/4	8	1999x550x19 mm	4/4	14	955x400x3 mm	1/4
3	2241x505x15 mm	3/4	9	977x430x19 mm	1/4	15	944x165x13 mm	1/4
4	977x430x19 mm	1/4	10	970x30x15 mm	1/4	20	1671x496x18 mm	2/4
5	2271x525x15 mm	3/4	11	996x284x15 mm	1/4	17	2250x496x15 mm	4/4
6	977x505x19 mm	1/4	12	401x165x13 mm	1/4			

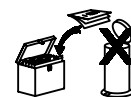
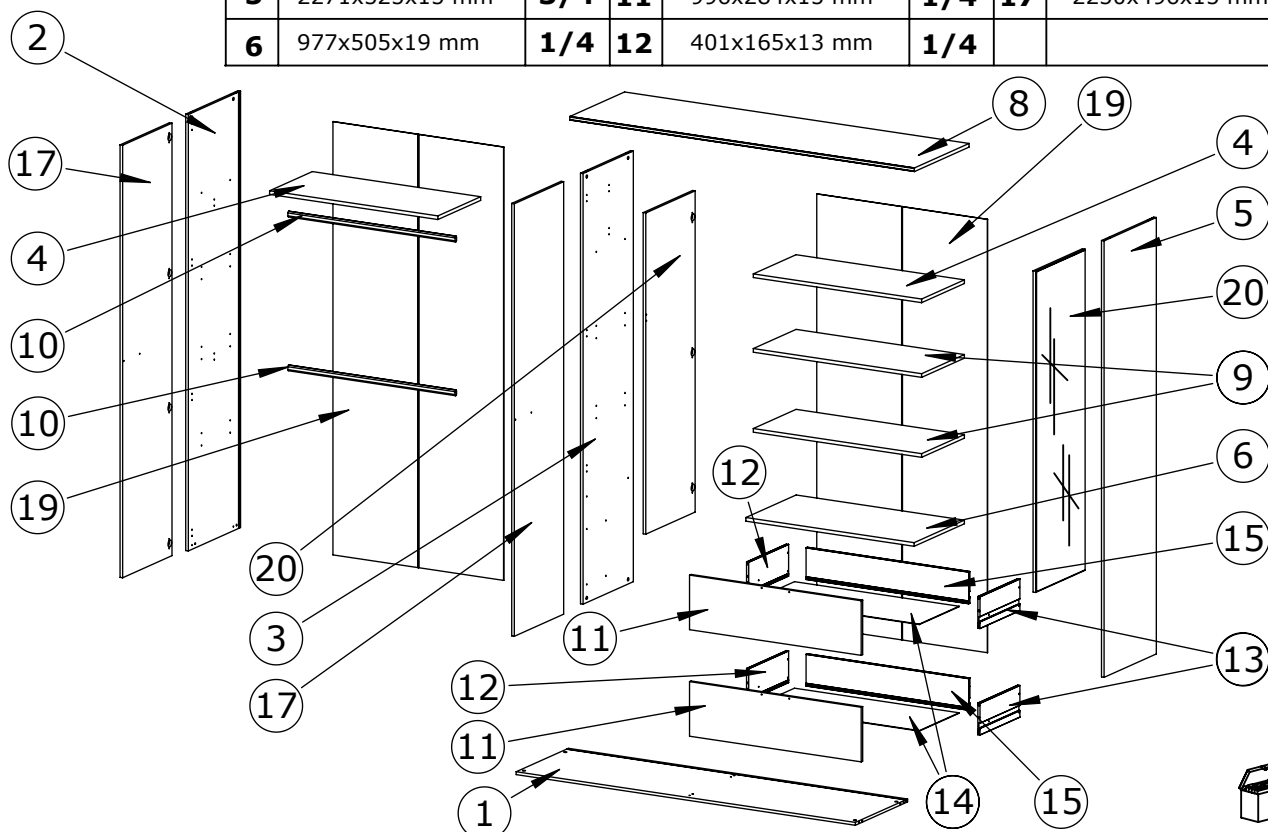

		<p>A 24x ø8x30 mm (12920)</p>	<p>500617 J 12x</p>	<p>52259 K 22x</p>	
<p>B 12x (504029)</p>	<p>D 21x ø3,5x15 mm (31602)</p>	<p>F 4x M4x9 mm (38646)</p>	<p>28403 L 12x</p>	<p>22391 M 12x</p>	
<p>G 12x ø3x20 mm (14141)</p>	<p>H 8x ø6,6x40 mm (482719)</p>	<p>I 8x ø6,3x11 mm (31625)</p>	<p>452549 N 2x</p>	<p>27421 O 8x</p>	<p>30046 P 4x</p>
			<p>1602654 Q 6x</p>	<p>52563 R 2x</p>	
			<p>2007937 S 9x</p>	<p>457143 T 2x</p>	
<p>550365 U1 14x</p>	<p>550366 V1 7x</p>	<p>35838 C 3x</p>	<p>550367 X1 7x</p>		
<p>523748 Y 4x</p>	<p>523825 Z Z1 1x</p>	<p>33769 A1 2x 2 pièces</p>			

1

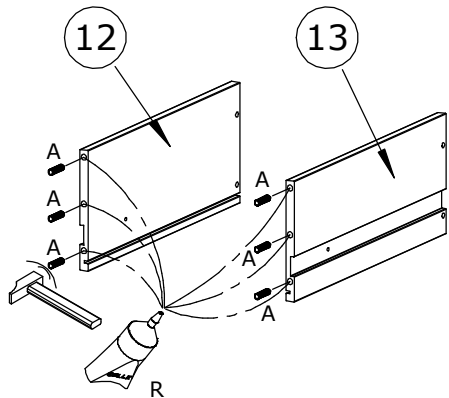
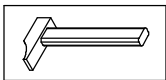

A $\varnothing 8 \times 30$ mm



12x

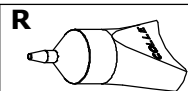

1x

2x

2

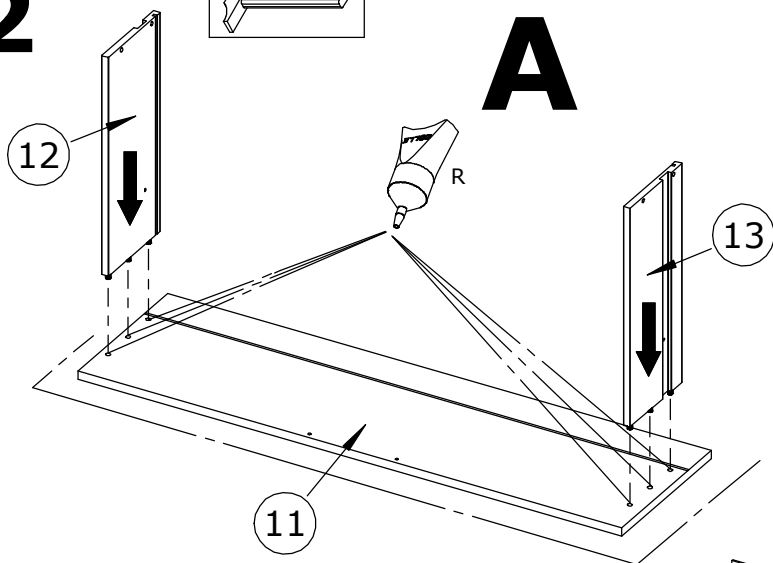
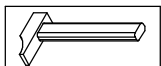

H L=40 mm

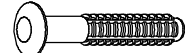

8x



1x

2x

B

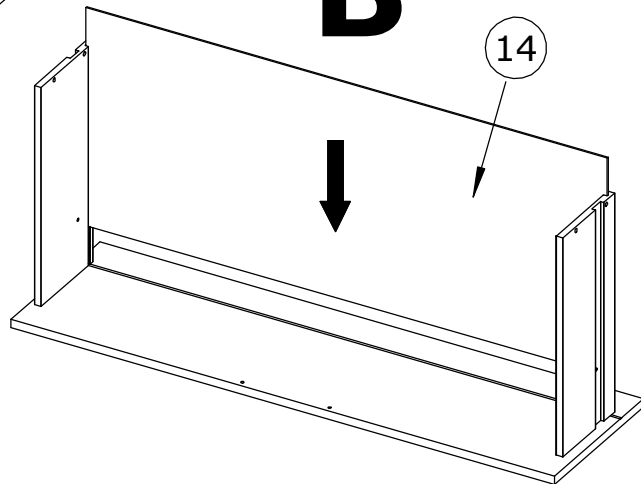

2x

C

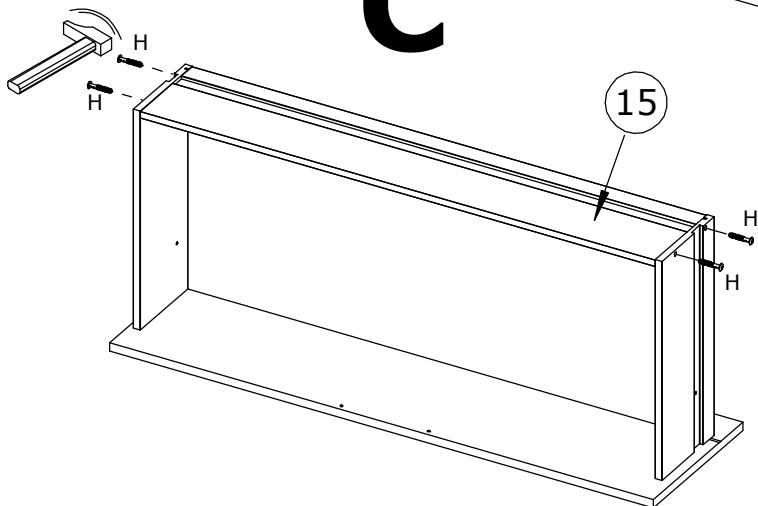

2x

3

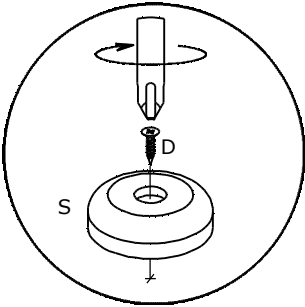
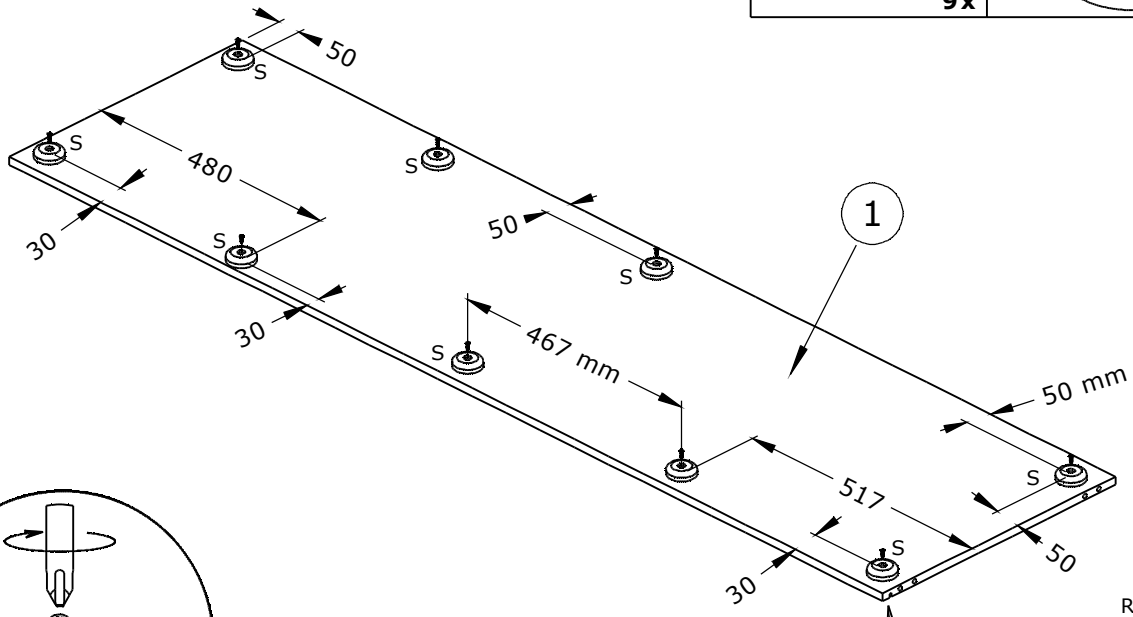
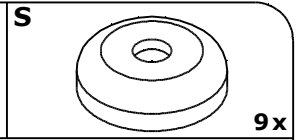
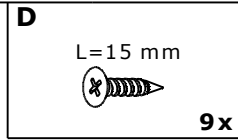
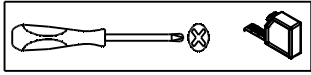

1 Pointer
2 Visser

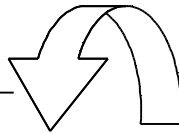

4

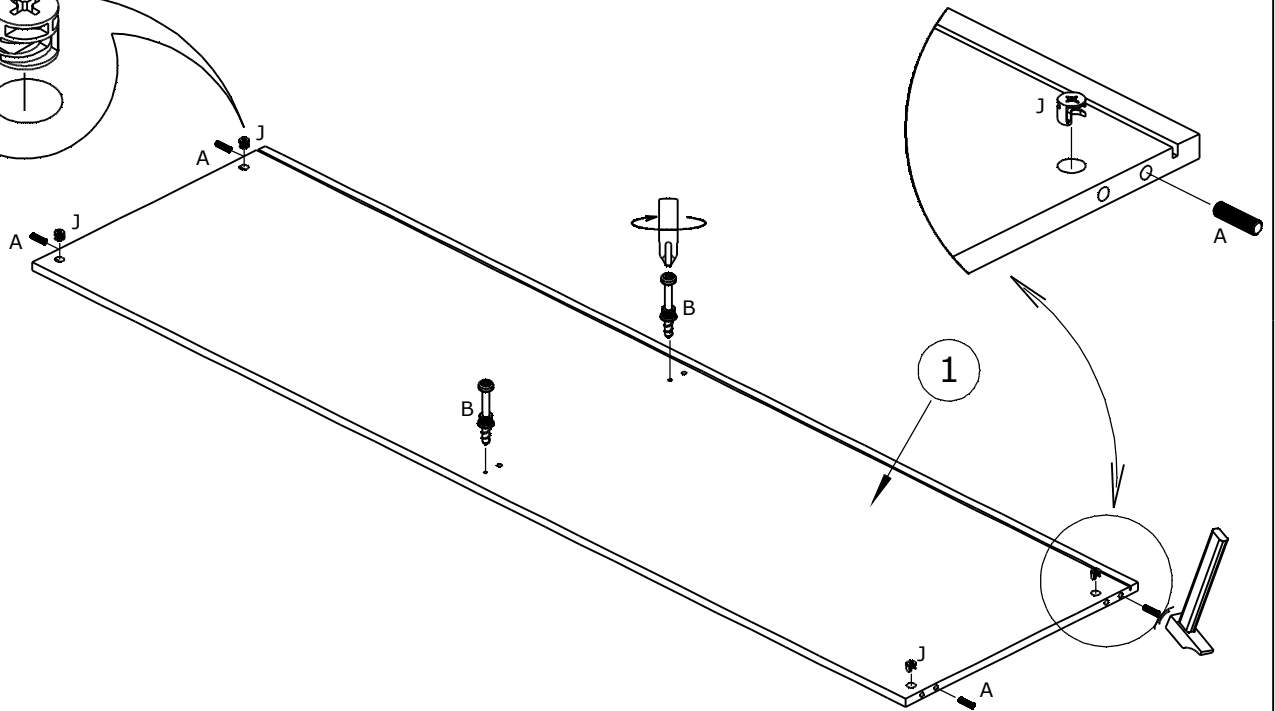
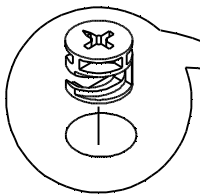
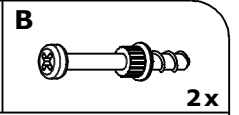
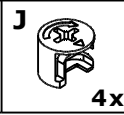
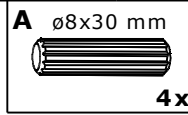
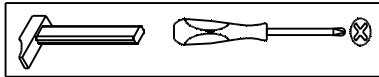

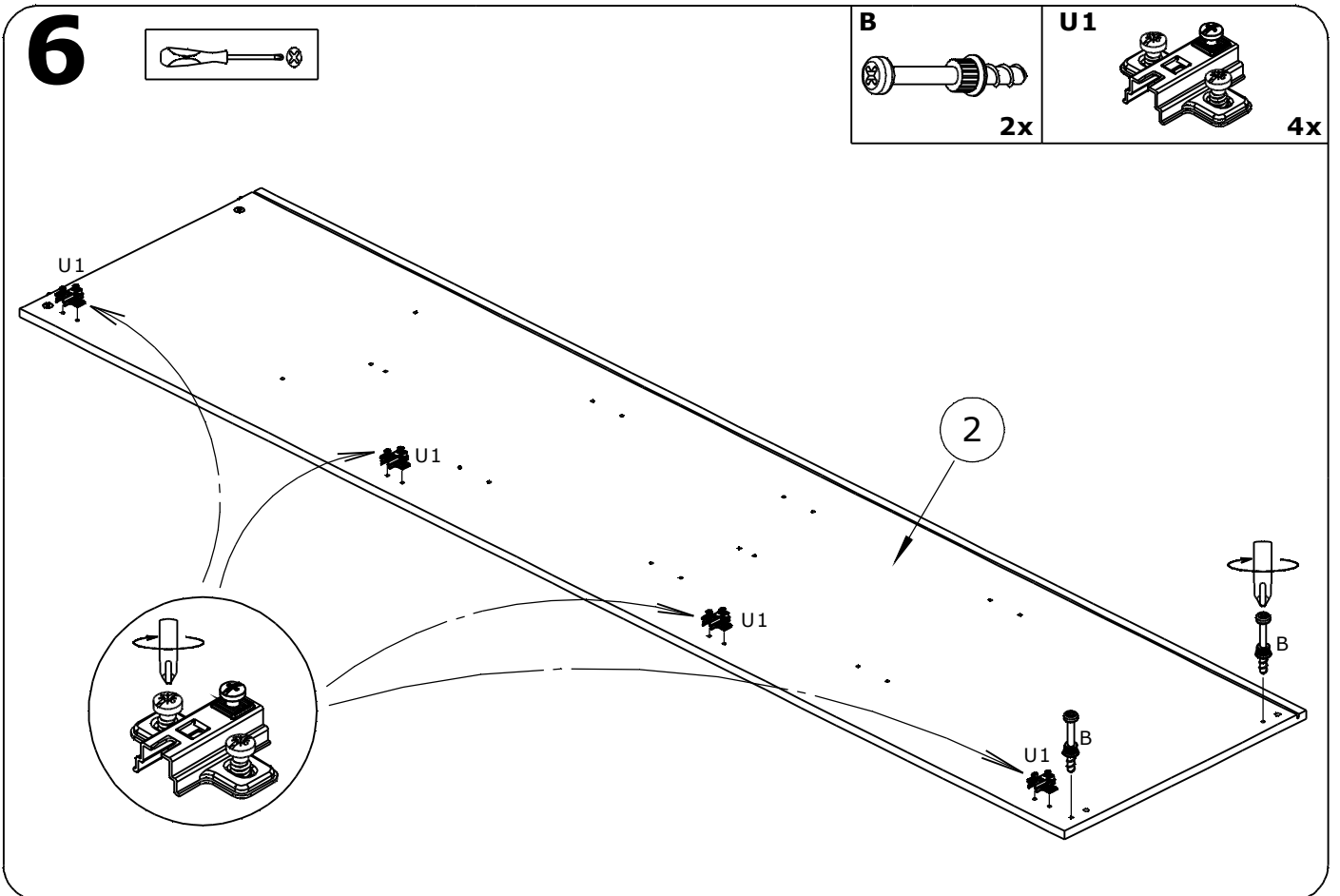
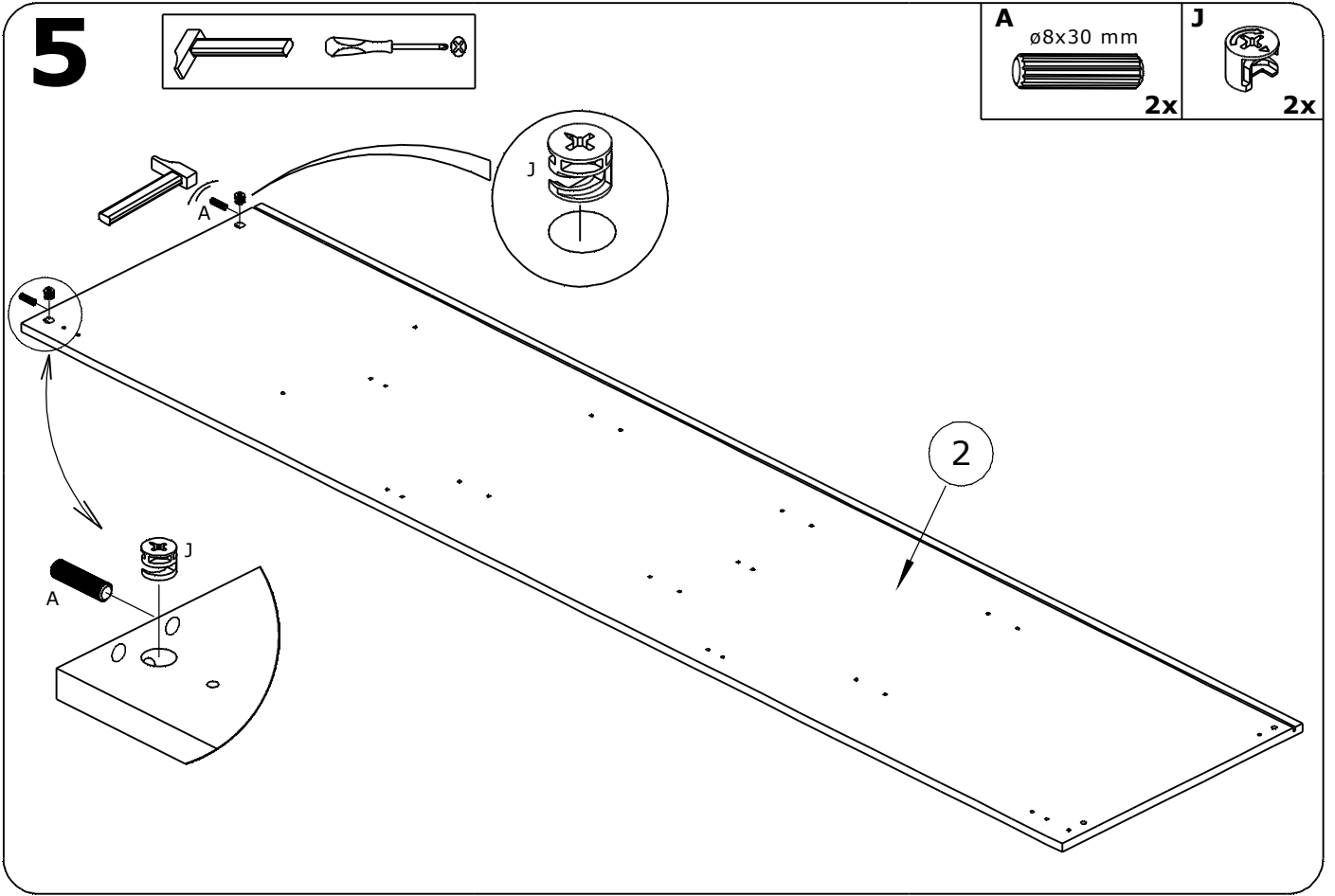

7

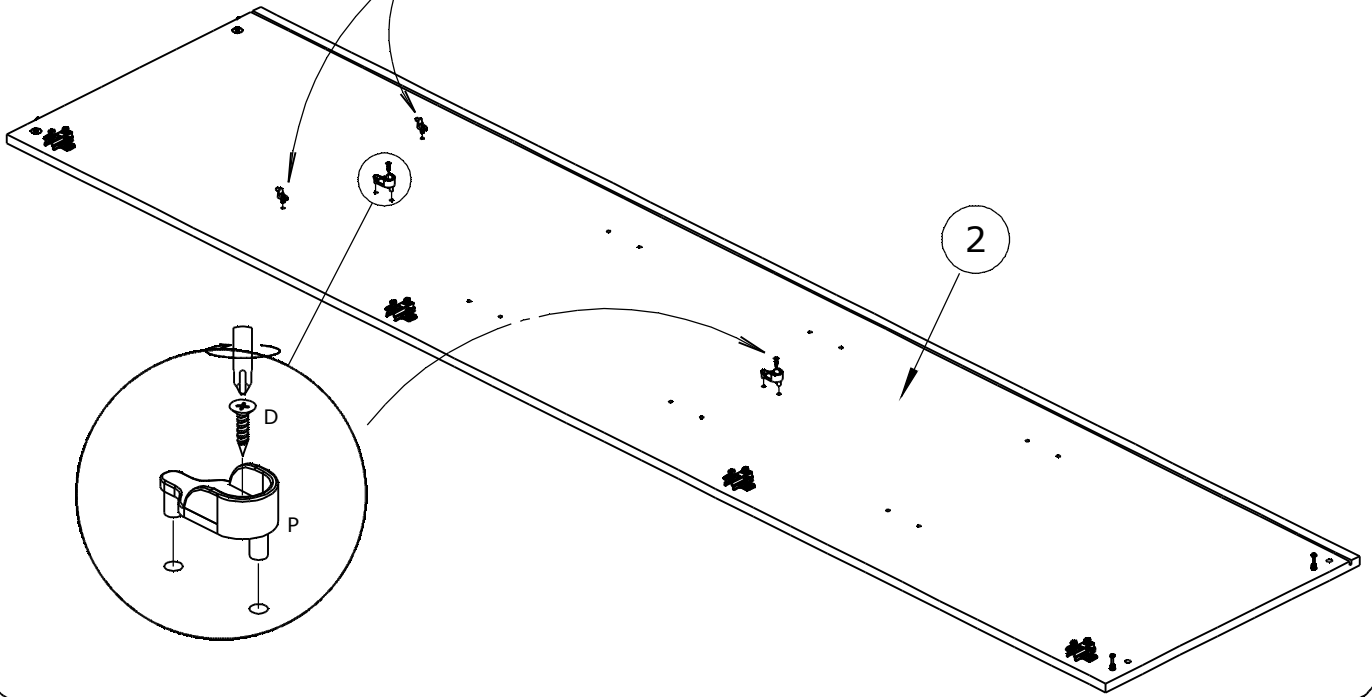
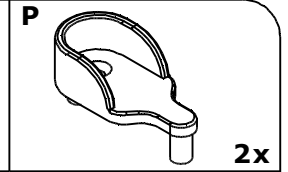
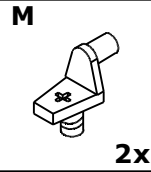
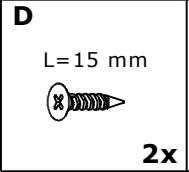
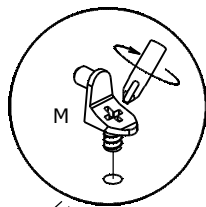
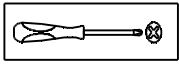

8

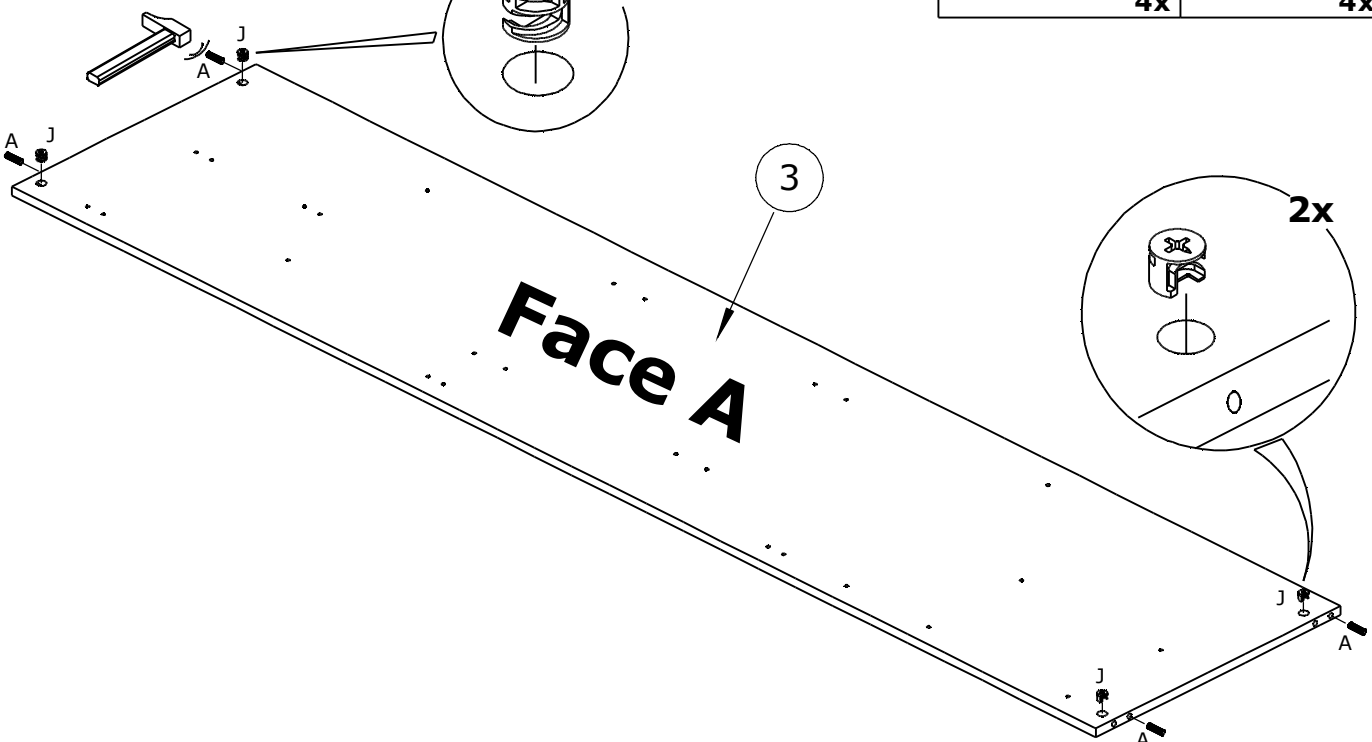
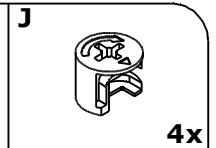
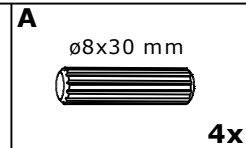
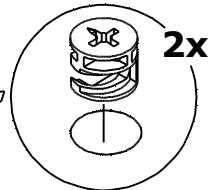
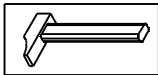

9

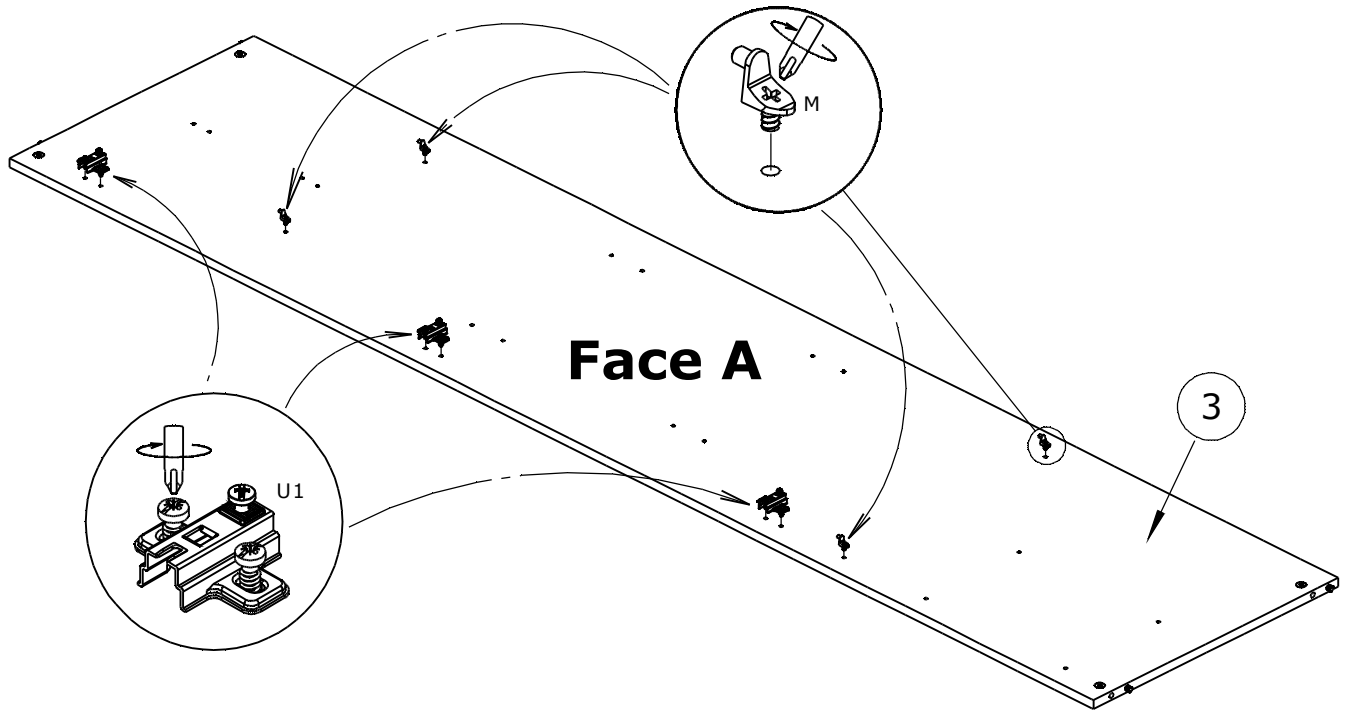
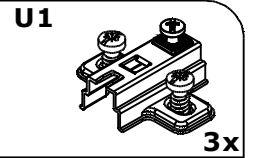
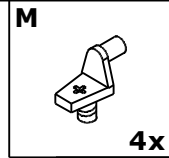
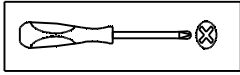

10

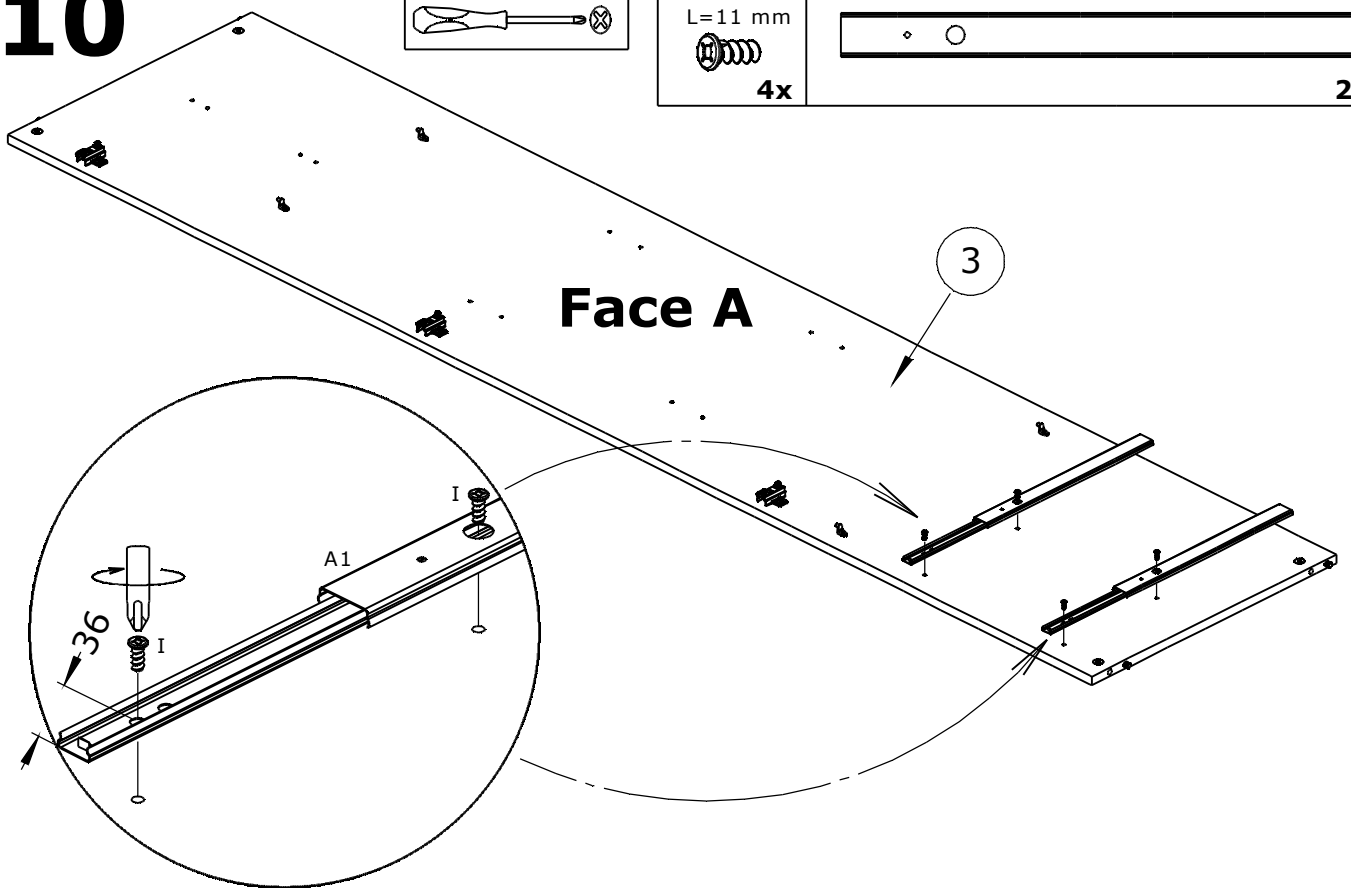
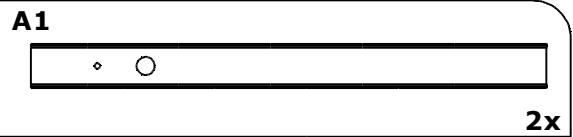
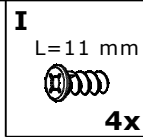
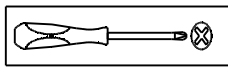

11

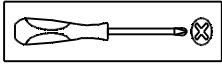
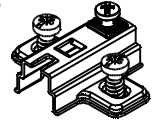
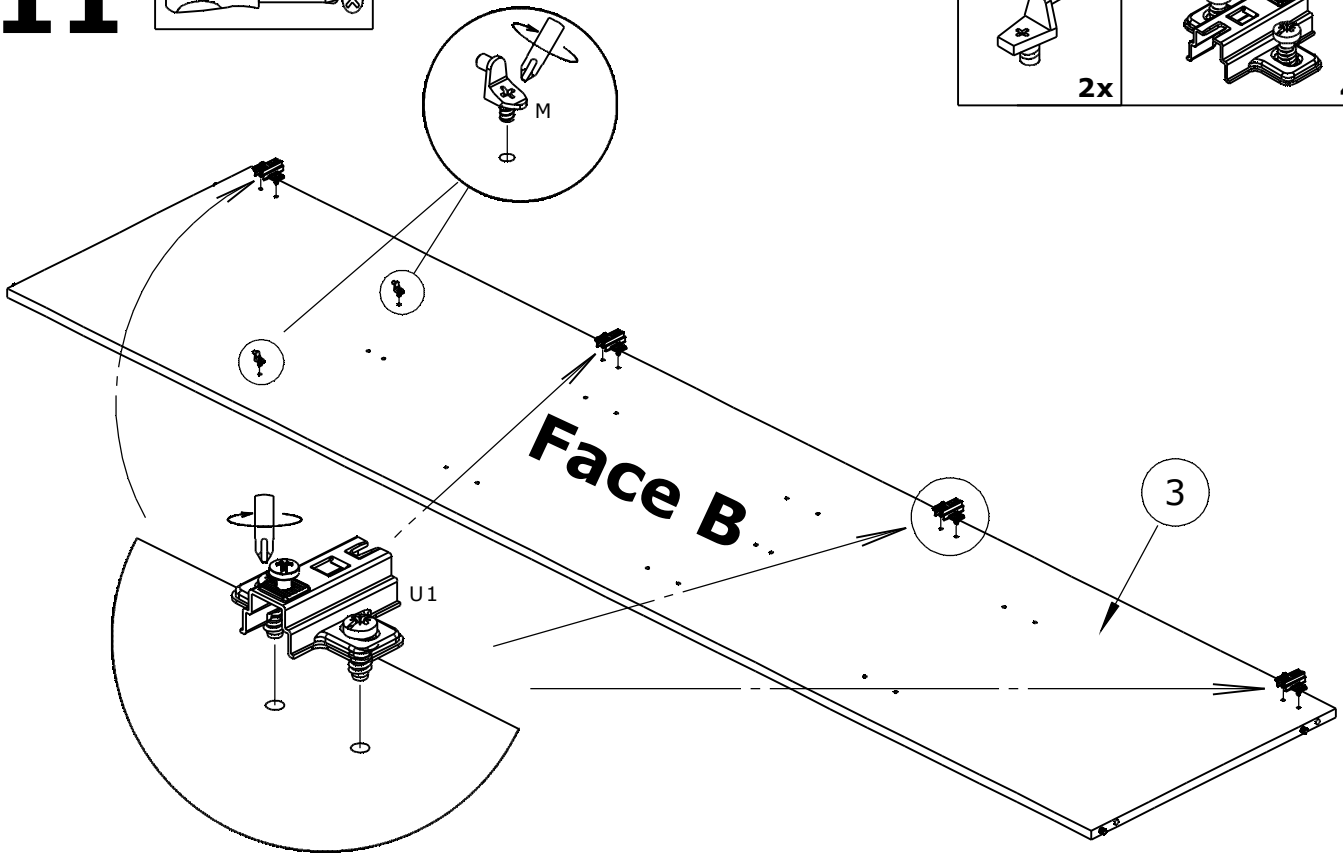
**M****2x****U1****4x**

12

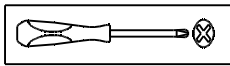
**D**

L=15 mm

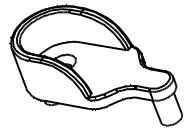
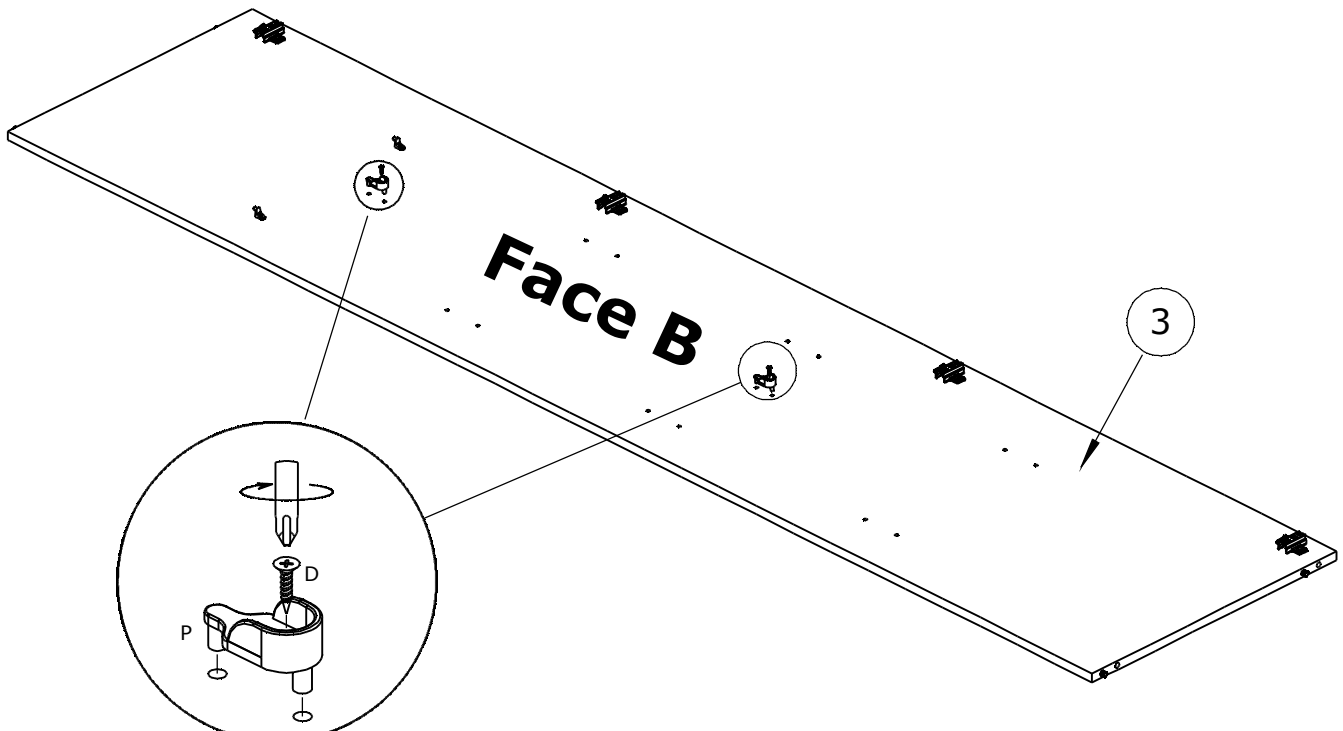
**2x****P****2x**

13

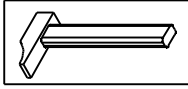

A $\varnothing 8 \times 30$ mm



2x

J



2x

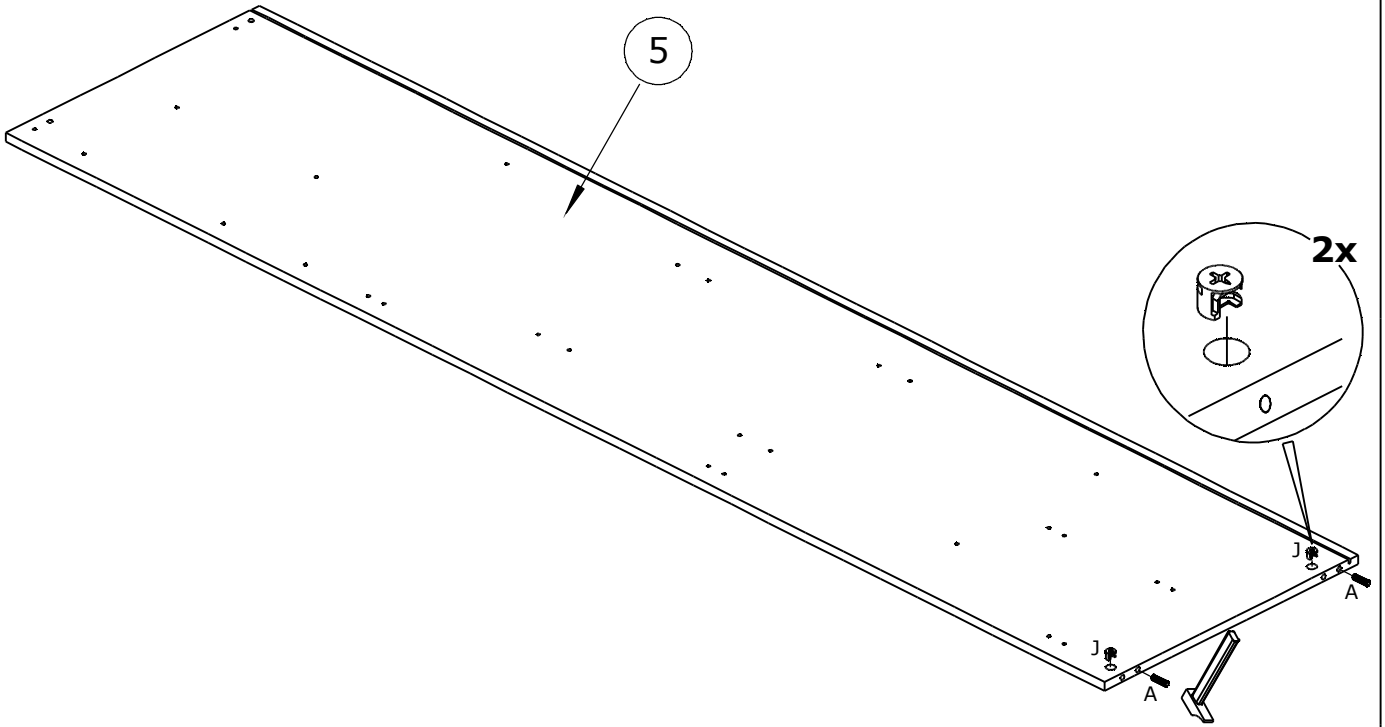

14

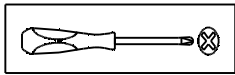

B

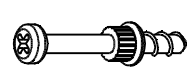

2x

U1

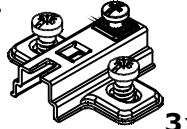

3x

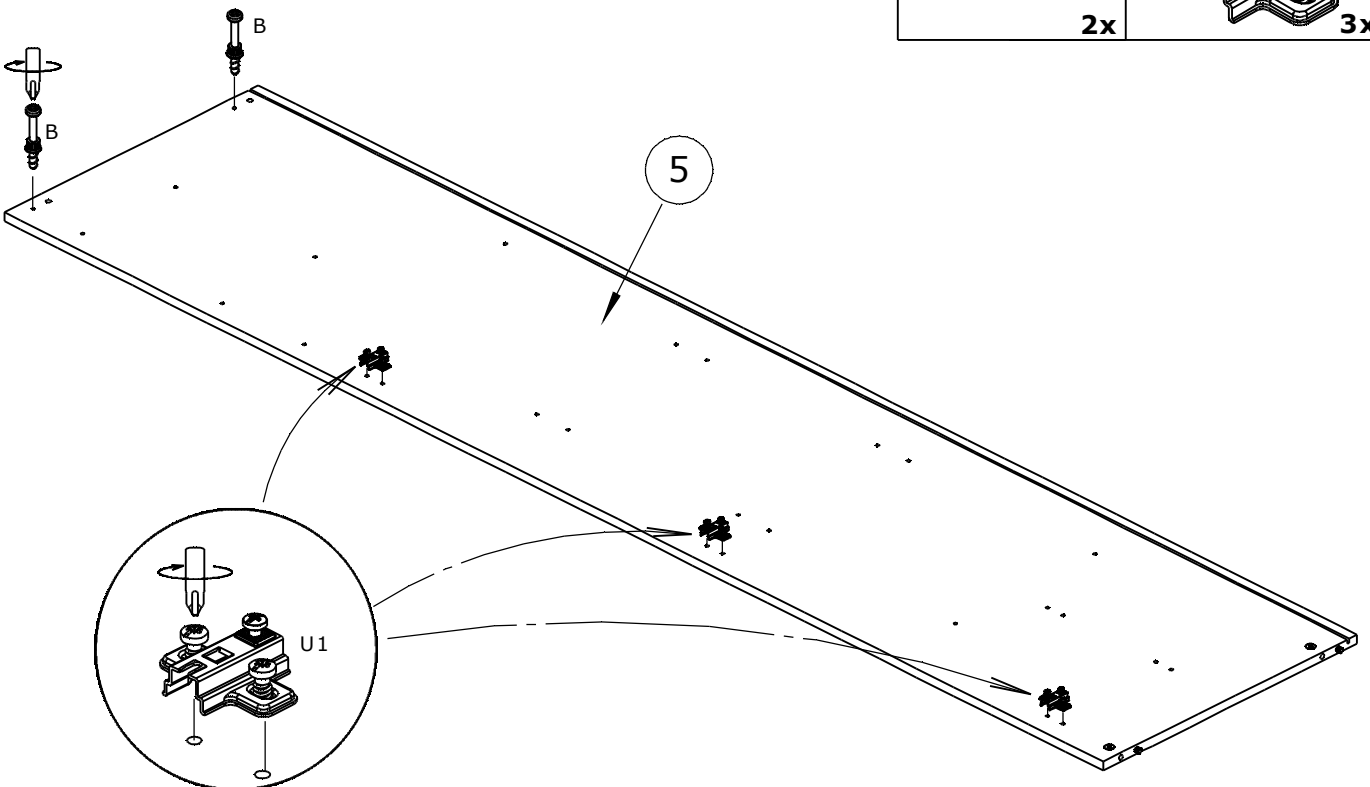

15

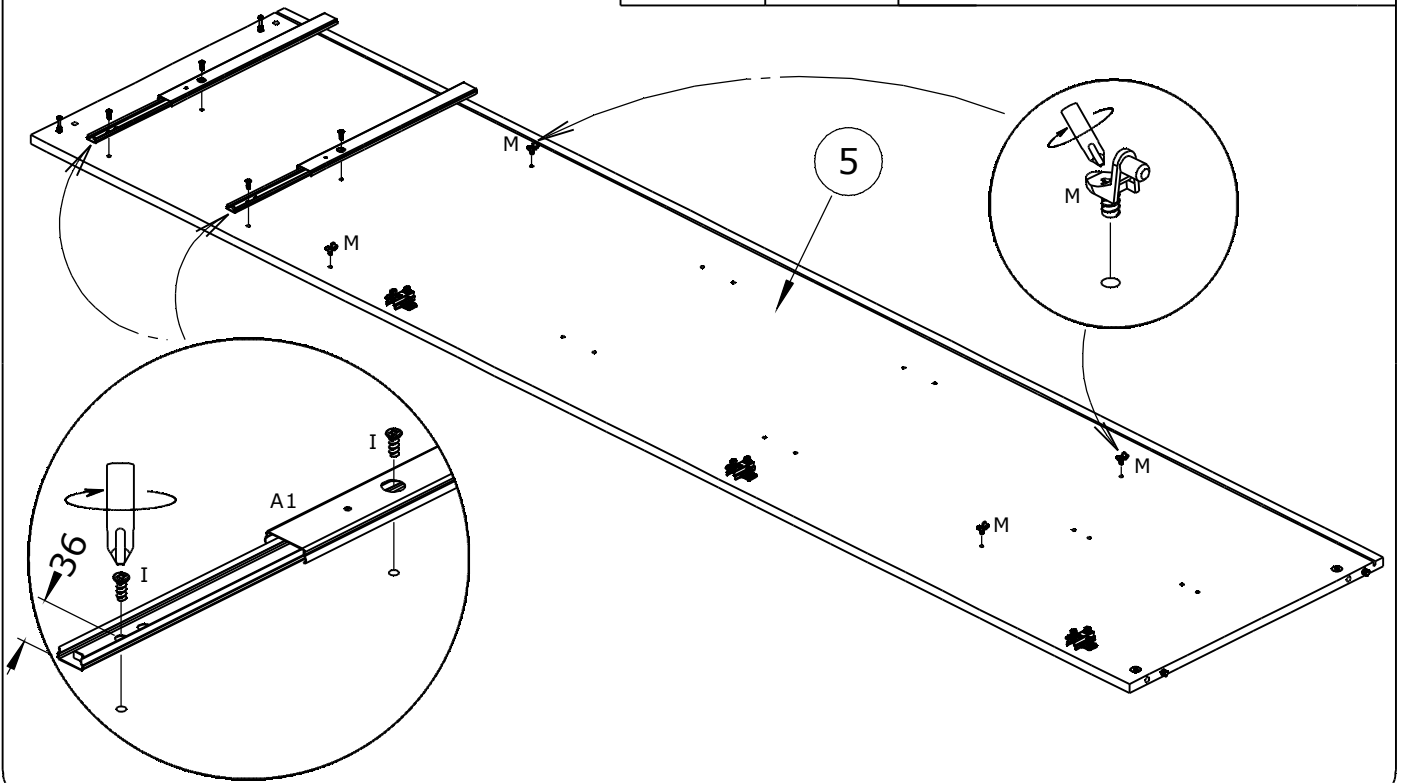
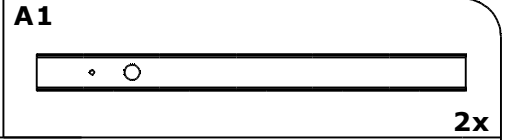
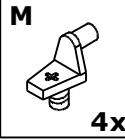
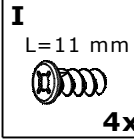
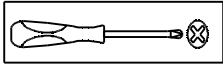

16

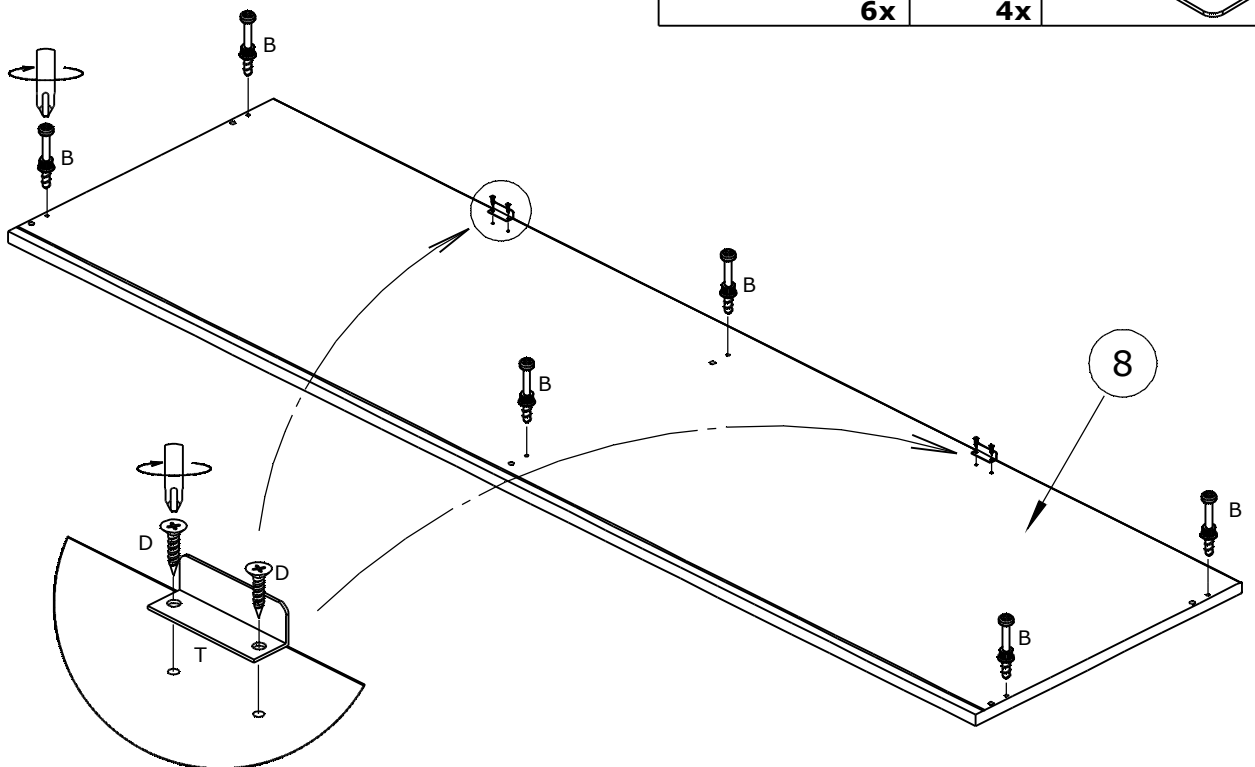
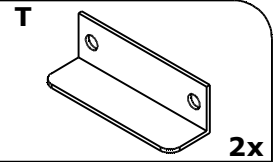
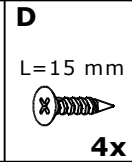
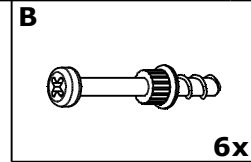
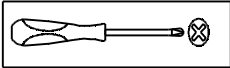

17

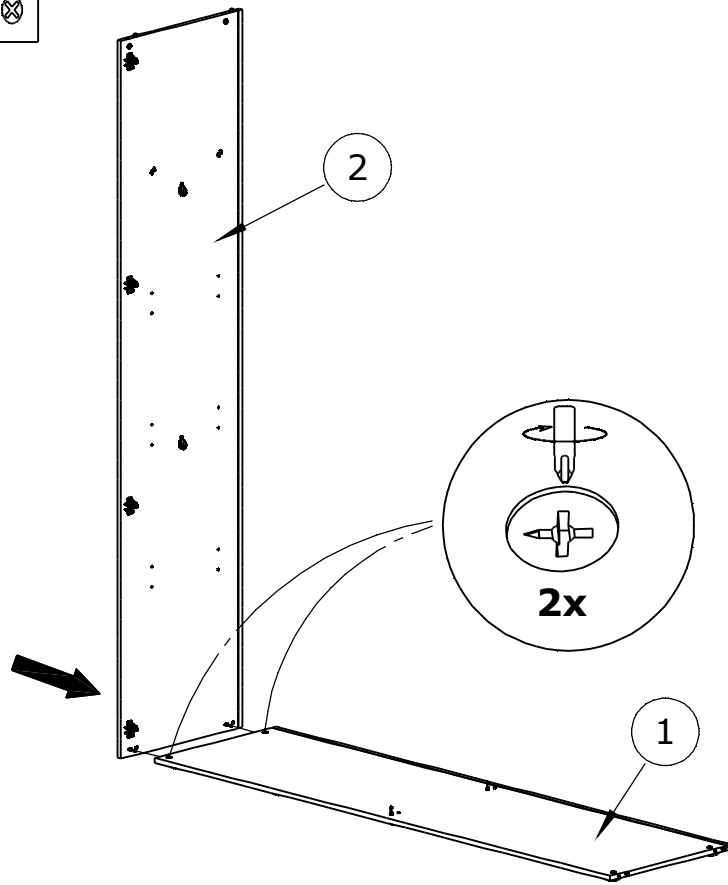
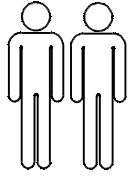
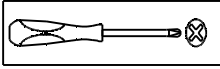

18

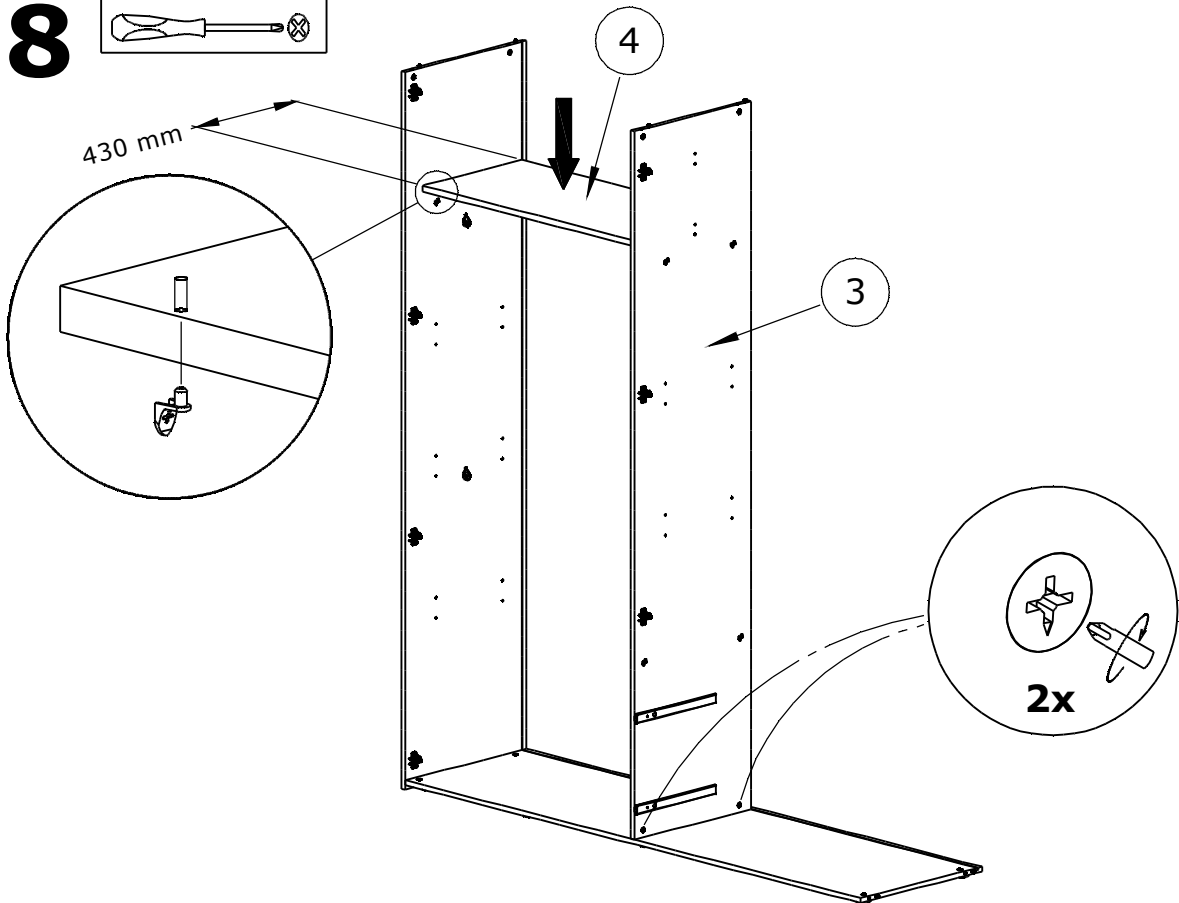
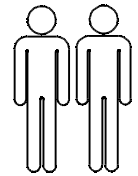
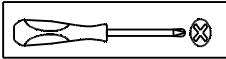

19

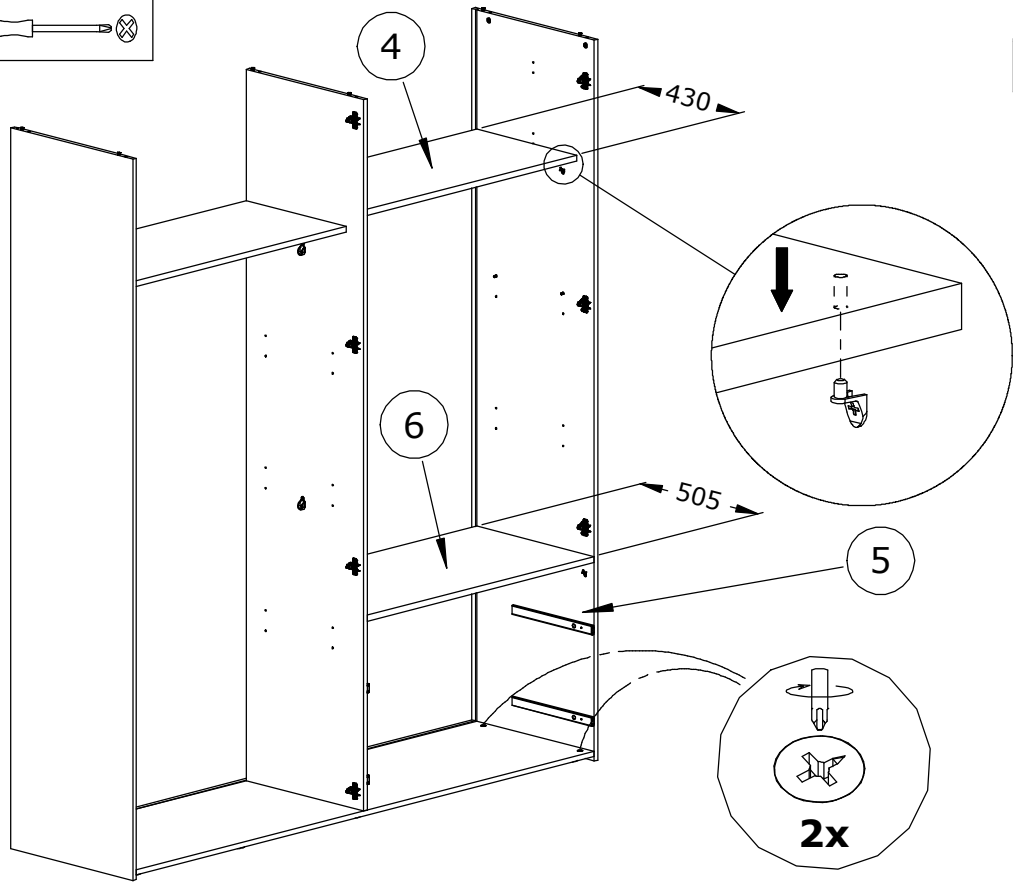
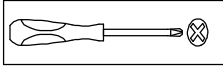

20

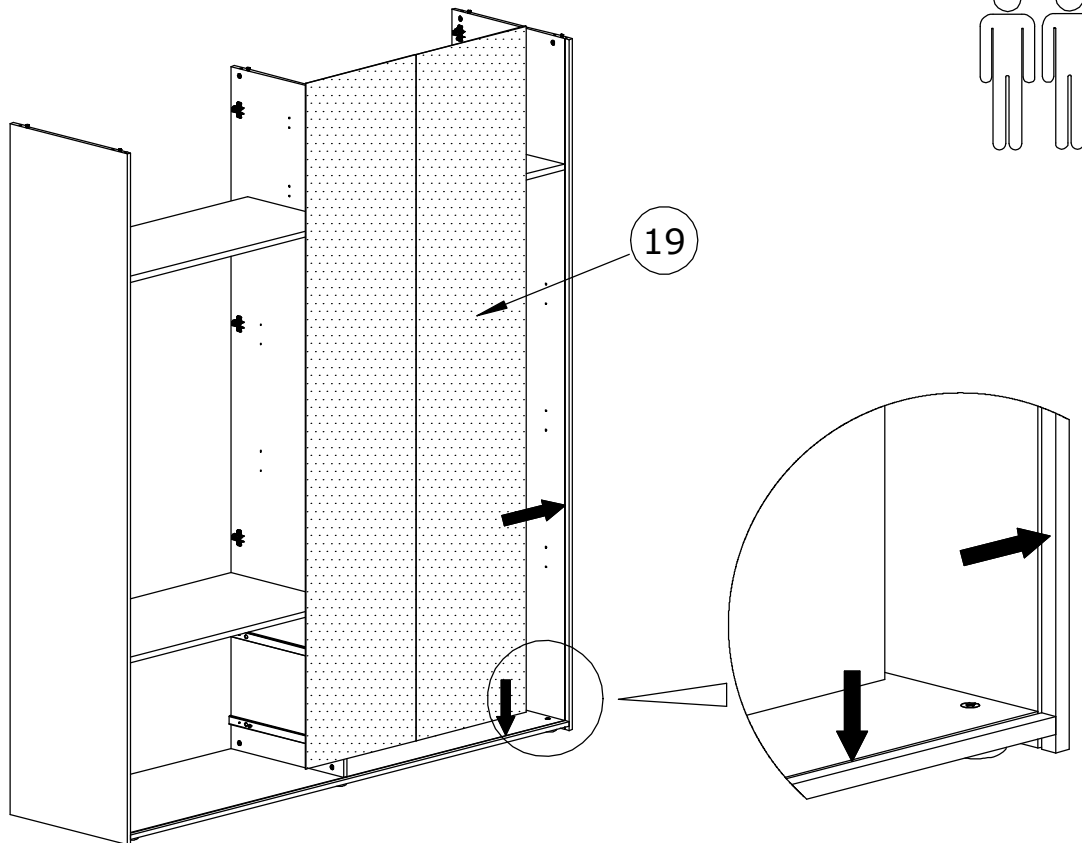

21

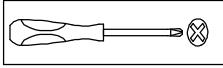

90°

K

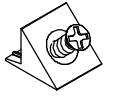

5x

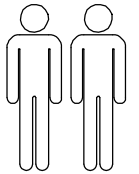
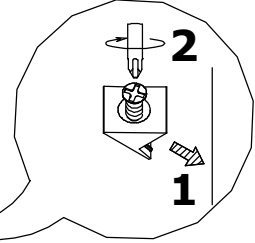
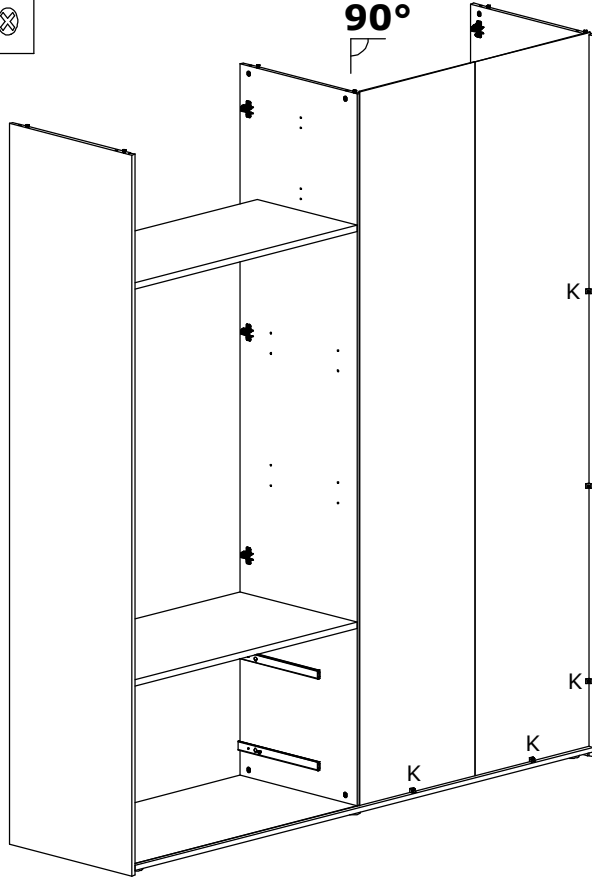

22

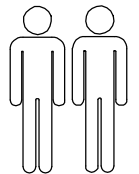

19

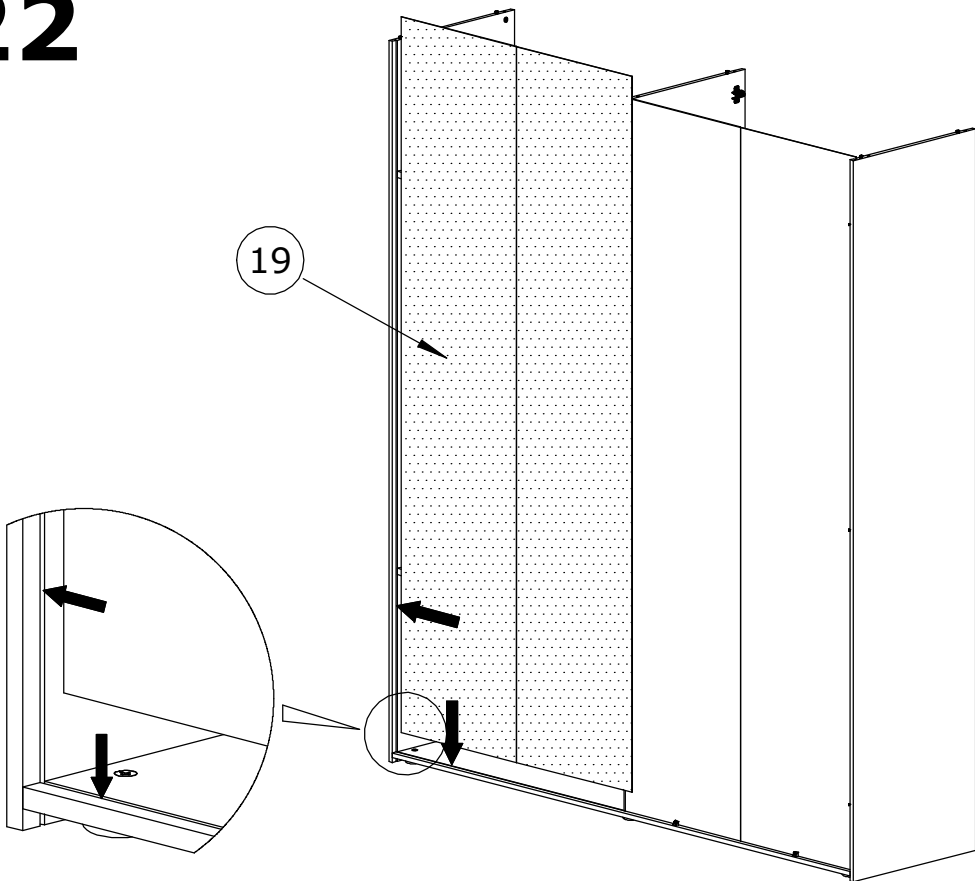

23

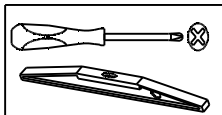

90°

K



5x

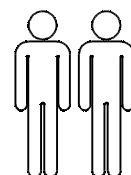
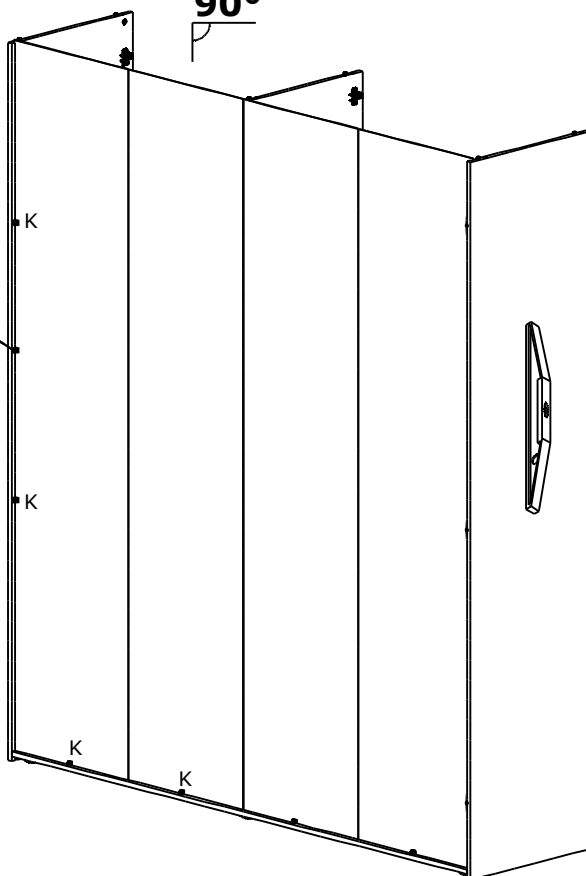
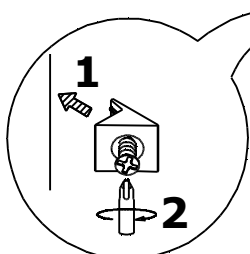

24

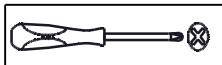

8

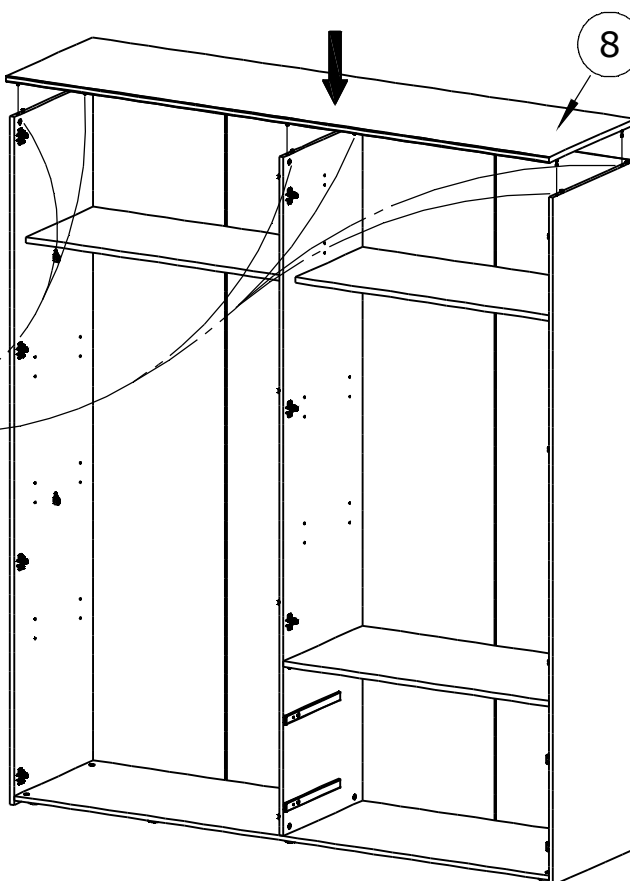
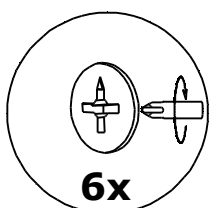
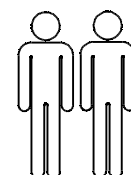

25

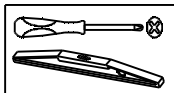

90°

NIVEAU

G
L=20 mm



6x

K



4x

Q

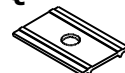

6x

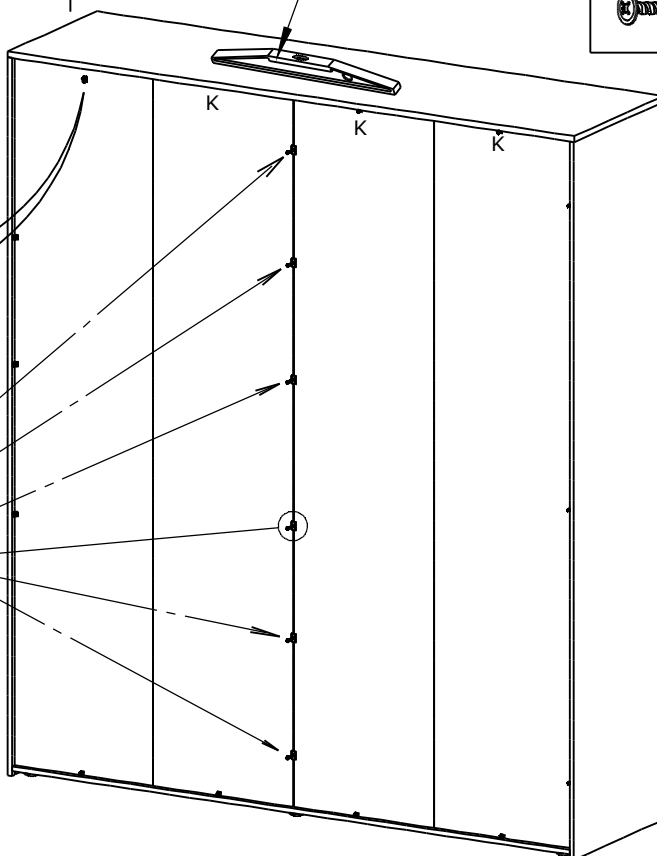
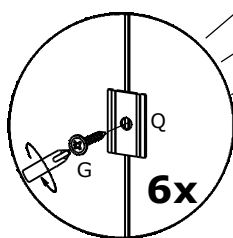
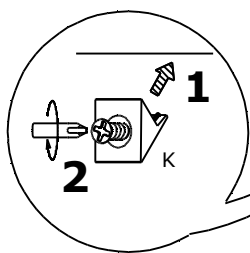

26

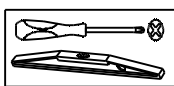

90°

G
L=20 mm



6x

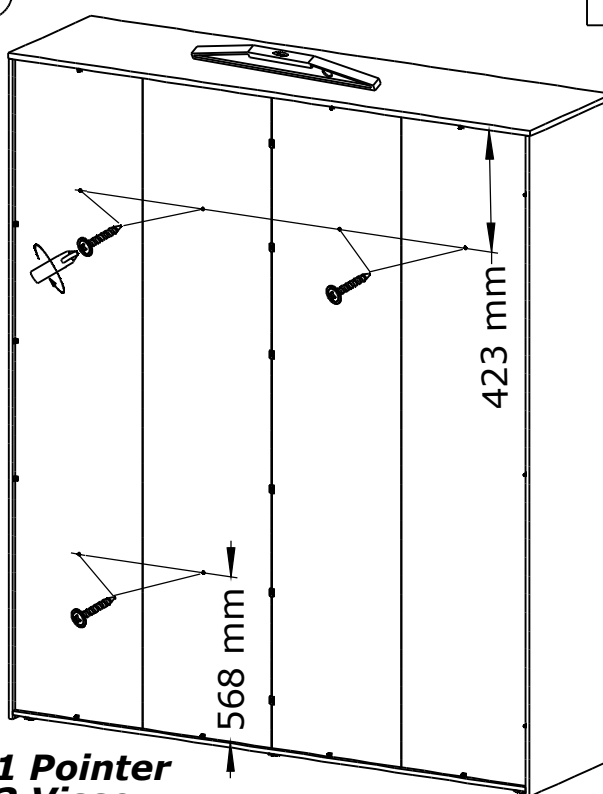
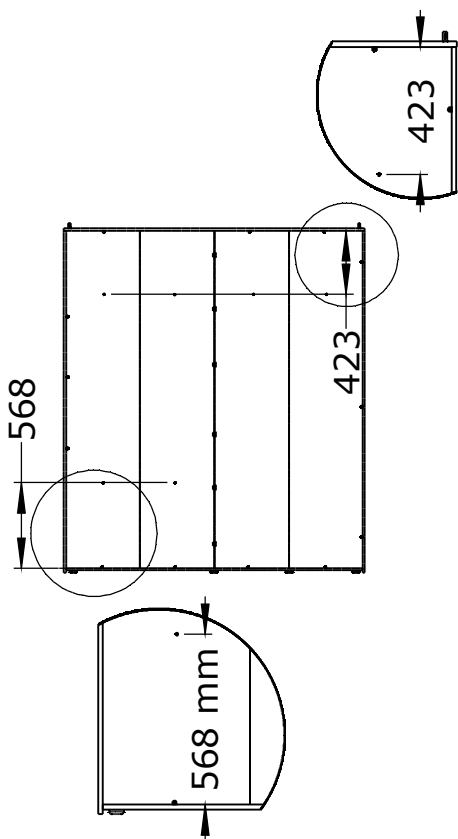

1 Pointer
2 Visser

27

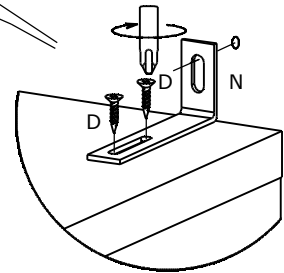
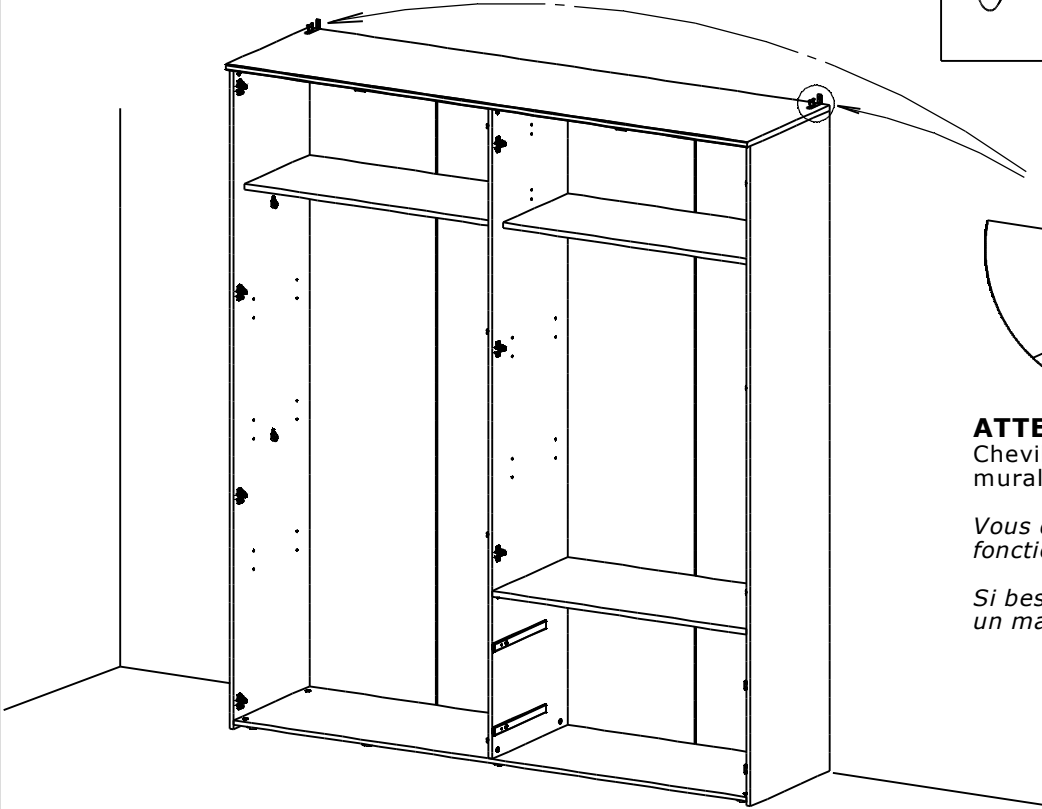
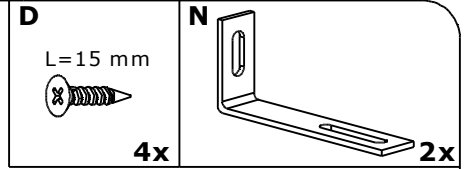
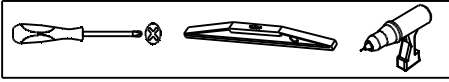

ATTENTION !
Chevilles et vis de fixation murales **NON FOURNIES**.
Vous devez les choisir en fonction de votre mur.
Si besoin adressez-vous à un magasin spécialisé.

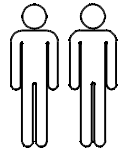

28

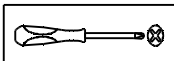

2x

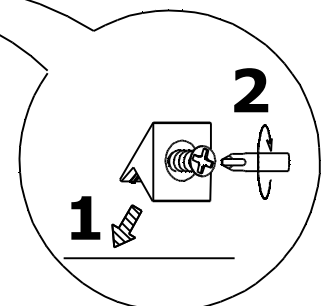
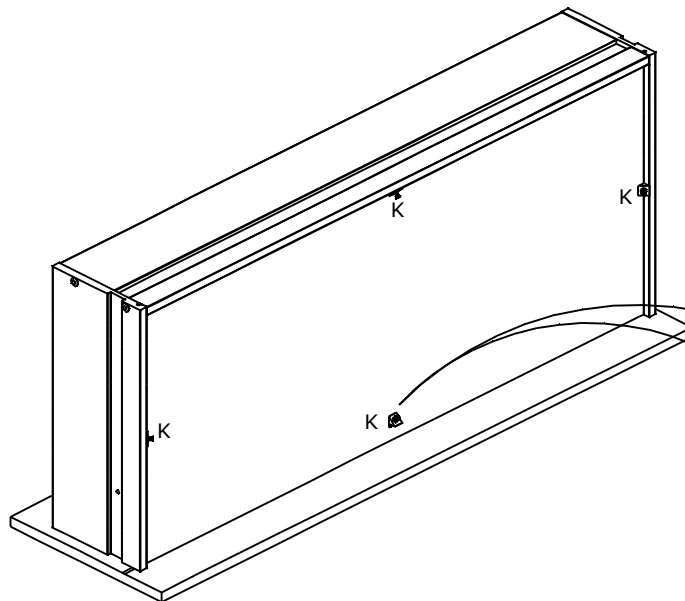
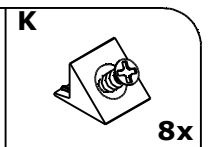

29

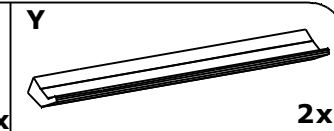
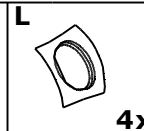
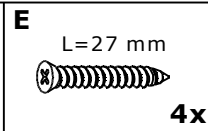
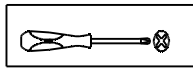

2x

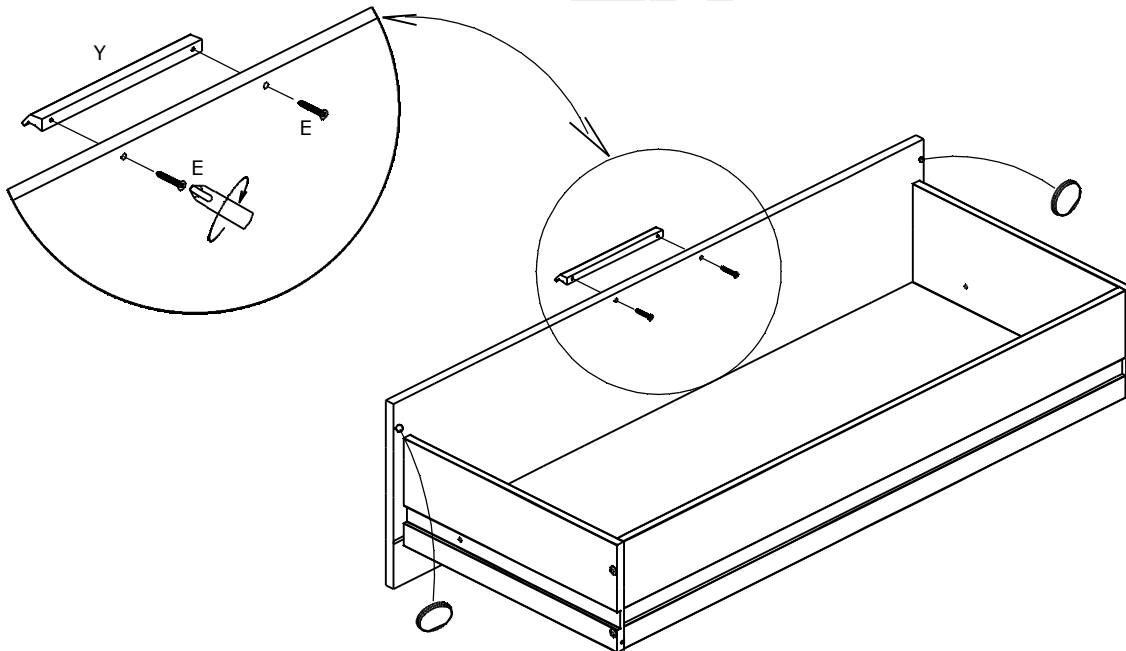

30

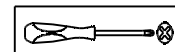
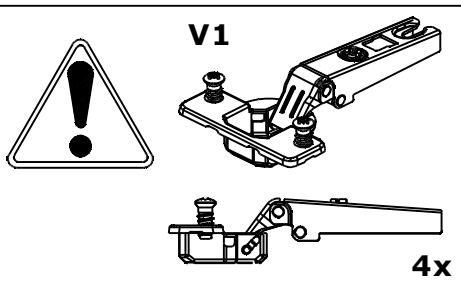

17 **Porte gauche**

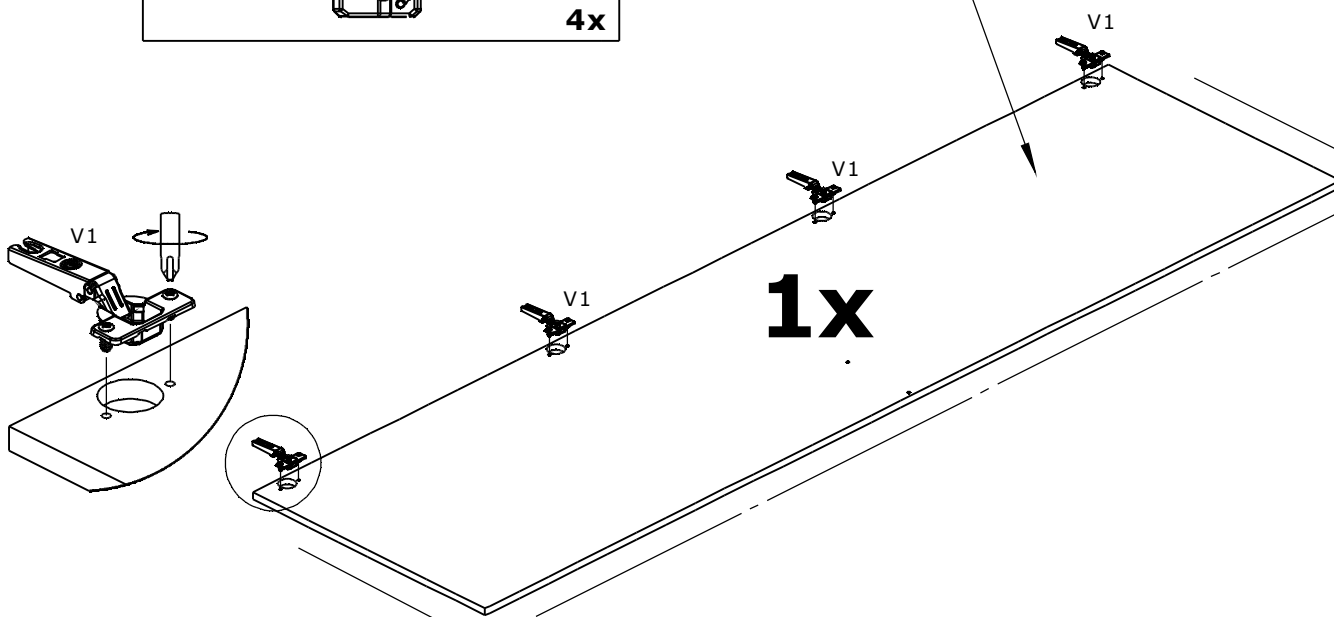

31

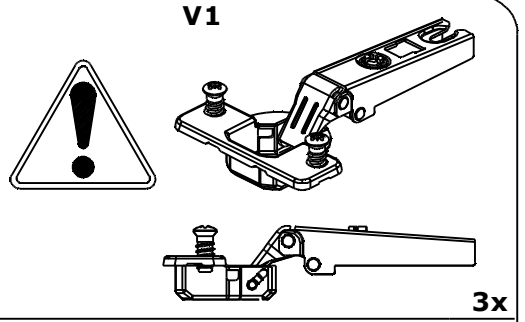
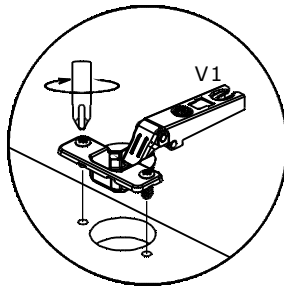
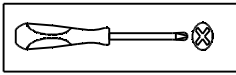

V1

3x

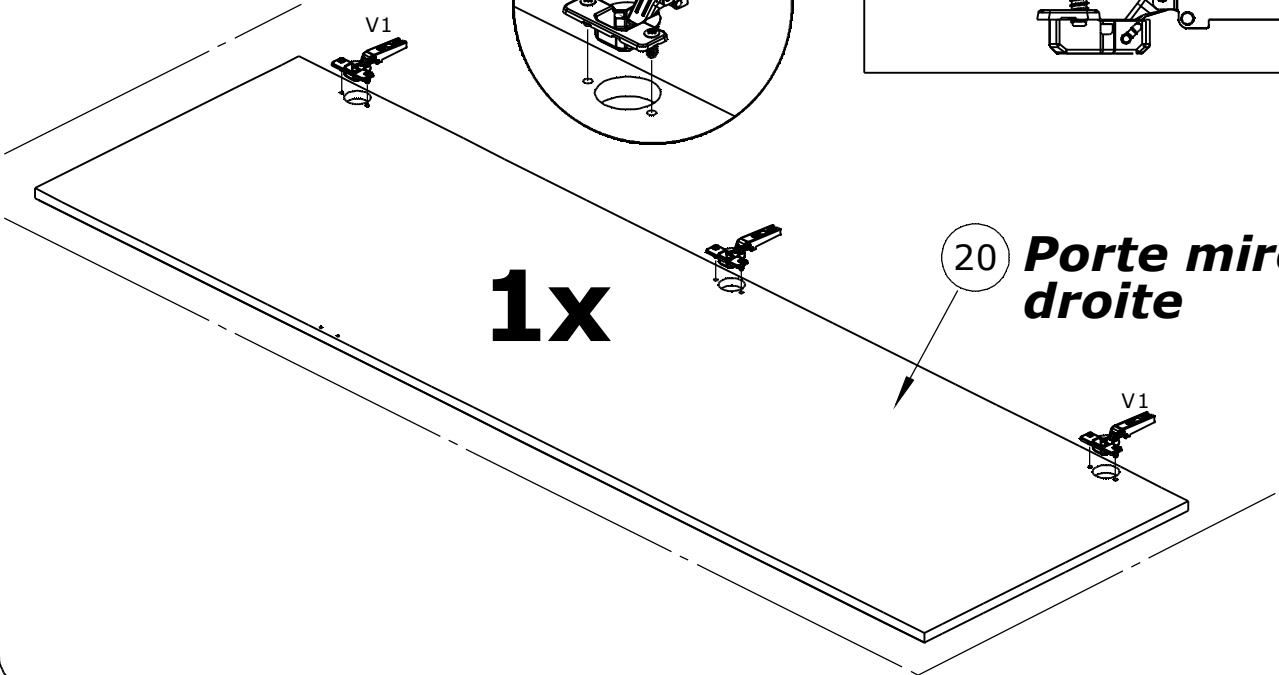

1x

20

Porte miroir droite

32

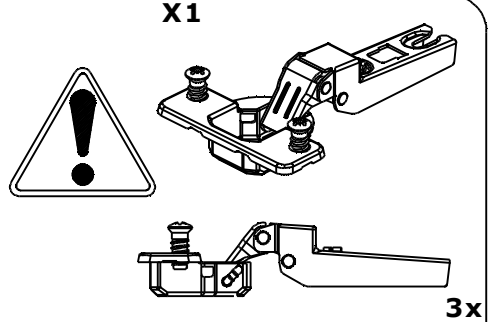
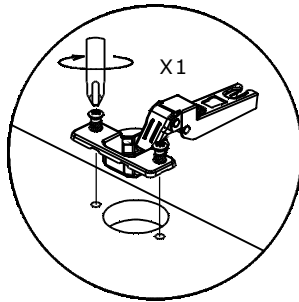
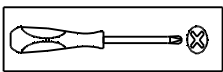

X1

3x

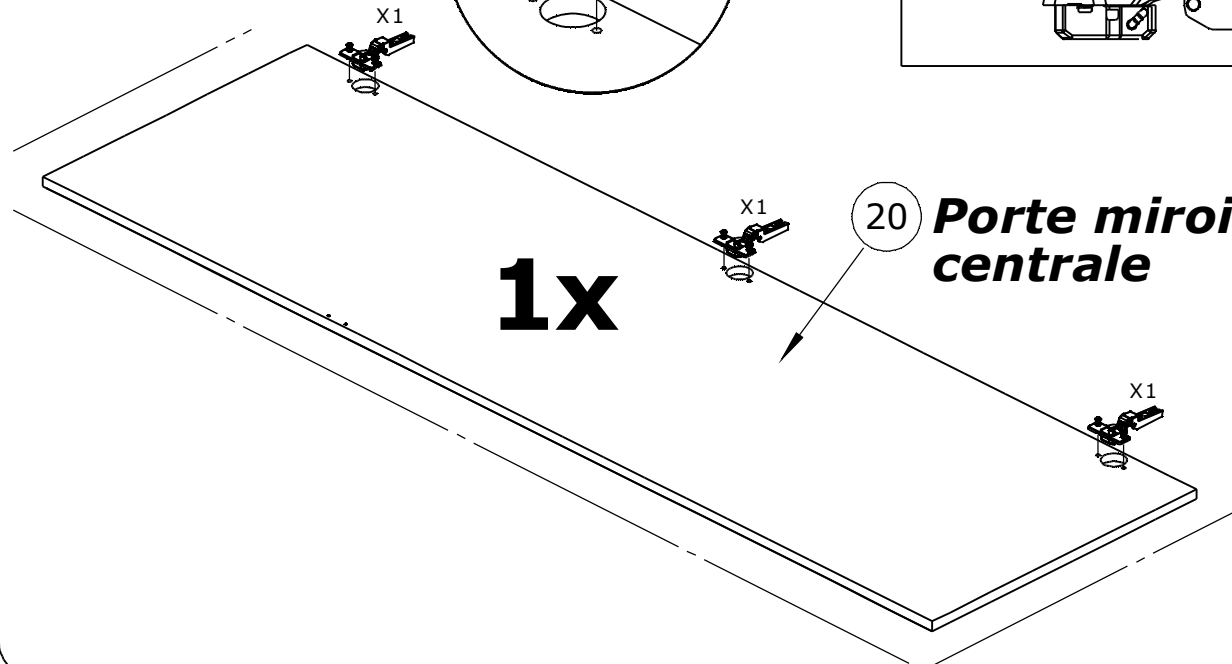

1x

20

Porte miroir centrale

33

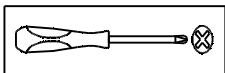

X1

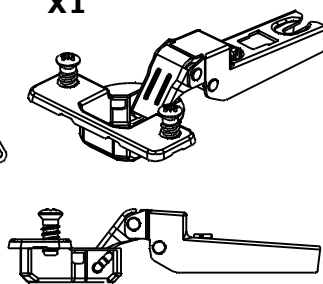

4x

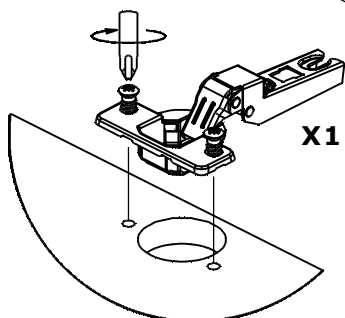
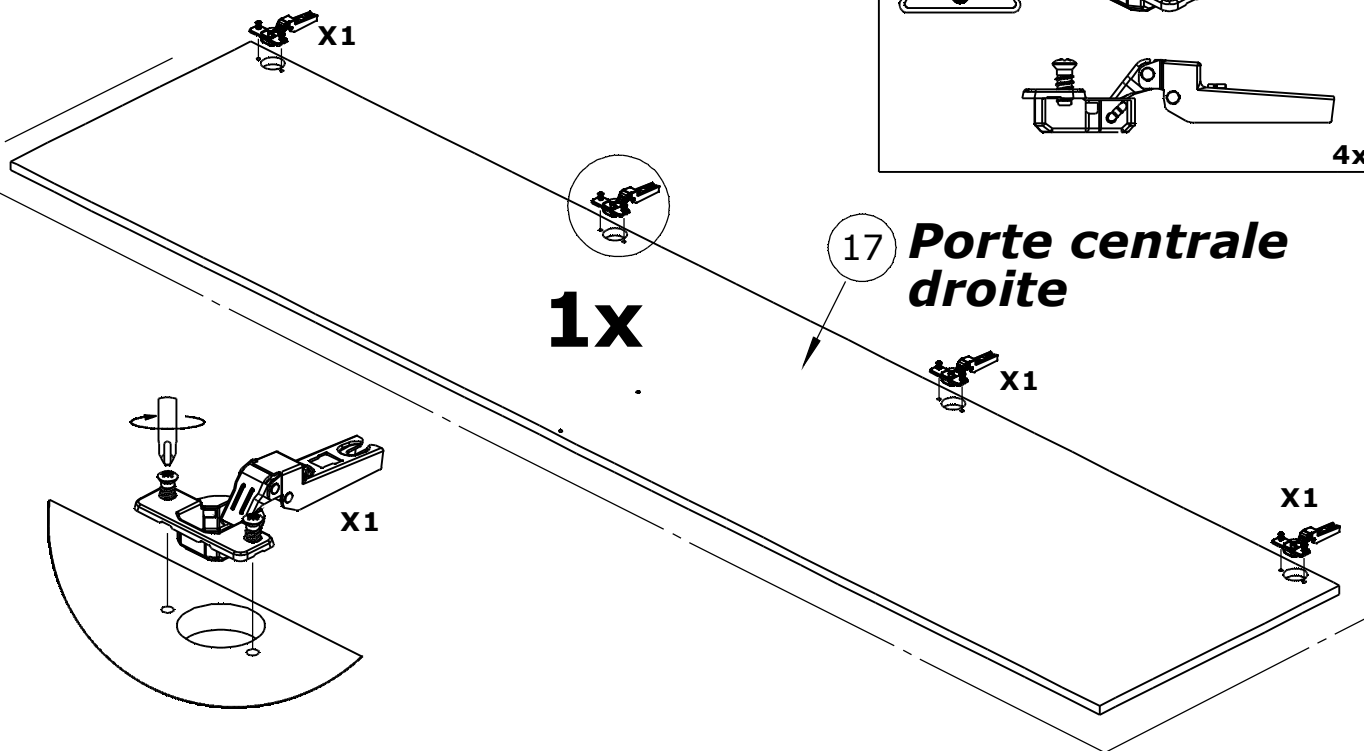

34

0



8x

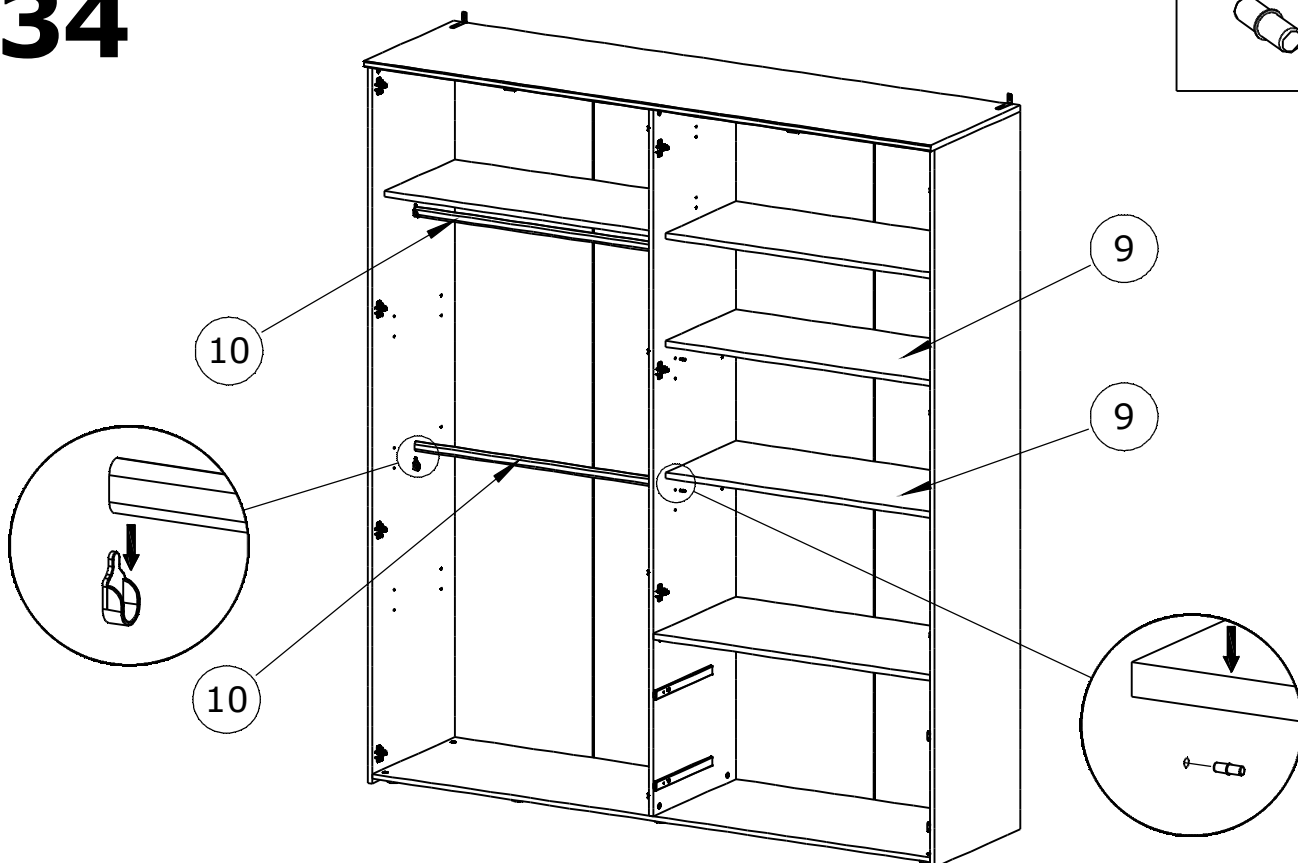

35

F
L=9 mm
4x

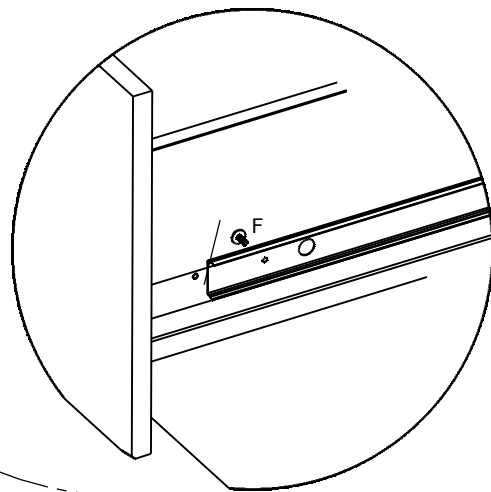
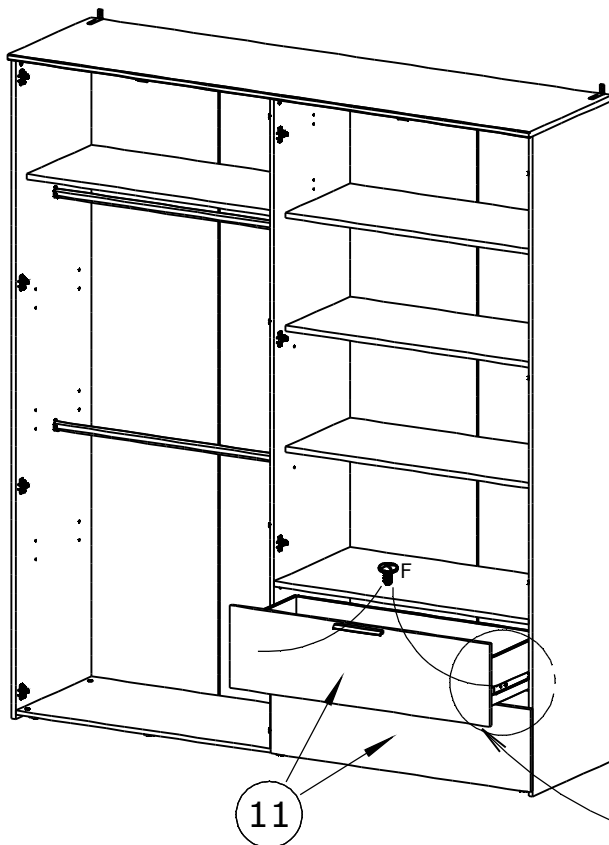

36

L
8x

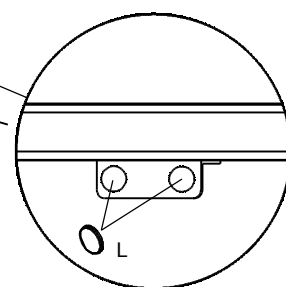
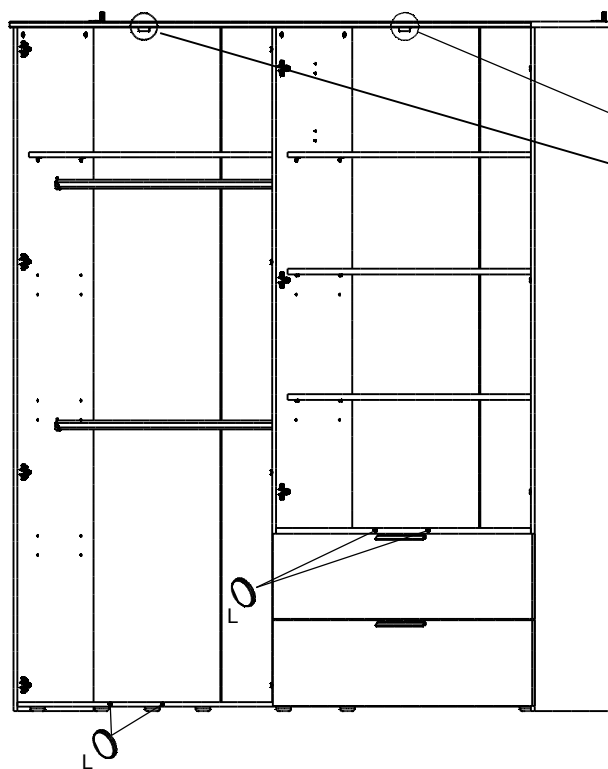

37

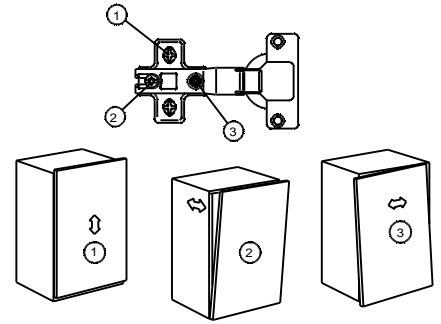
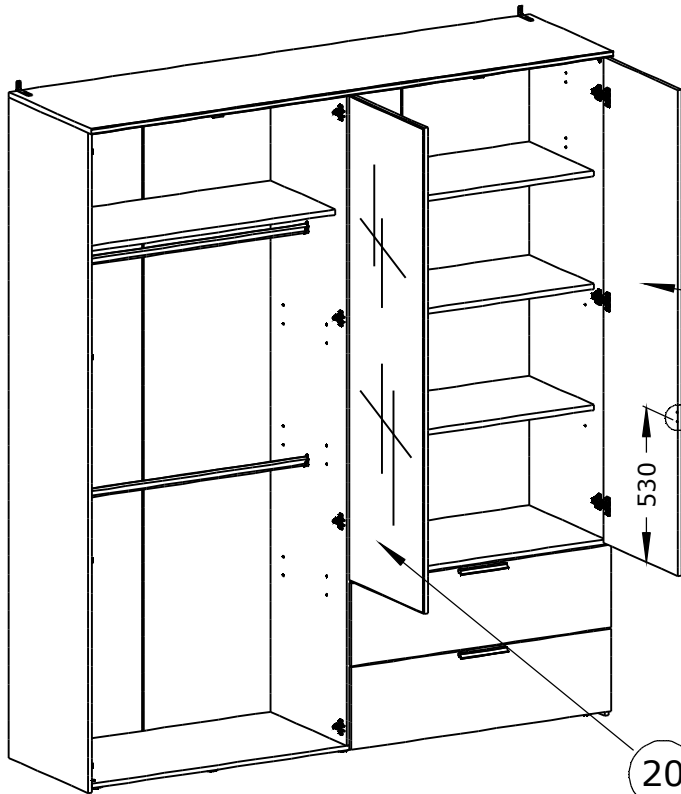
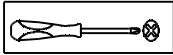

20 *Porte miroir droite*

20 *Porte miroir centrale*

38

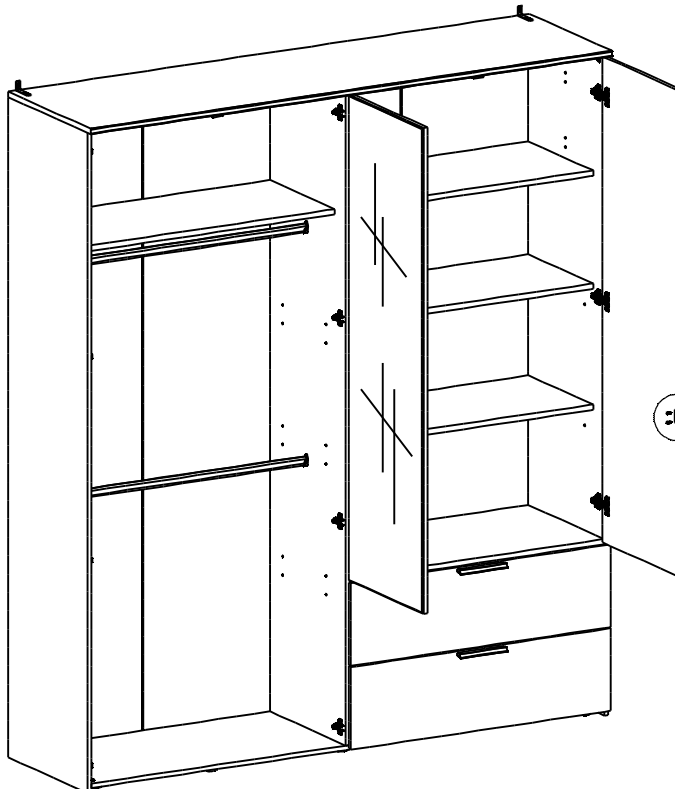
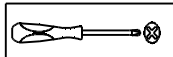

Z1

L=15 mm



2x

Z

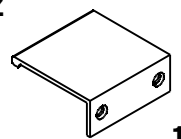

1x

39

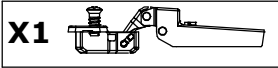
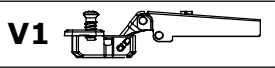
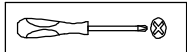

Porte gauche 17

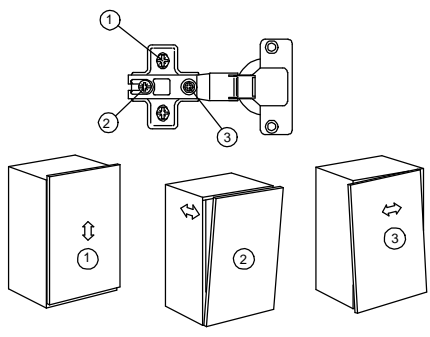
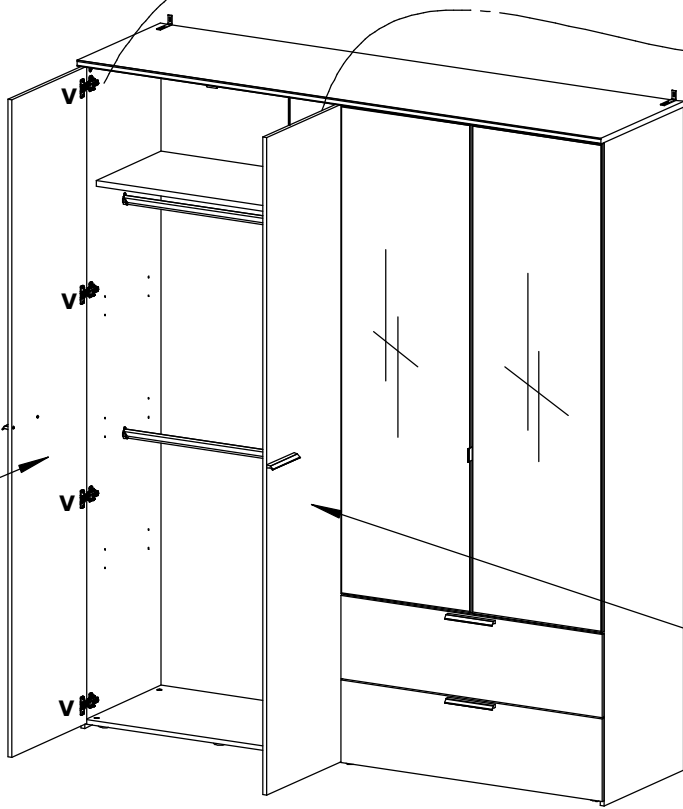

17 Porte centrale droite

40

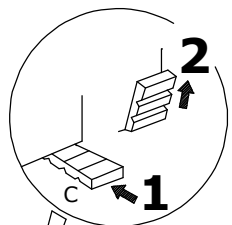
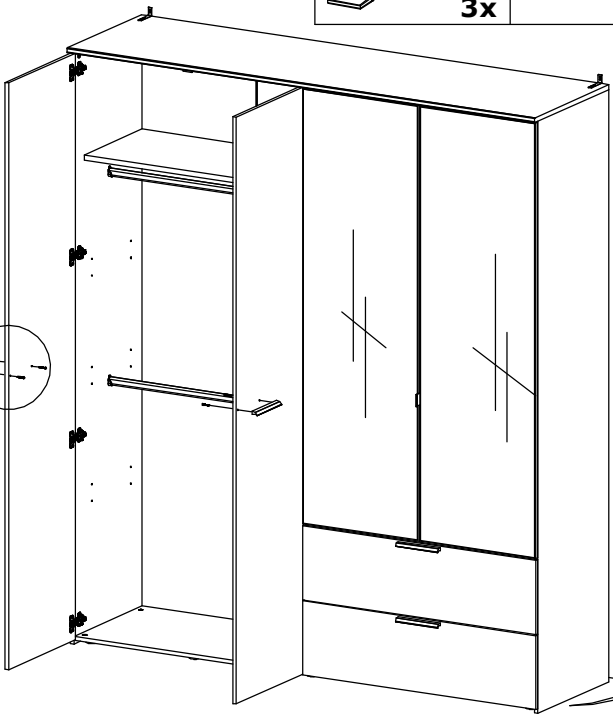
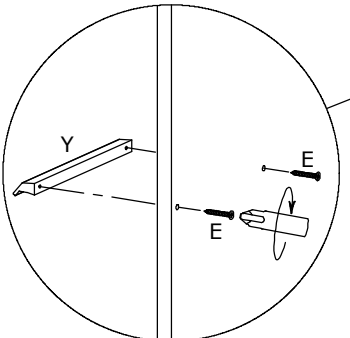
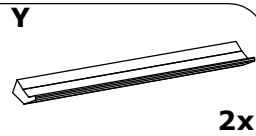
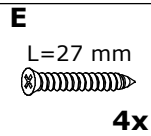
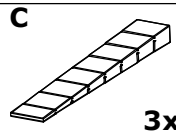
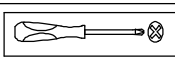

<p>PENSEZ AU TRI!</p>	<p>ENSEMBLE REDUISONS L'IMPACT ENVIRONNEMENTAL DES EMBALLAGES</p>	<p>ÉLÉMENTS BOIS PLASTIQUE</p> <p>A JETER</p>	<p>ÉLÉMENTS METAL CARTON PAPIER</p> <p>A RECYCLER</p>

CONSIGNE POUVANT VARIER LOCALEMENT > WWW.CONSIGNESDETRI.FR

F CONSEILS D'ENTRETIEN :

- 1) Dépoussiérez soigneusement.
- 2) Humectez un chiffon doux et propre, d'eau légèrement savonneuse.
Ne jamais utiliser de produits abrasifs : poudre, laine d'acier, solvants.
Ne pas mouiller copieusement.

**NE JAMAIS FORCER LES ASSEMBLAGES
RESSERRER LES VIS APRES QUELQUES TEMPS D'USAGE
GARDER VOTRE NOTICE DE MONTAGE, SI UNE PIECE
VENAIT A MANQUER, ELLE SERAIT LE PLUS CLAIR MOYEN
DE COMMUNIQUER AVEC VOTRE MAGASIN.**

**GB NOTICE FOR MAINTENANCE :**

- 1) Dust off carefully.
- 2) Use a soft, proper and humid duster and light soap solution to clean the furniture.
Please do not use any scouring agent like powder, steel wool, solvents.
Do not wet too much.

**NEVER FORCE THE CONNECTIONS
RE-TIGHTEN THE SCREWS AFTER FEW DAYS.
PLEASE RETAIN THE AI LEAFLET FOR FUTURE REFERENCE,
THE AI CONTAINS INFORMATION WHEN CLAIMING
FOR MISSING PARTS.**

**D PFLEGEHINWEISE :**

- 1) Sorgfältig entstauben.
- 2) Mit einem weichen, sauberen und feuchten Tuch und leichter Seifenlauge reinigen.
Benutzen Sie keine Scheuermittel wie Pulver, Stahlwolle, Lösungsmittel.
Nicht zu nass abwischen.

**NIEMALS DIE VERBINDUNGEN ZU STARCK ANZIEHEN
DIE SCHRAUBEN NACH EINIGER ZEIT DES GEBRAUCHS
ERNEUT FESTZIEHEN. DIE MONTAGEANLEITUNG GUT
AUFBEWAHREN, SOLLTE EIN TEIL FEHLEN, IST SIE DAS
BESTE VERSTÄNDIGUNGSMITTEL MIT IHREM GESCHÄFT.**

**I CONSIGLI PER LA MANUTENZIONE :**

- 1) Spolverate accuratamente.
- 2) Inumidire con acqua leggermente insaponata uno straccio morbido e pulito.
Non utilizzare mai prodotti abrasivi : polvere, lana di acciaio, solventi.
Non bagnare troppo.

**NON FORZARE MAI GLI ASSEMBLAGGI
RISTRINGERE LE VITI DOPO UN PERIODO D'USO
CONSERVARE QUESTE ISTRUZIONI DI MONTAGGIO, SE
UN PEZZO VENISSE A MANCARE SAREBBE IL MIGLIORE
MEZZO DI COMUNICAZIONE CON IL RIVENDITORE.**

**E RECOMENDACIONES PARA EL MANTENIMIENTO :**

- 1) Despolvorear cuidadosamente.
- 2) Humedecer un pano suave y limpio con agua ligeramente enjabonada.
No use nunca productos abrasivos tales como : polvo de limpiar, lana de acero, solventes.
No mojar exageradamente.

**NO FUERCE NUNCA EN LAS UNIONES . APRIETE LOS
TORNILLOS DESPUES DE CIERTO TIEMPO DE UTILIZACION
CONSERVE SU MANUAL DE MONTAJE, SI FALTARA UNA
PIEZA, SERIA LA MANERA MAS FACIL DE COMUNICAR
CON LA TIENDA.**

**P NORMAS DE MANUTENCAO :**

- 1) Eliminar bem o po.
- 2) Umedecer um pano suave e limpo com agua e um pouco de sabao.
Nunca utilizar produtos abrasivos : pos, la de aço, solventes.
Nao molhar demasiado.

**NUNCA FORCAR OS ENCAIXES.REAPERTAR OS
PARAFUSOS APOS UM TEMPO DE UTILIZACAO.
GUARDAR AS INSTRUCOES DE MONTAGEM.
CASO FALTE ALGUMA PECA , O MAIS A CONSELHABEL
E CONTATAR O REVENDEDOR.**

**TR BAKIM TALIMATLARI :**

- 1) Tozunu dikkatlice aliniz.
- 2) Yumusak bir bezi temiz su ve az miktarda sabunla (deterjan) nemiendiriniz
- Asla asindirici ürünler kullanmayiniz : Celik yünü, solvent
- Bol suyla yikamayiniz.

**MONTAJLARI ZORLAMAYINIZ.
BIRKAC KULLANIMDAN SONRA VIDALARI SIKISTIRINIZ.
BIR PARCANIN KAYBOLMASI DURUMUNDA MAGAZANIZ-
LADAH KOLAY ILETISIME GECEBILMENIZ ICIN MONTAJ
KULLANIM TALIMATINIZI SAKLAYINIZ.**

**HR UPUTE ZA ODRZAVANJE :**

- 1) Pazljivo obrisati prasinu.
- 2) Koristite suhu krpu.
- Zabranjena je upotreba kemikalija ili bilo kakvih pomocnih sredstava za ribanje jakih sredstava za ciscenje ili celigne vune
- Ne mokra.

**NEMOJTE UPOTREBLJAVATI SILU PRILIKOM SKLAPANJA
NAKON NEKOG VREMENA PONOVRNO PRITEGNITE VIJKE
CUVAJTE UPUTE ZA MONTAZU
U SLUCAJU NEDOSTATKA NEKOG DIJELA NAJBOJE CE BITI
DA KONTAKIRATE PRODAJNO MJESTO.**

**NL VEILIGHEIDS MAATREGELEN**

- 1) Poets voorzichtig.
- 2) Nooit poetsen met veel water of met schurende producten. Gebruik alleen een klamvochtige doek.

**LET OP ! NOOIT PROBEREN TE FORCEREN TIJDENS
DE MONTAGE VAN UW MEUBILAIR. MOCHT ER IETS
ONTBREKEN NEEM DAN DE MONTAGEHANDLEIDING
MEE NAAR UW VERKOOPPUNT.**

