

**NOTICE DE MONTAGE
ASSEMBLING INSTRUCTIONS
MONTAGEANLEITUNG
ISTRUZIONI DI MONTAGGIO
INSTRUCOES DE MONTAJE
INSTRUCCIONES DE MONTAJE
UPUTE ZA MONTAZU
MONTAJ TALIMATI
MONTAGE-INSTRUCTIES**



**Commode 4 tiroirs
Commode met 4 laden
Kommode mit 4 Schubladen**

Réf. 523973

Décor imitation chêne clair
Licht eiken
Nachbildung Eiche hell

Réf. 523976

Décor imitation chêne nature
Naturel eiken
Nachbildung Eiche natur

Réf. 523974

Décor imitation chêne argile
Grijsst eiken
Nachbildung Eiche lehm

Réf. 523978

Décor imitation noyer brun
Bruin notenhout
Nachbildung Nussbaum dunkel





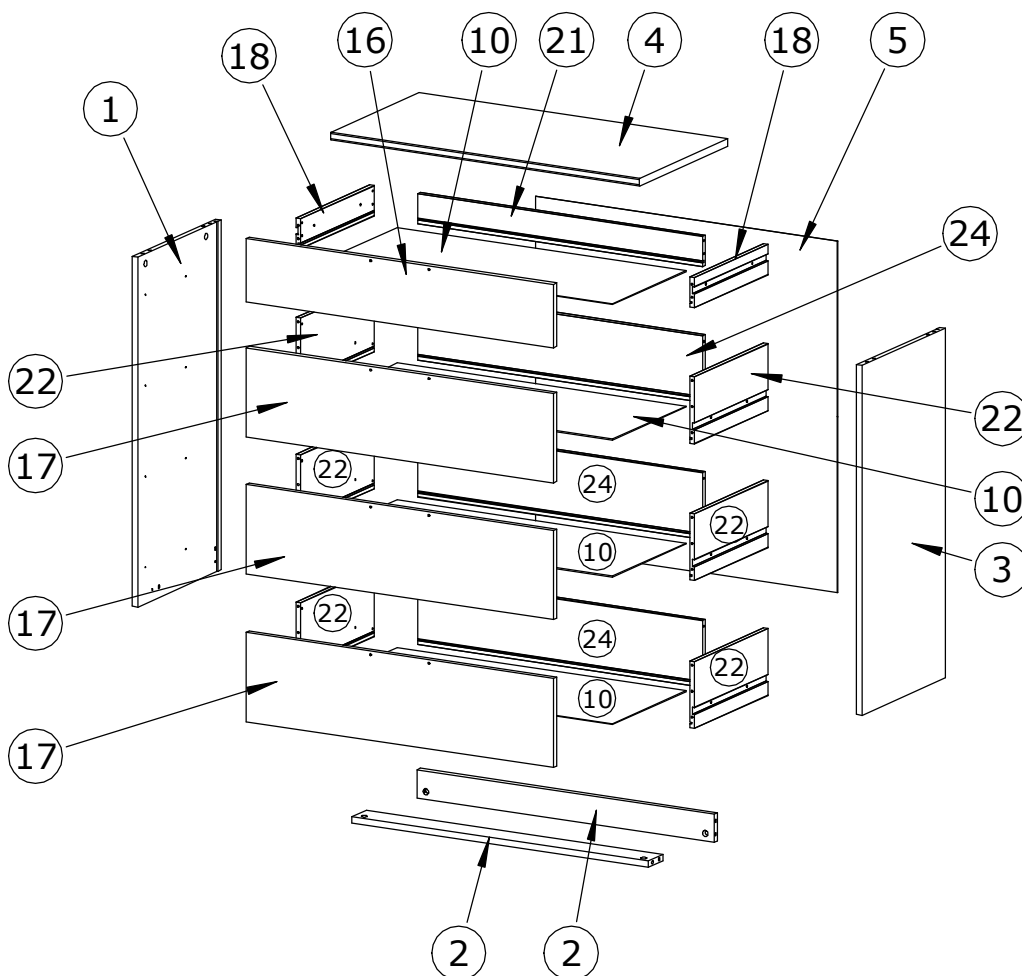
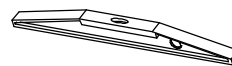
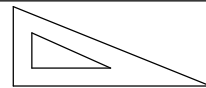
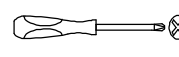
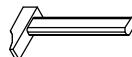
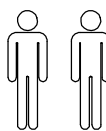



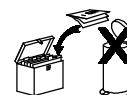

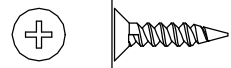
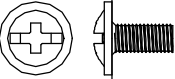
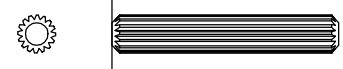
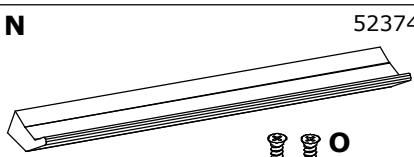

1:00

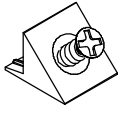

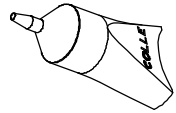
N°	Dimensions Afmetingen Massen
1	862x397x15 mm
2	816x70x15 mm
3	862x397x15 mm
4	848x420x19 mm
5	829x866x2,5 mm
16	844x156x15 mm
17	844x220x15 mm
18	351x75x12 mm
10	794x350x2,5 mm
21	783x75x12 mm
22	351x165x12 mm
24	783x165x12 mm

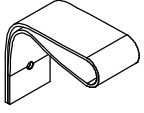
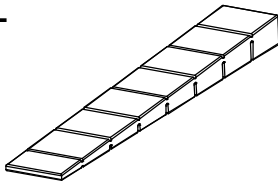

<p>A  8 x $\varnothing 8 \times 30$ mm (12920)</p> <p>B  8 x (504029)</p> <p>C  19 x $\varnothing 3,5 \times 15$ mm (31602)</p> <p>D  8 x M4x9 mm (38646)</p> <p>P  38 x $\varnothing 5 \times 30$ mm (12928)</p>	<p>N  523748</p> <p>O  4x</p>	<p>F 500617  8x</p> <p>G 52259  22x</p> <p>H 28403  8x</p> <p>I 52563  4x</p> <p>J 416664  4x</p> <p>K 430654  1x</p>
<p>L  35838 2x</p>	<p>M  52140 4x 2 pièces</p>	

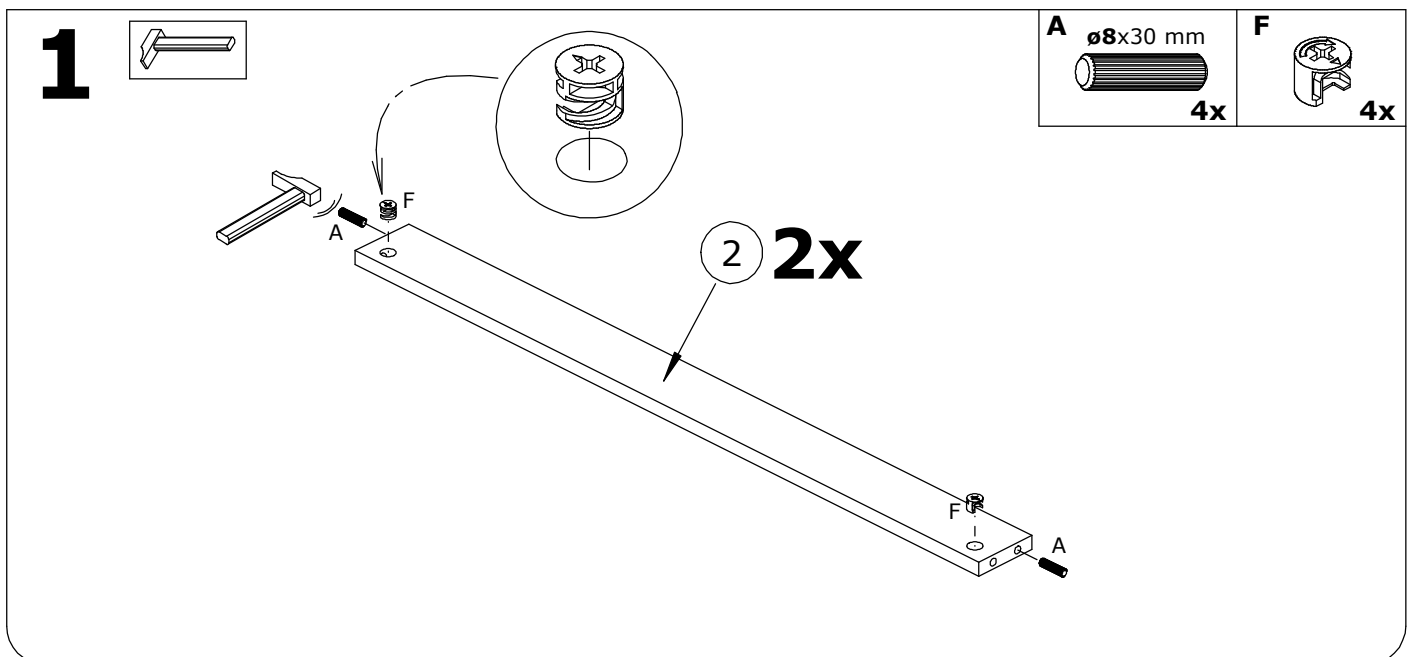

2

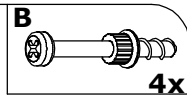
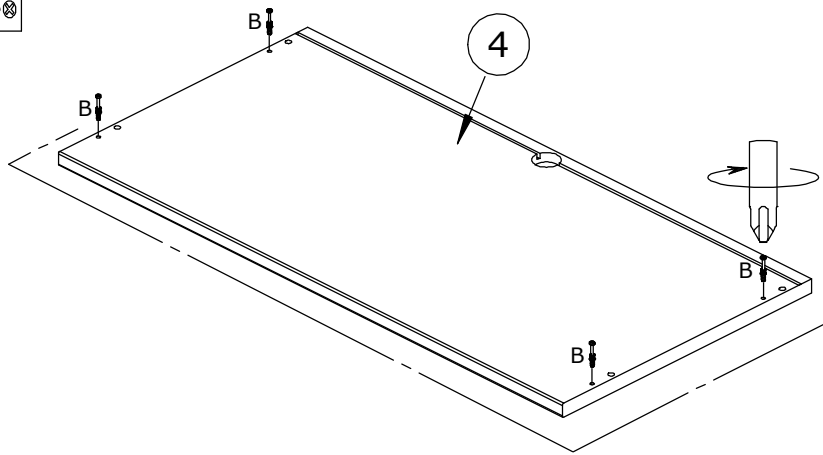
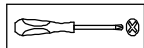

3a

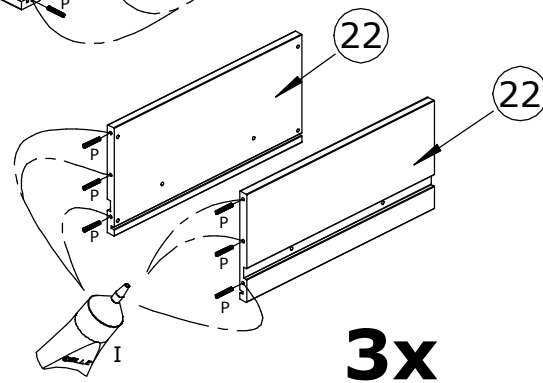
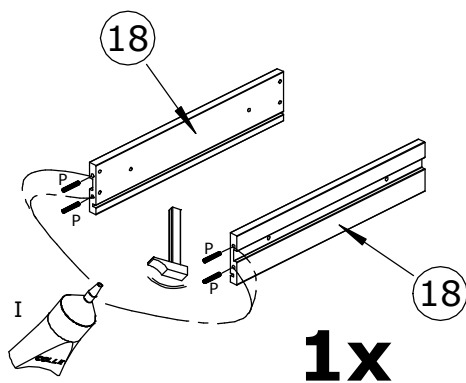
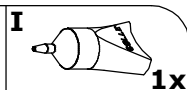
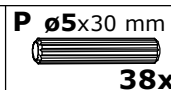
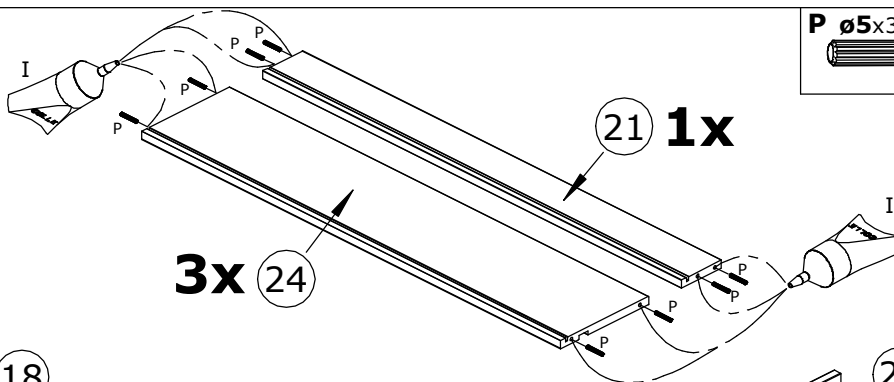
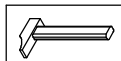

3b

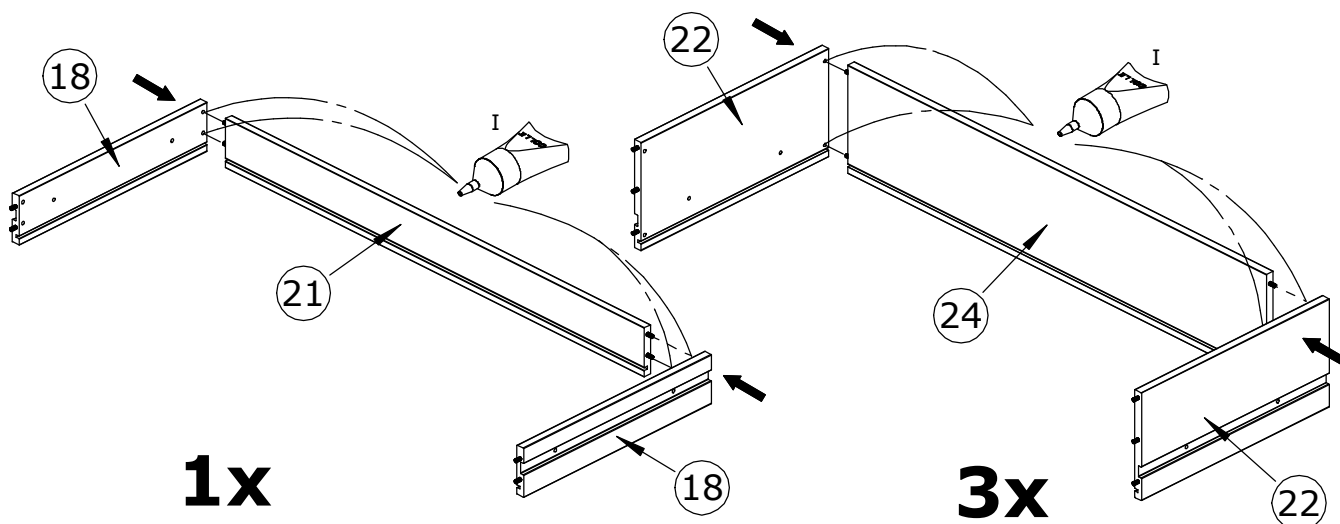
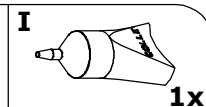

3c

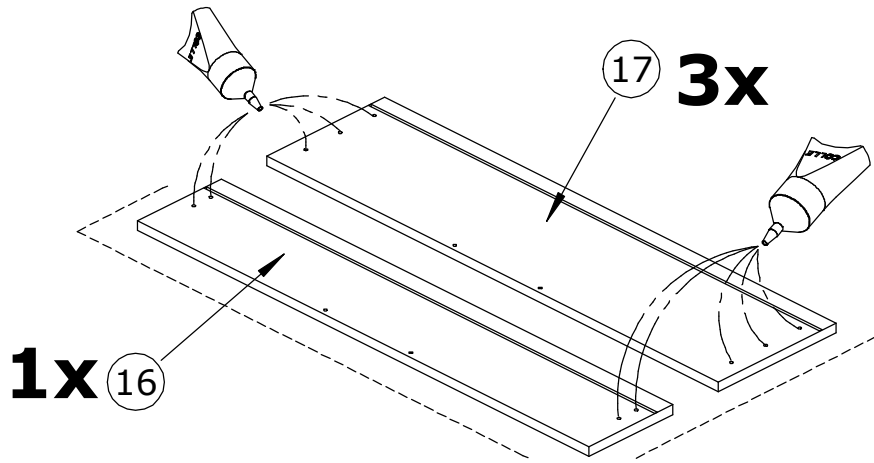

3d

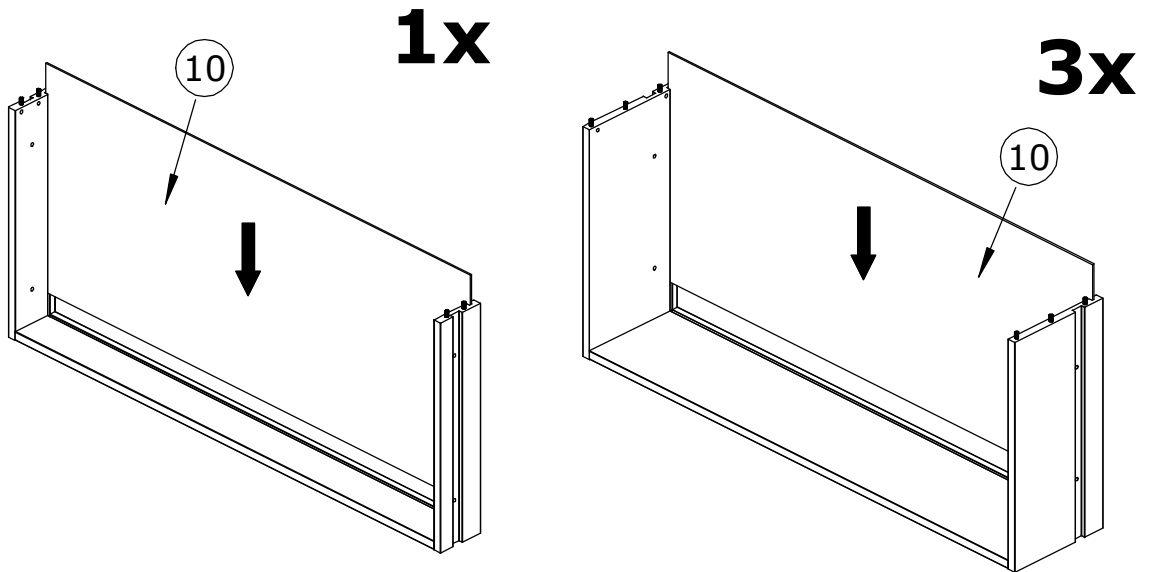

3e

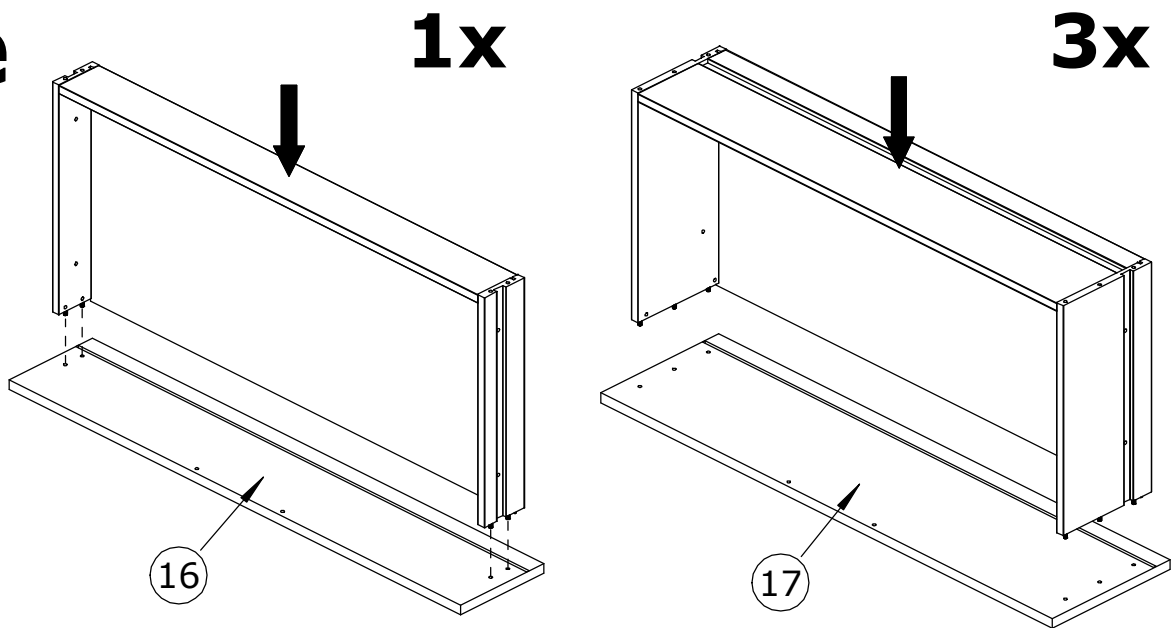

4

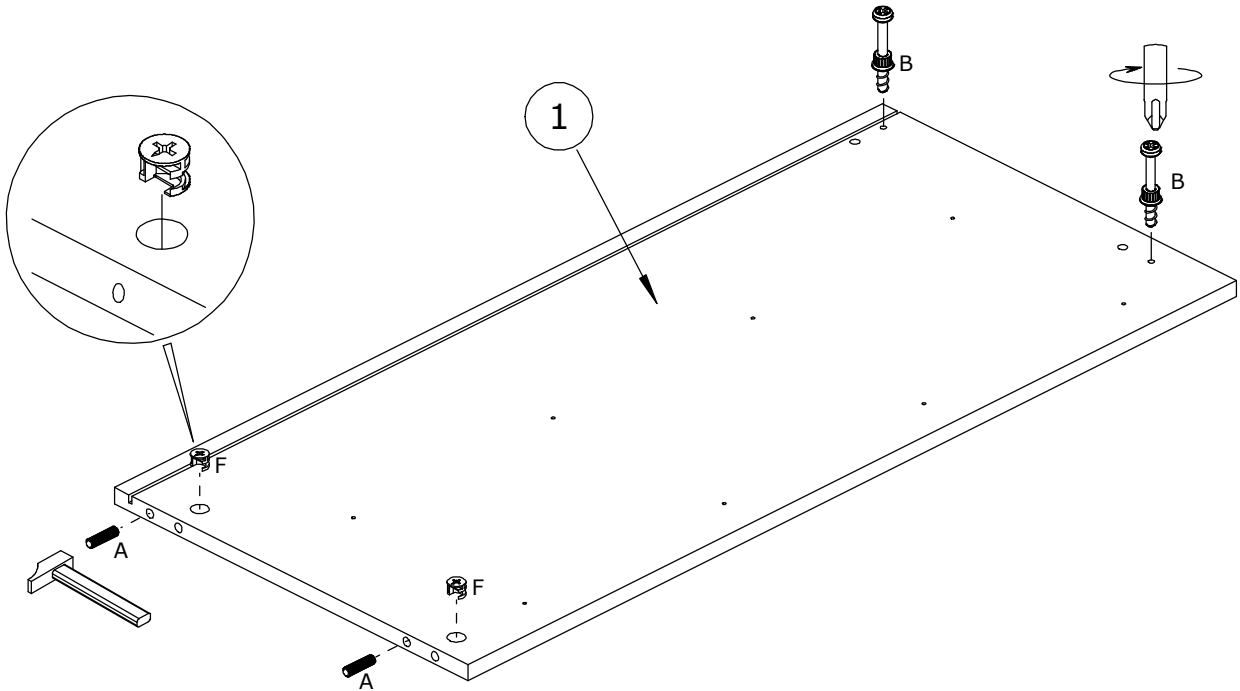
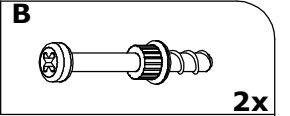
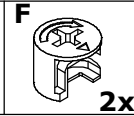
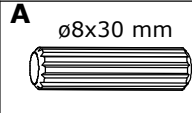
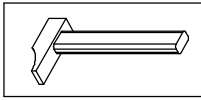

5

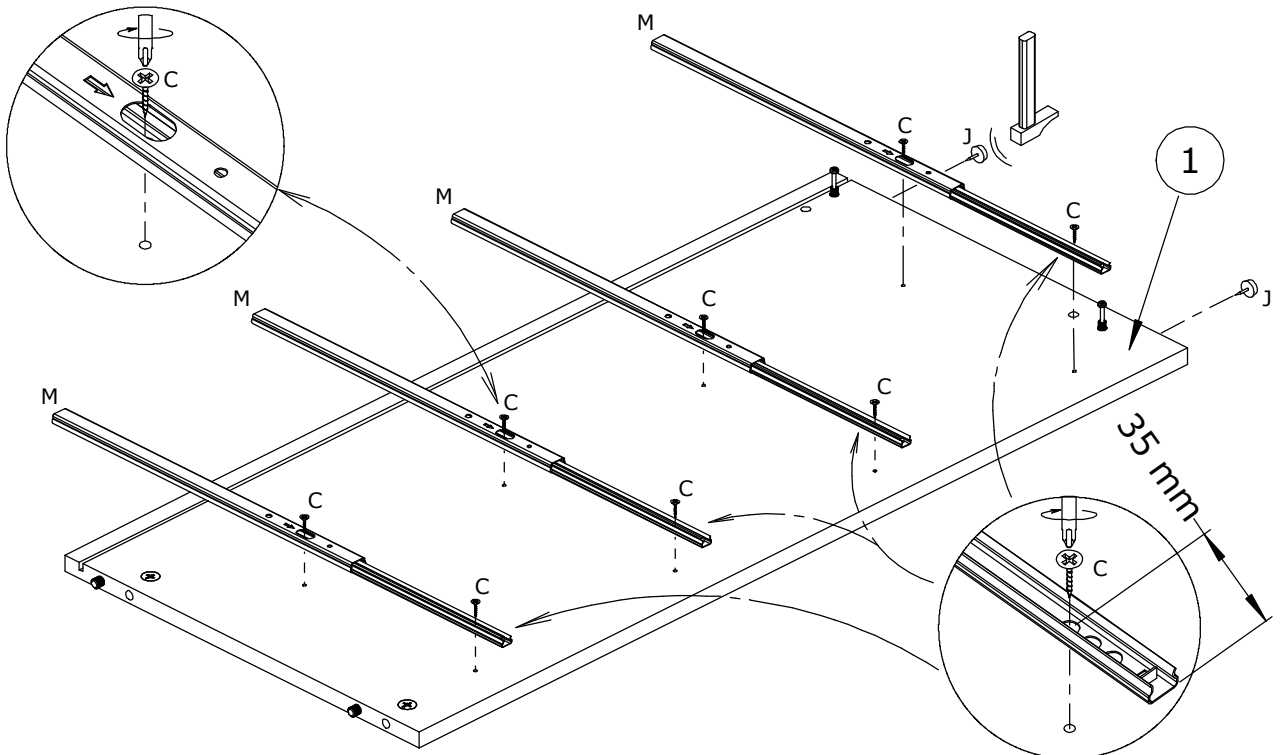
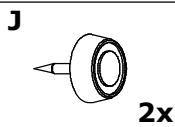
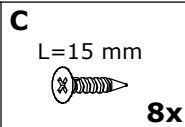
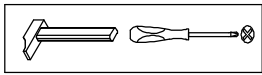

6

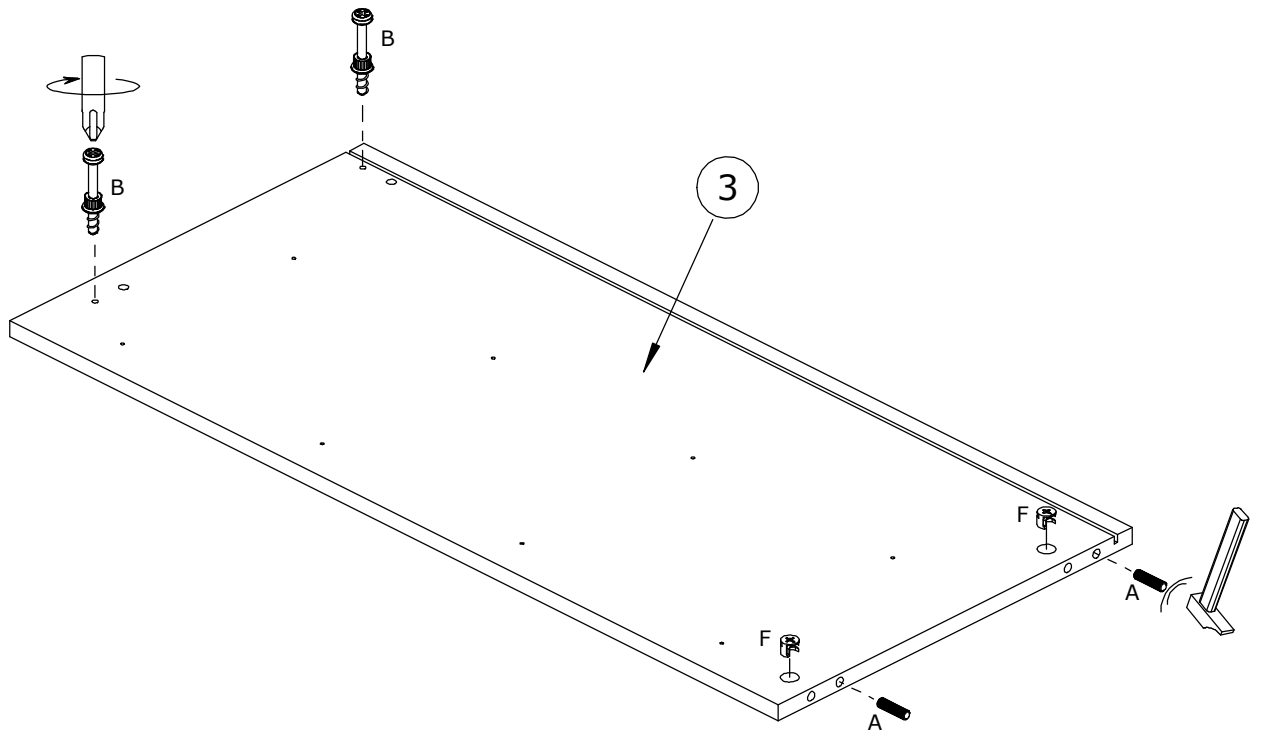
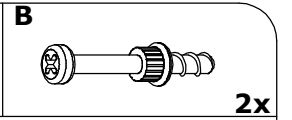
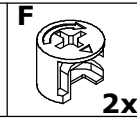
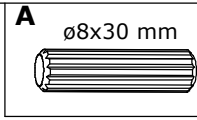
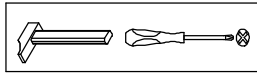

7

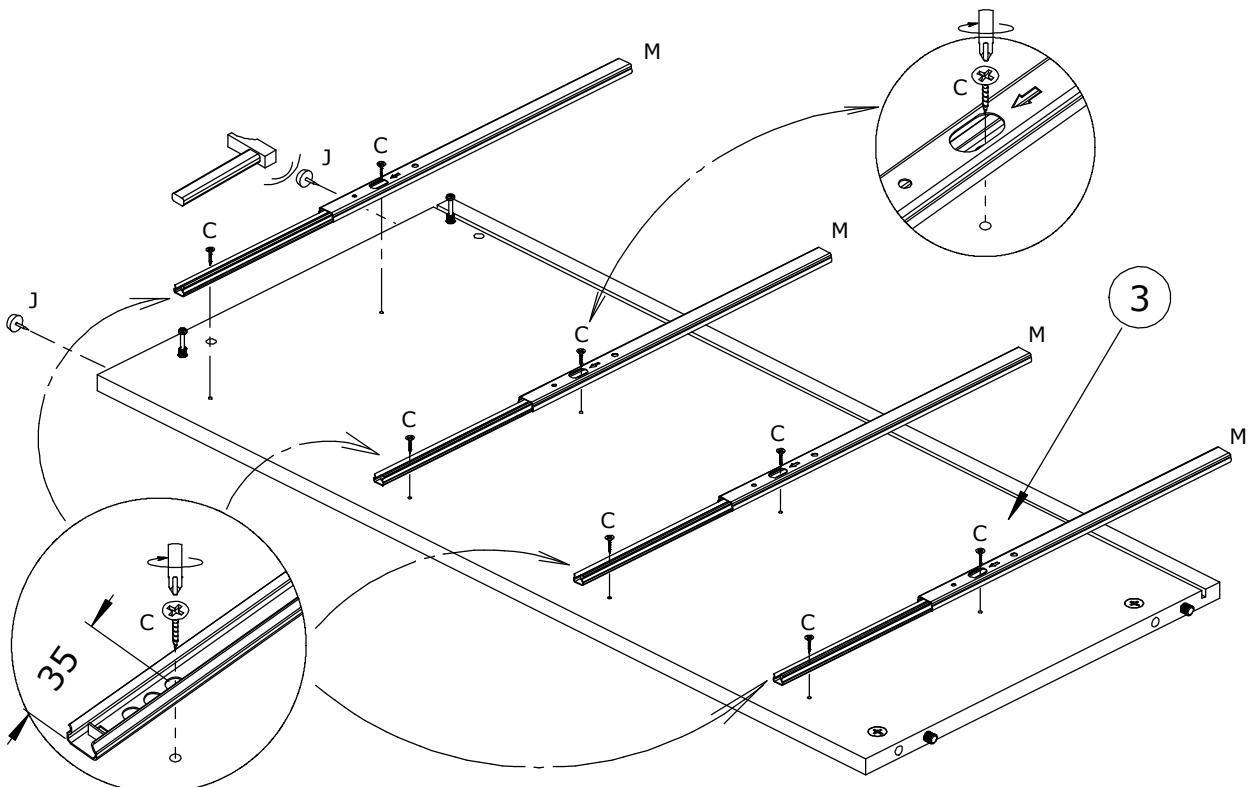
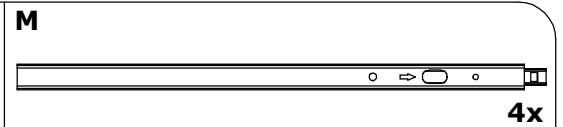
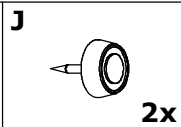
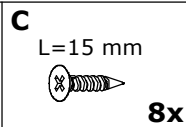
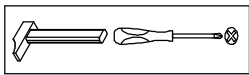

8

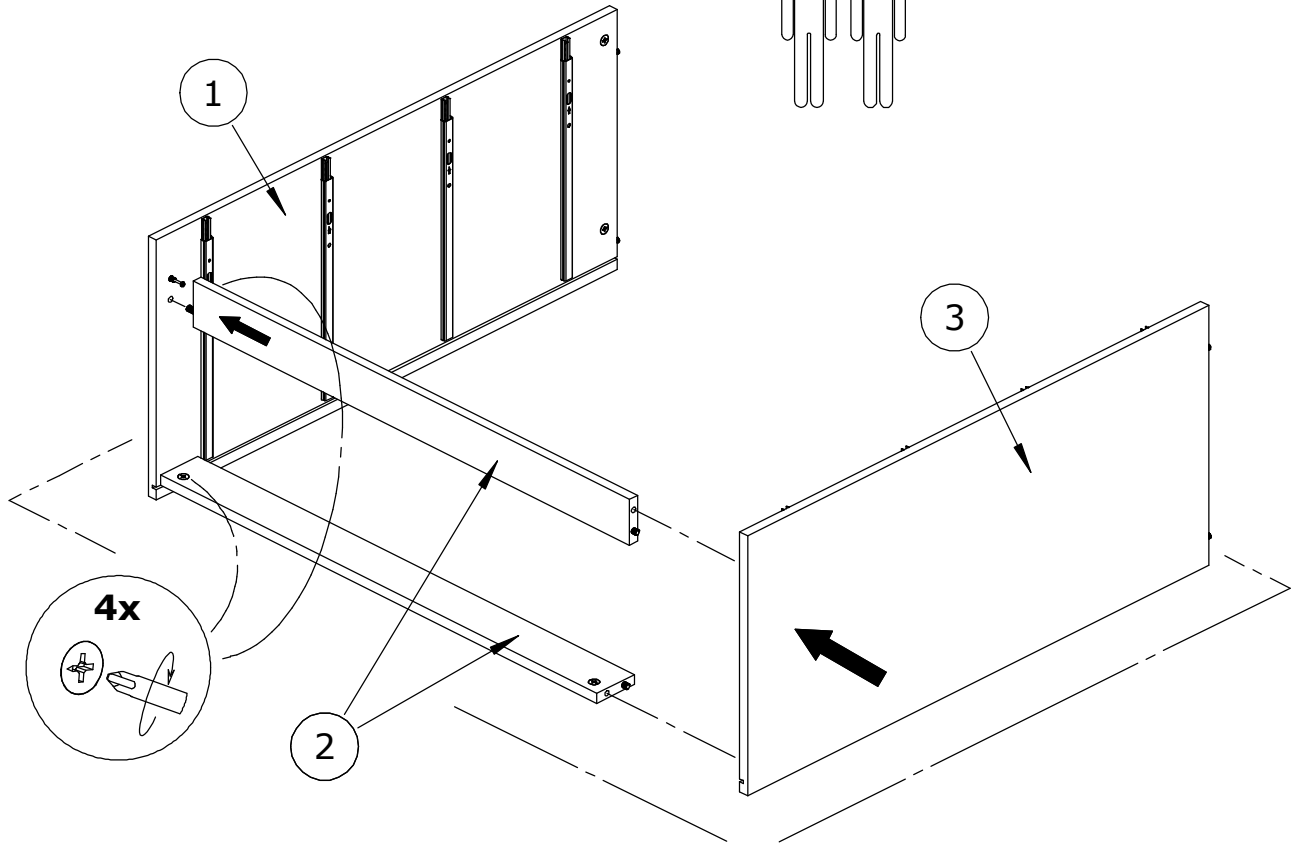
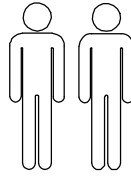
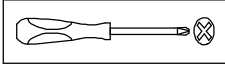

9

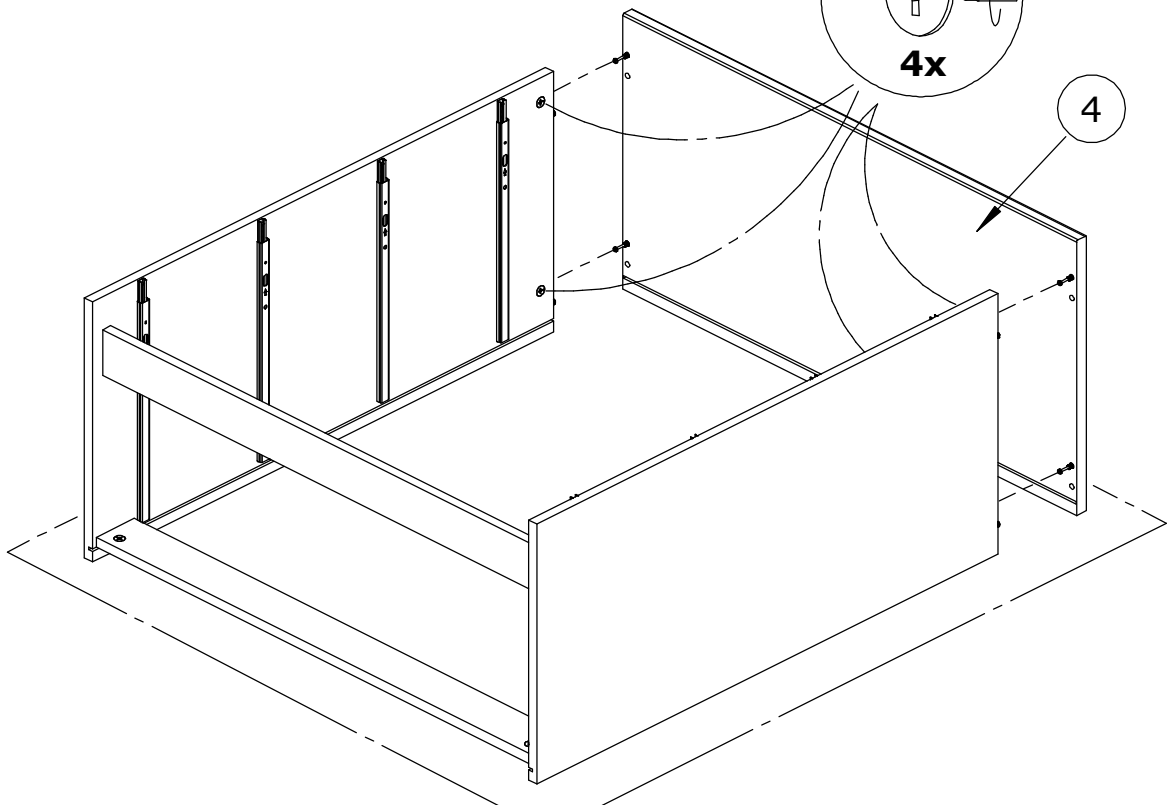
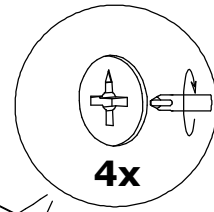
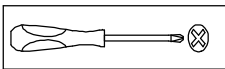

10

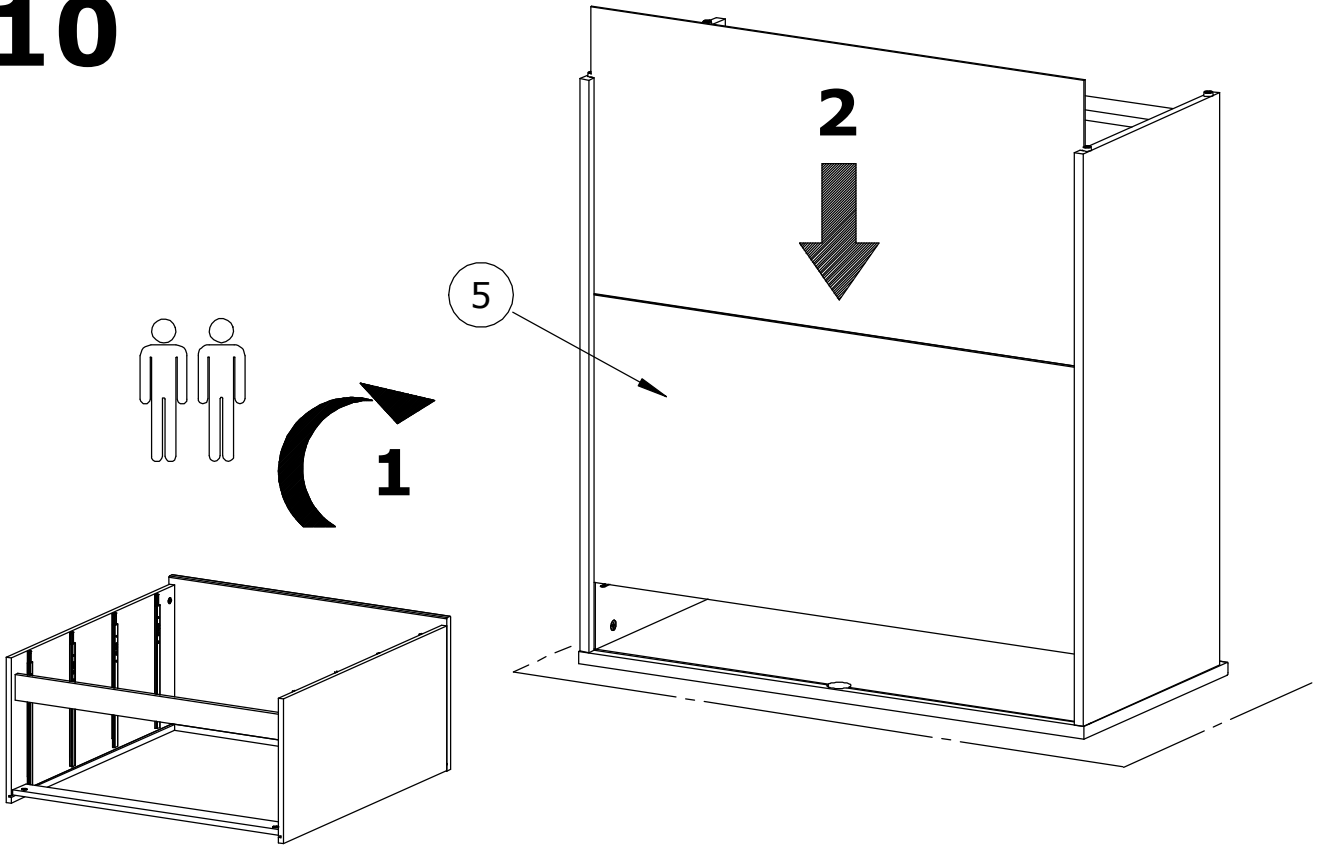

11

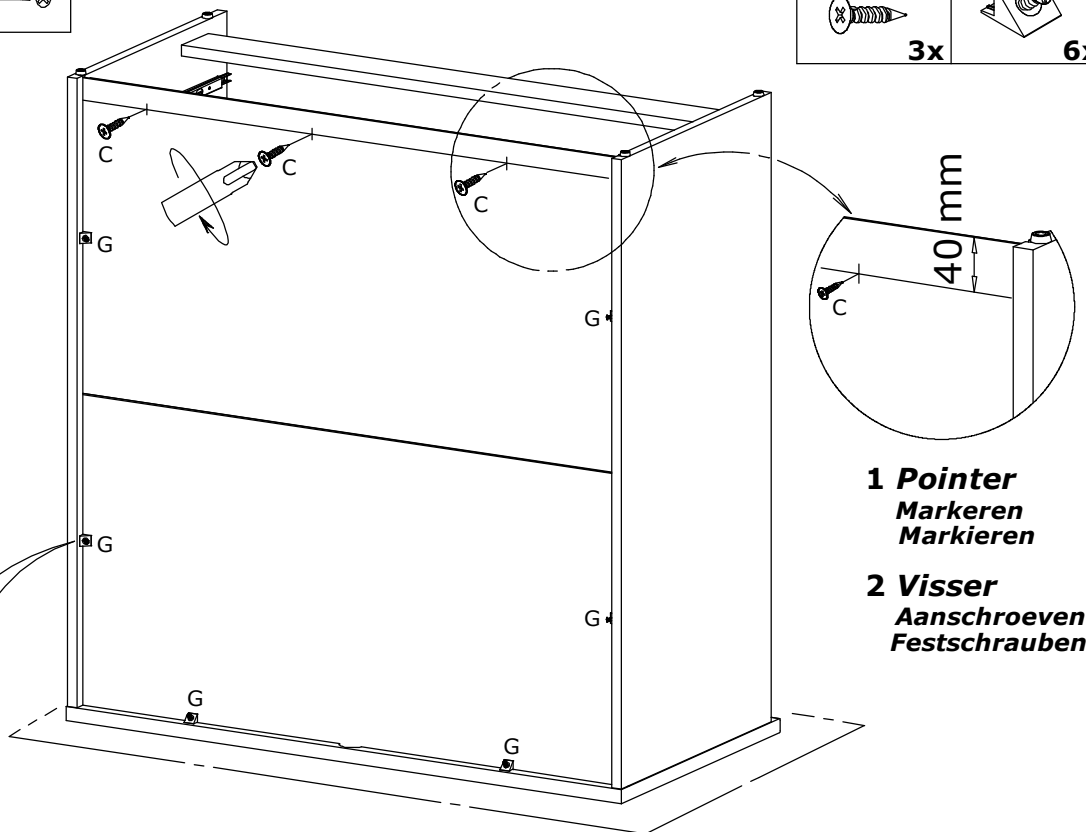
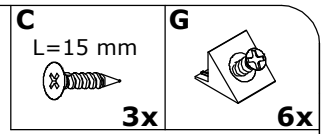
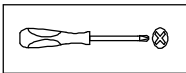

- 1 Pointer
Markeren
Markieren**
- 2 Visser
Aanschroeven
Festschrauben**

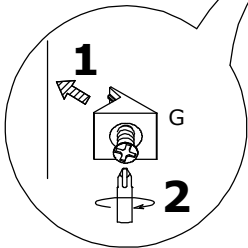

12

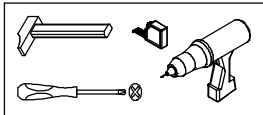

Fixation murale Bevestigen aan de muur Wandfixierung

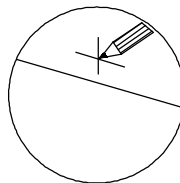
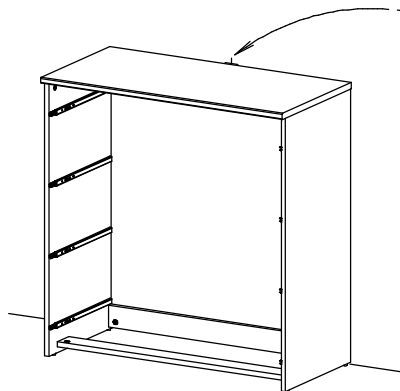
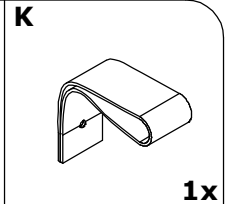
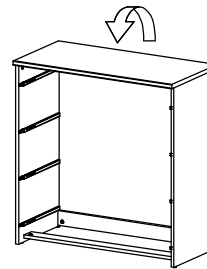

1

Tracer
Een lijn trekken
Anzeichnen

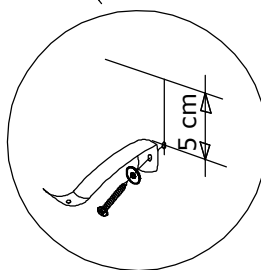
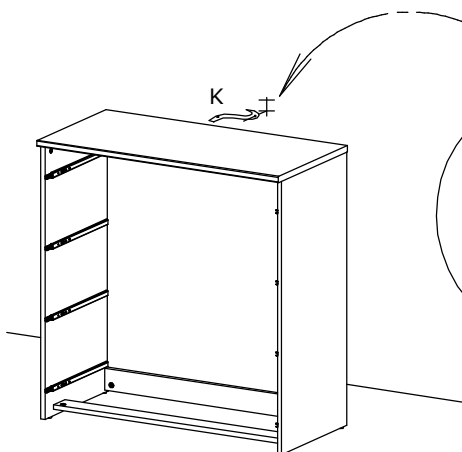

2

Fixer au mur
5 cm en dessous du traçage

5cm onder de lijn aan muur
bevestigen

An der Wand fixieren
5 cm unterhalb der Markierung

ATTENTION ! ATTENTIE ! ACHTUNG !

Cheville et vis de fixation murale **NON FOURNIES**.
Plug en schroeven zijn **NIET VERSTREKT**.
Schrauben und Dübel zur Wandfixierung **NICHT INBEGRIFFEN**.

*Vous devez les choisir en fonction de votre mur.
Deze moet u naargelang uw muur zelf kiezen.
Diese sind je nach Wandbeschaffenheit auszuwählen.*

*Si besoin adressez-vous à un magasin spécialisé.
Indien nodig kunt u zich wenden tot een speciale winkel.
Bei Bedarf wenden Sie sich an ein Fachgeschäft.*

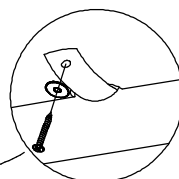
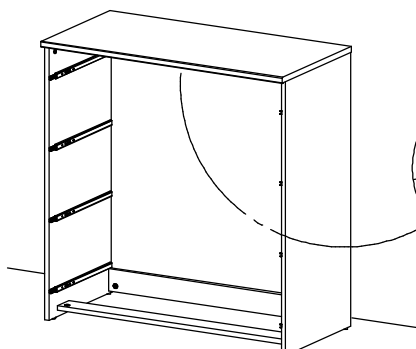

3

Fixer au meuble
Aan het meubel vastmaken
An den Möbel festschrauben

French

IMPORTANT : Pour éviter le basculement accidentel du meuble, la fixation du meuble au mur est obligatoire.
La visserie nécessaire pour la jonction mur/meuble, dépendante de la nature du mur, n'est pas fournie.
En cas de doute, consulter un spécialiste.

English

IMPORTANT : To avoid the accidental tip-over of the furniture, the fixing of the furniture on the wall is mandatory.
The needed hardware for the junction wall/furniture, depending of the nature of the wall, is not provided.
If any doubt, consult a specialist.

Spanish

IMPORTANTE : Para evitar el vuelco accidental de los muebles, es obligatorio fijarlos en la pared.
El tipo de tornillos necesarios para fijar el mueble a la pared, dependen del material de la pared, no se suministran.
En caso de duda, consulte a un especialista.

Portuguese

IMPORTANTE : Para evitar a queda accidental de moveis, é obrigatorio fixa-los na parede.
O tipo de parafusos para a fixação de mobiliario na parede, depende do material de parede e não são fornecidos.
Em caso de duvida, consulte um especialista.

Italian

IMPORTANTE : Per evitare il ribaltamento accidentale del mobile è obbligatorio il fissaggio a muro.
I tasselli necessari per il collegamento mobile/muro, dipendenti dal tipo di muro, non sono provvisti.
Consultare uno specialista in caso di dubbi.

Croatian

VAZNO : Kako biste izbjegli mogućnost prevrtanja, namjestaj se mora pricvrstiti na zid odgovarajućom vrstom vijaka.
Različite vrste zidova zahtijevaju različite vrste vijaka. Koristite onu vrstu vijaka koja odgovara vrsti u vašem domu. Ukoliko niste sigurni koju vrstu vijaka ili okova upotrijebiti, kontaktirajte prodavaonicu za okove. Uz ovaj proizvod, vijci za pricvrscivanje u zid nisu uključeni.

Serbian

VAZNO : Kako biste izbjegli mogućnost prevrtanja, nameštaj mora da se pricvrsti na zid odgovarajućom vrstom vijaka. Različite vrste zidova zahtevaju različite vrste vijaka. Koristite onu vrstu vijaka koji odgovaraju vrsti zida u savem domu. Ako niste sigurni koju vrstu vijaka treba da koristite, kontaktirajte prodavnicu za srafovsku robu. Uz ovaj proizvod, vijci za pricvrscenje u zid nisu uključeni.

German

WICHTIG : Um ein versehentliches Kippen des Möbels zu vermeiden, ist die Befestigung an der Wand zwingend vorgeschrieben.
Die benötigten Schrauben zur Wandbefestigung, welche von der Beschaffenheit der Mauer abhängen, sind nicht in der Lieferung enthalten.
Wenden Sie sich bitte bei Zweifel an einen Spezialisten.

Netherlandish

BELANGRIJK : Om te verhinderen dat het meubelstuk omkiept, moet dit aan de muur bevestigd worden. Het hiertoe benodigde gereedschap wordt niet verstrekt, daar dit afhangt van de structuur van de muur. Mocht u vragen hebben, wendt u zich dan tot de vakman.

13

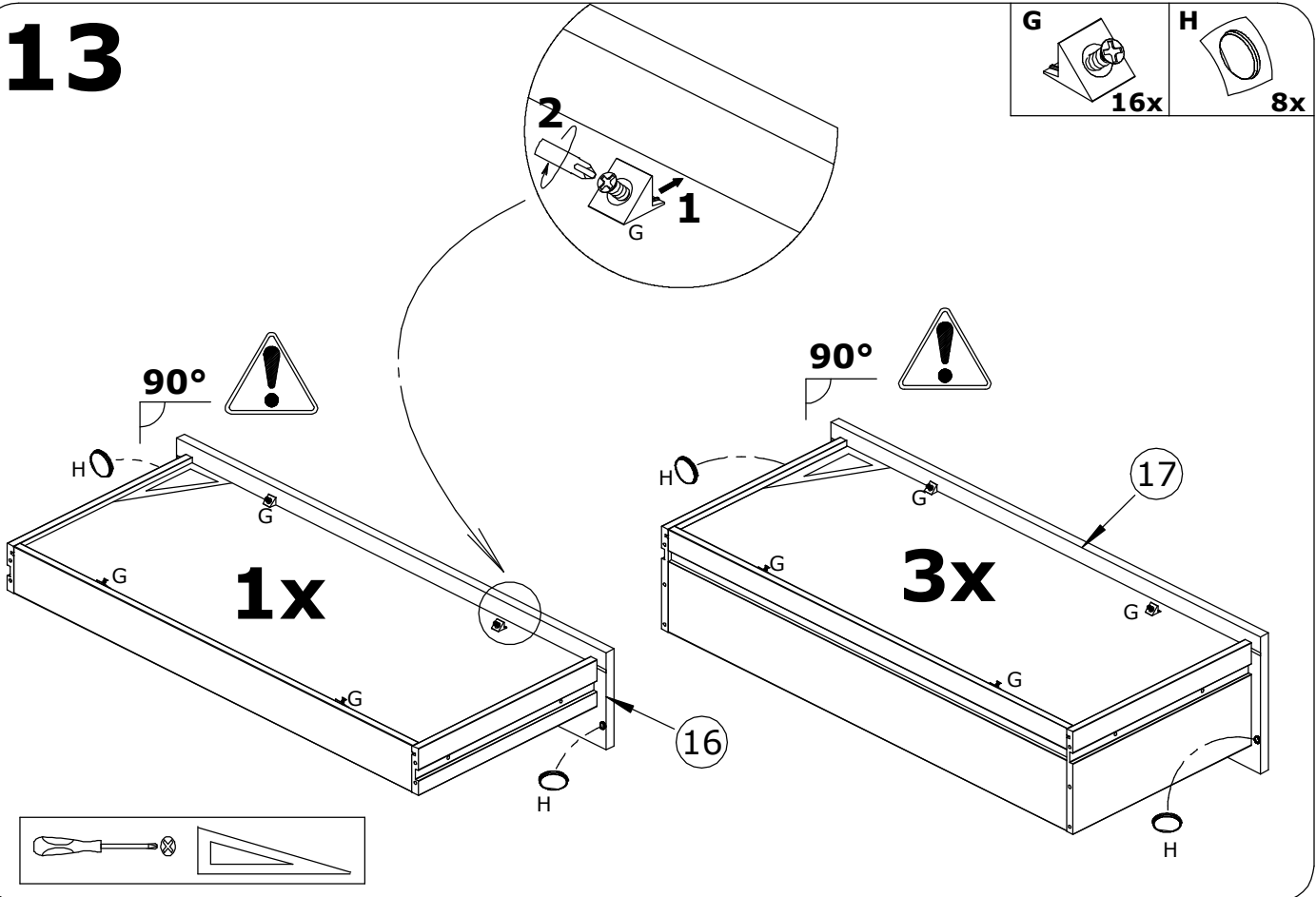
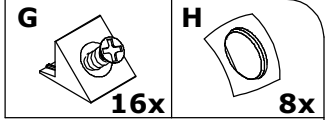

14

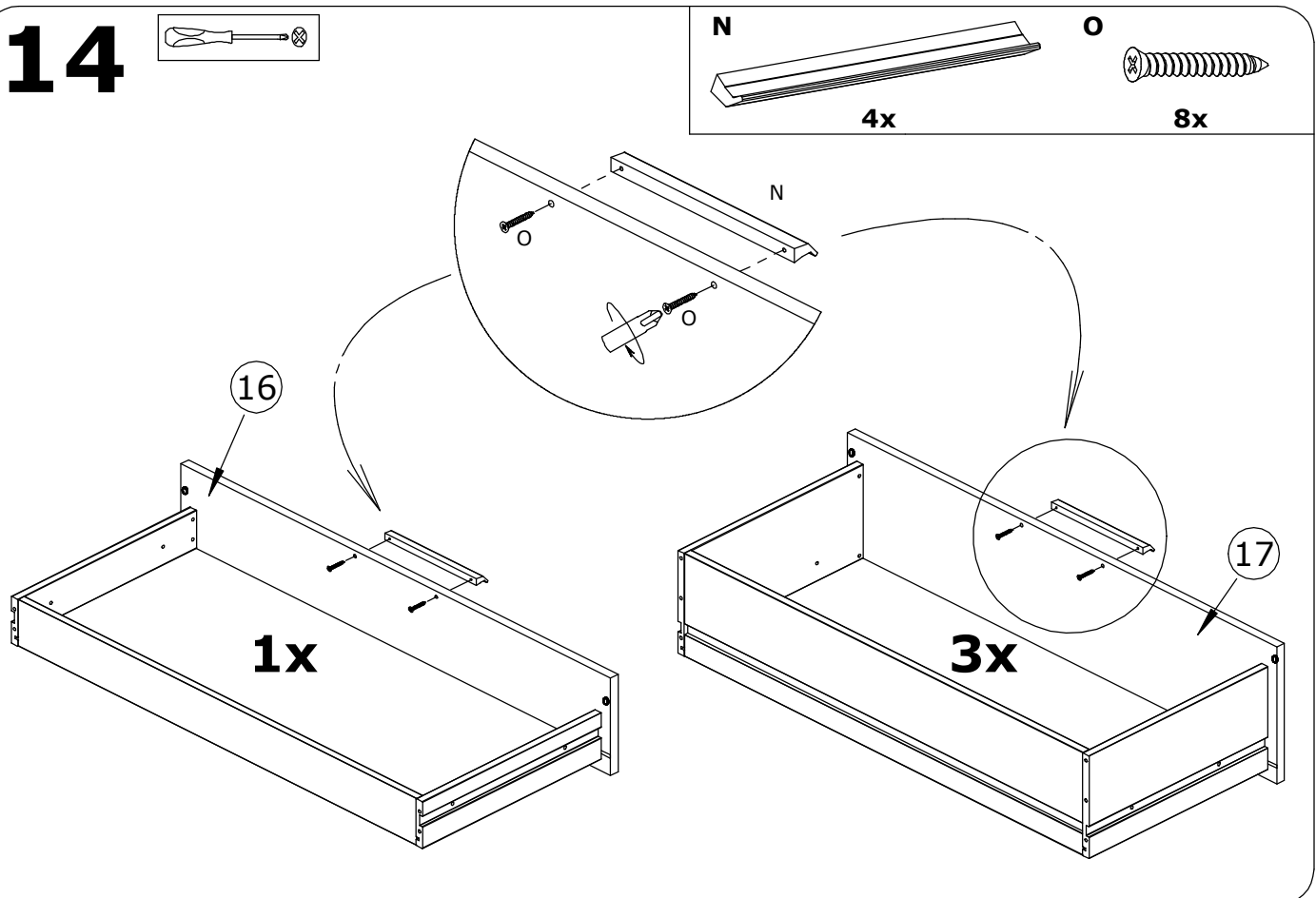
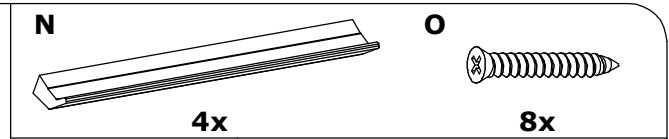
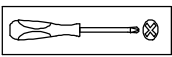

15

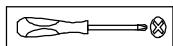

D L=9 mm



8x

16

17

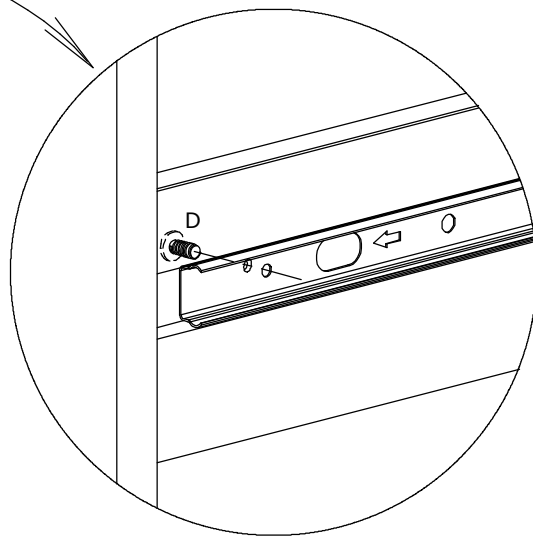
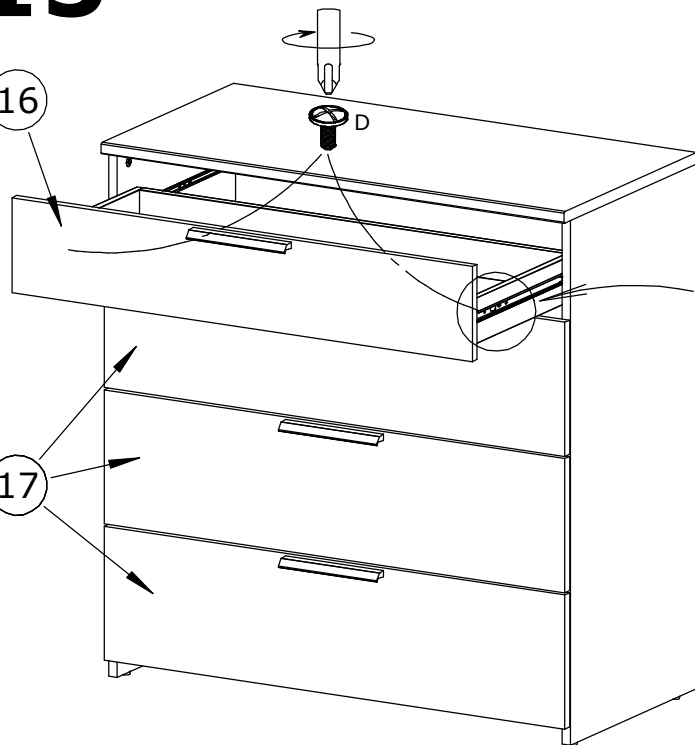

16

90°

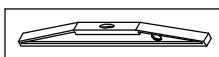

L

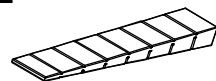

2x

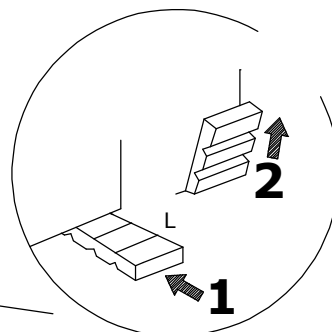
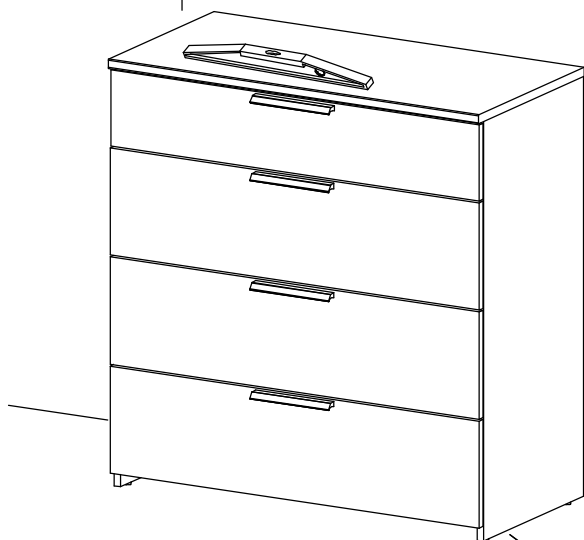

F CONSEILS D'ENTRETIEN :

- 1) Dépoussiérez soigneusement.
- 2) Humectez un chiffon doux et propre, d'eau légèrement savonneuse.
Ne jamais utiliser de produits abrasifs : poudre, laine d'acier, solvants.
Ne pas mouiller copieusement.

**NE JAMAIS FORCER LES ASSEMBLAGES
RESSERRER LES VIS APRES QUELQUES TEMPS D'USAGE
GARDER VOTRE NOTICE DE MONTAGE, SI UNE PIECE
VENAIT A MANQUER, ELLE SERAIT LE PLUS CLAIR MOYEN
DE COMMUNIQUER AVEC VOTRE MAGASIN.**

**GB NOTICE FOR MAINTENANCE :**

- 1) Dust off carefully.
- 2) Use a soft, proper and humid duster and light soap solution to clean the furniture.
Please do not use any scouring agent like powder, steel wool, solvents.
Do not wet too much.

**NEVER FORCE THE CONNECTIONS
RE-TIGHTEN THE SCREWS AFTER FEW DAYS.
PLEASE RETAIN THE AI LEAFLET FOR FUTURE REFERENCE,
THE AI CONTAINS INFORMATION WHEN CLAIMING
FOR MISSING PARTS.**

**D PFLEGEHINWEISE :**

- 1) Sorgfältig entstauben.
- 2) Mit einem weichen, sauberen und feuchten Tuch und leichter Seifenlauge reinigen.
Benutzen Sie keine Scheuermittel wie Pulver, Stahlwolle, Lösungsmittel.
Nicht zu nass abwischen.

**NIEMALS DIE VERBINDUNGEN ZU STARCK ANZIEHEN
DIE SCHRAUBEN NACH EINIGER ZEIT DES GEBRAUCHS
ERNEUT FESTZIEHEN. DIE MONTAGEANLEITUNG GUT
AUFBEWAHREN, SOLLTE EIN TEIL FEHLEN, IST SIE DAS
BESTE VERSTÄNDIGUNGSMITTEL MIT IHREM GESCHÄFT.**

**I CONSIGLI PER LA MANUTENZIONE :**

- 1) Spolverate accuratamente.
- 2) Inumidire con acqua leggermente insaponata uno straccio morbido e pulito.
Non utilizzare mai prodotti abrasivi : polvere, lana di acciaio, solventi.
Non bagnare troppo.

**NON FORZARE MAI GLI ASSEMBLAGGI
RISTRINGERE LE VITI DOPO UN PERIODO D'USO
CONSERVARE QUESTE ISTRUZIONI DI MONTAGGIO, SE
UN PEZZO VENISSE A MANCARE SAREBBE IL MIGLIORE
MEZZO DI COMUNICAZIONE CON IL RIVENDITORE.**

**E RECOMENDACIONES PARA EL MANTENIMIENTO :**

- 1) Despolvorear cuidadosamente.
- 2) Humedecer un pano suave y limpio con agua ligeramente enjabonada.
No use nunca productos abrasivos tales como : polvo de limpiar, lana de acero, solventes.
No mojar exageradamente.

**NO FUERCE NUNCA EN LAS UNIONES . APRIETE LOS
TORNILLOS DESPUES DE CIERTO TIEMPO DE UTILIZACION
CONSERVE SU MANUAL DE MONTAJE, SI FALTARA UNA
PIEZA, SERIA LA MANERA MAS FACIL DE COMUNICAR
CON LA TIENDA.**

**P NORMAS DE MANUTENCAO :**

- 1) Eliminar bem o po.
- 2) Umedecer um pano suave e limpo com agua e um pouco de sabao.
Nunca utilizar produtos abrasivos : pos, la de aço, solventes.
Nao molhar demasiado.

**NUNCA FORCAR OS ENCAIXES.REAPERTAR OS
PARAFUSOS APOS UM TEMPO DE UTILIZACAO.
GUARDAR AS INSTRUCOES DE MONTAGEM.
CASO FALTE ALGUMA PECA , O MAIS A CONSELHABEL
E CONTATAR O REVENDEDOR.**

**TR BAKIM TALIMATLARI :**

- 1) Tozunu dikkatlice aliniz.
- 2) Yumusak bir bezi temiz su ve az miktarda sabunla (deterjan) nemiendiriniz
- Asla asindirici ürünler kullanmayiniz : Celik yünü, solvent
- Bol suyla yikamayiniz.

**MONTAJLARI ZORLAMAYINIZ.
BIRKAC KULLANIMDAN SONRA VIDALARI SIKISTIRINIZ.
BIR PARCANIN KAYBOLMASI DURUMUNDA MAGAZANIZ-
LADAH KOLAY ILETISIME GECEBILMENIZ ICIN MONTAJ
KULLANIM TALIMATINIZI SAKLAYINIZ.**

**HR UPUTE ZA ODRZAVANJE :**

- 1) Pazljivo obrisati prasinu.
- 2) Koristite suhu krpu.
- Zabranjena je upotreba kemikalija ili bilo kakvih pomocnih sredstava za ribanje jakih sredstava za ciscenje ili celigne vune
- Ne mokra.

**NEMOJTE UPOTREBLJAVATI SILU PRILIKOM SKLAPANJA
NAKON NEKOG VREMENA PONOVRNO PRITEGNITE VIJKE
CUVAJTE UPUTE ZA MONTAZU
U SLUCAJU NEDOSTATKA NEKOG DIJELA NAJBOJE CE BITI
DA KONTAKIRATE PRODAJNO MJESTO.**

**NL VEILIGHEIDS MAATREGELEN**

- 1) Poets voorzichtig.
- 2) Nooit poetsen met veel water of met schurende producten. Gebruik alleen een klamvochtige doek.

**LET OP ! NOOIT PROBEREN TE FORCEREN TIJDENS
DE MONTAGE VAN UW MEUBILAIR. MOCHT ER IETS
ONTBREKEN NEEM DAN DE MONTAGEHANDLEIDING
MEE NAAR UW VERKOOPPUNT.**

